

Expanding Stem Casters

1-1/4" Stem Work Table Caster with Hard Rubber Wheel

Certifications:



Features:

- Fits Standard 1-1/4" Tubing by Expanding the Stem Creating a Secure Fit
- Double Ball Bearing Raceway for Long Wear and Added Strength
- With or Without Top Lock Brake
- Raceway Dust Cover

Material:

- High Impact Molded Rubber
- Temperature Range -40° to 160°F
- Nylon Bearing Sleeve
- Hard Rubber Wheel



Part Number	Wheel Size	Exposed Height	Brake	Capacity
3SBR-2RA-HR	3" Wheel	4.125"	-	300 LBS
3SBR-2RA-HR-TLB	3" Wheel	4.125"	TLB	300 LBS
4SBR-2RA-HR	4" Wheel	5"	-	300 LBS
4SBR-2RA-HR-TLB	4" Wheel	5"	TLB	300 LBS
5SBR-2RA-HR	5" Wheel	6"	-	300 LBS
5SBR-2RA-HR-TLB	5" Wheel	6"	TLB	300 LBS

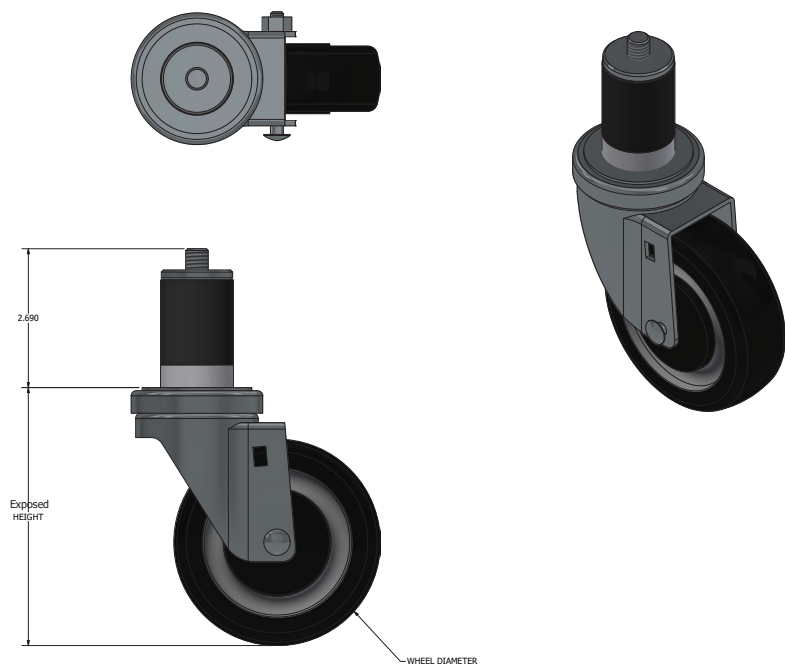

PRODUCT DATA SHEET

RESOURCES

