



ADA Compliant

This Space for Architect/Engineer Approval

Job Name _____ Date _____

Model Specified _____ Quantity _____

Customer/Wholesaler _____

Contractor _____

Architect/Engineer _____

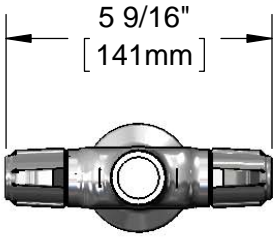

Swivel Outlet Accepts equip Swing Nozzles. Rigid Conversion Requires 014200-45 Lock Washer (Sold Separately)

Ceramic Cartridges & equip Lever Handles w/ Color Coded Screws

1 1/4" [32mm] Maximum Thickness

Mounting Surface

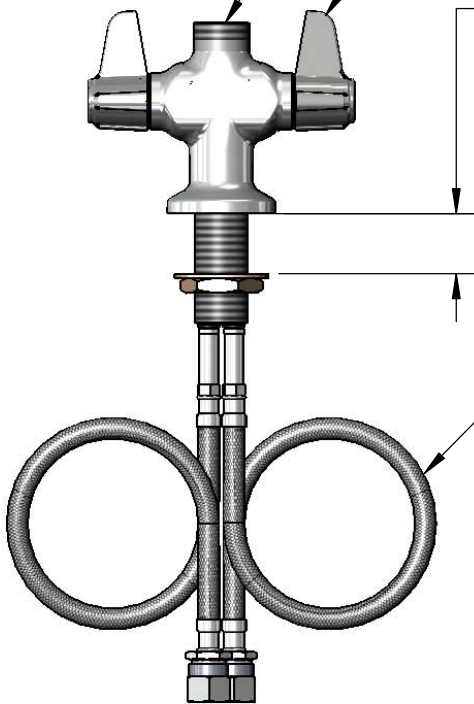

18" Long Flexible Stainless Steel Supply Hoses

Ø 1 1/8" [29mm] Shank

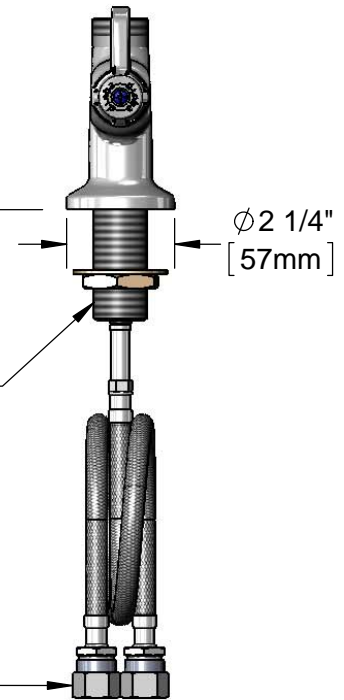

Compression Fittings for 5/8" O.D. Copper Tubing (Remove Compression Nut for 1/2" NPSM Male)

Rough-In Requirement:
Ø 1 1/2" [38mm] Mounting Hole

Model Number
5F-2SLX00

Product Specifications:
Single Hole Deck Mount Mixing Faucet, Less Nozzle, Ceramic Cartridges, equip Lever Handles & 18" Flexible Inlets

Product Compliance:
ASME A112.18.1 / CSA B125.1
NSF 61 - Section 9
NSF 372 (Low Lead Content)
ANSI A117.1 (ADA)

equip
Foodservice
Accessories

by

2 Saddleback Cove, P.O. Box 1088
Travelers Rest, South Carolina 29690
Phone: 800.891.4808 Fax: 800.868.0084
equip.tsbrass.com

ITEM NO.	SALES NO.	DESCRIPTION
1	013788-45	equip Ceramic Cartridge, LTC
2	5-HDL-L	equip Lever Handle w/ Color Coded Screws
3	002290-45	Lock Washer
4	000965-45	Lock Nut
5	012534-45	18" Flexible Supply Hose (2)
6	013787-45	equip Ceramic Cartridge, RTC

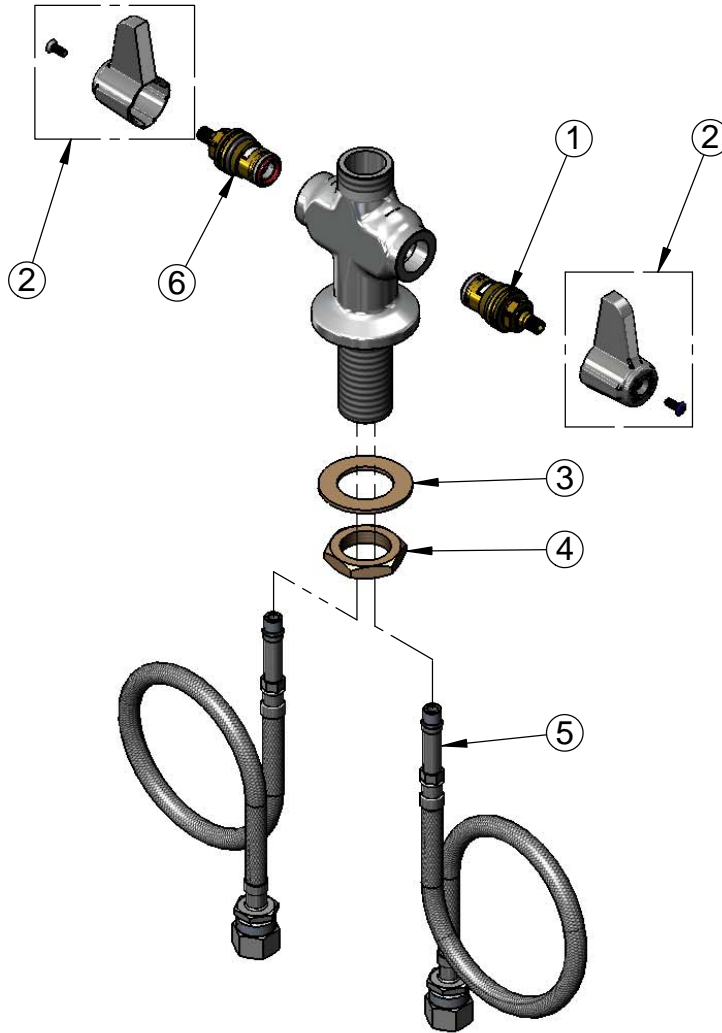

Model Number

5F-2SLX00

Product Specifications:

Single Hole Deck Mount Mixing Faucet, Less Nozzle, Ceramic Cartridges, equip Lever Handles & 18" Flexible Inlets

Product Compliance:

ASME A112.18.1 / CSA B125.1
 NSF 61 - Section 9
 NSF 372 (Low Lead Content)
 ANSI A117.1 (ADA)

equip
 Foodservice
 Accessories

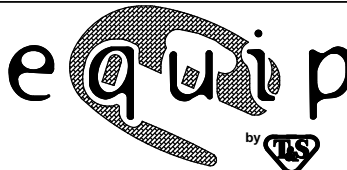

2 Saddleback Cove, P.O. Box 1088
 Travelers Rest, South Carolina 29690
 Phone: 800.891.4808 Fax: 800.868.0084
 equip.tsbrass.com