

## "GS6-SSK" EQUIPMENT STANDS

### *16GA Stainless Steel Top w/Stainless Steel Base & Shelf*

#### FEATURES:

- 16GA Type 300 Stainless Steel Top With #4 Polish, Satin Finish
- 1-1/2" Stallion Edge On Front. Turned Up Back And Both Sides
- Top Frame Is Reinforced By A Full Frame Fabricated Of 1-1/2" Square O.D. Tube 16GA Stainless Steel
- Stainless Steel Base
- Shipped Knocked-Down, Easy-To-Assemble (Welded Setup Available)

#### SPECIFICATIONS:

- Top: Stainless Steel Tops Are TIG Welded, Exposed Welds Are Polished To Match Adjacent Surface
- Top: 16GA Stainless Steel Type 300 Stainless Steel With #4 Polish, Satin Finish
- Shelf: 18GA Stainless Steel
- Legs: 1-5/8" Round O.D. 16GA Tubular Stainless Steel
- Gussets: Stainless Steel
- Feet: 1" Adjustable Stainless Bullet Feet



GS6-3048SSK

#### CERTIFICATIONS:



## "GS6-SSK" EQUIPMENT STANDS

LENGTH	24" WIDE	WT. (LBS)	30" WIDE	WT. (LBS)	36" WIDE	WT. (LBS)
15"	GS6-2415SSK	25	GS6-3015SSK	36	GS6-3615SSK	45
18"	GS6-2418SSK	30	GS6-3018SSK	40	GS6-3618SSK	50
24"	GS6-2424SSK	45	GS6-3024SSK	51	GS6-3624SSK	65
30"	GS6-2430SSK	60	GS6-3030SSK	63	GS6-3630SSK	80
36"	GS6-2436SSK	65	GS6-3036SSK	69	GS6-3636SSK	90
48"	GS6-2448SSK	80	GS6-3048SSK	90	GS6-3648SSK	100
60"	GS6-2460SSK	95	GS6-3060SSK	111	GS6-3660SSK	127
72"	GS6-2472SSK *	111	GS6-3072SSK *	132	GS6-3672SSK *	154

**\*NOTE: HAS 3 SETS OF LEGS**

ALL DIMENSIONS ARE TYPICAL. TOLERANCE +/- .500". JOHN BOOS & CO. RESERVES THE RIGHT TO CHANGE SPECIFICATIONS WITHOUT NOTICE.

# DETAILED SPECIFICATIONS

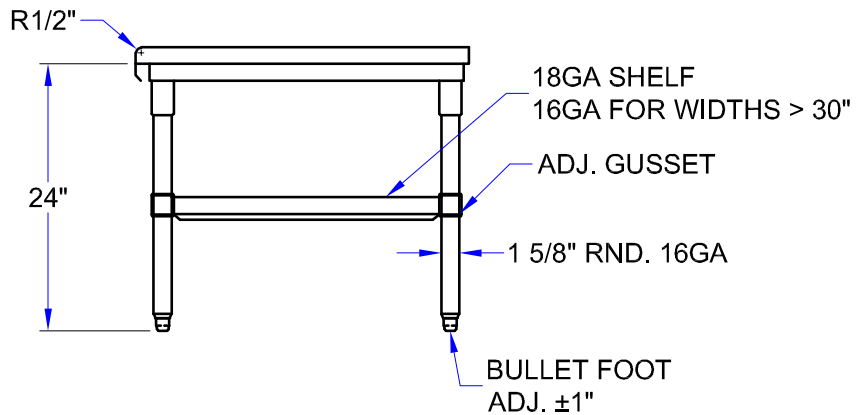
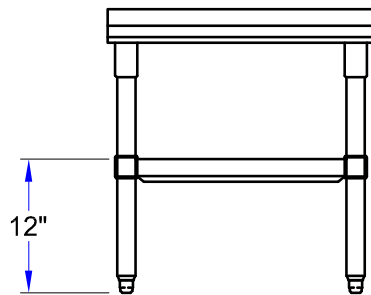
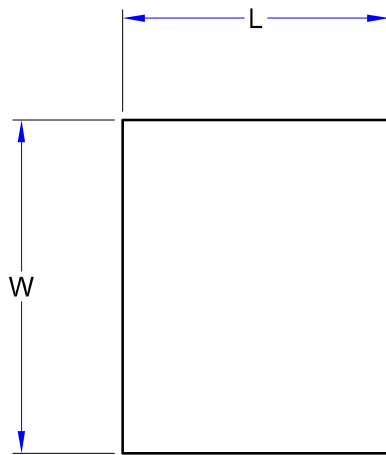

## "GS6-GBK" EQUIPMENT STANDS

LENGTH	24" WIDE	WT. (LBS)	30" WIDE	WT. (LBS)	36" WIDE	WT. (LBS)
15"	GS6-2415SSK	25	GS6-3015SSK	36	GS6-3615SSK	45
18"	GS6-2418SSK	30	GS6-3018SSK	40	GS6-3618SSK	50
24"	GS6-2424SSK	45	GS6-3024SSK	51	GS6-3624SSK	65
30"	GS6-2430SSK	60	GS6-3030SSK	63	GS6-3630SSK	80
36"	GS6-2436SSK	65	GS6-3036SSK	69	GS6-3636SSK	90
48"	GS6-2448SSK	80	GS6-3048SSK	90	GS6-3648SSK	100
60"	GS6-2460SSK	95	GS6-3060SSK	111	GS6-3660SSK	127
72"	GS6-2472SSK *	111	GS6-3072SSK *	132	GS6-3672SSK *	154

\*NOTE: HAS 3 SETS OF LEGS

ALL DIMENSIONS ARE TYPICAL. TOLERANCE +/- .500". JOHN BOOS & CO. RESERVES THE RIGHT TO CHANGE SPECIFICATIONS WITHOUT NOTICE.