



Project _____
 AIA # _____ SIS # _____
 Item # _____ Quantity _____ C.S.I. Section 114000

G-SERIES

2-Section Refrigerator Reach-In Self-Contained Solid Door(s)



STANDARD PRODUCT FEATURES

- High Performance, Energy Efficient Refrigeration System Using R-290
- Reliable Microprocessor Control With LED Temperature Display
- Evaporator Coil Outside Food Zone Provides More Usable Space
- Load-Sure Guard Prevents Problems From Improper Loading
- Durable All-Metal Construction
- Stainless Steel Front & Doors, Anodized Aluminum Sides & Interior
- Full or Half Height Door Models with a Variety of Hinging Configurations
- Long Life EZ-Clean Door Gaskets
- Three (3) Epoxy Coated Shelves Per Section (factory installed)
- Easy to Maintain Front Facing Condenser Coil
- 6" High Locking Casters

FIELD INSTALLED ACCESSORIES & OPTIONS

- Trayslides for 18" x 26" Sheet Pans
- Trayslides for 12" x 20" Food Pans
- Trayslides for 14" x 18" Sheet Pans
- Trayslides for 18" x 26", 12" x 20" & 14" x 18" Pans
- Additional Shelves
- Set of (4) 4 1/8" Casters in Lieu of Standard
- 6" High Legs



This unit is listed to the applicable ETL and NSF Standards by an approved NRTL. Consult the factory or unit's data plate for approval information.

AVAILABLE CONFIGURATIONS

Half-Height Door Models

G20000
 G20001
 G20002
 G20003

Hinging

Left/Right
 Right/Left
 Right/Right
 Left/Left

Full-Height Door Models

G20010
 G20011
 G20012
 G20013

Hinging

Left/Right
 Right/Left
 Right/Right
 Left/Left

***Please refer to the G-Series Accessory Kit Guide for precise details. (Form TR35872)**

-GUARANTEED FOR LIFE CAM-LIFT HINGES

-GUARANTEED FOR LIFE HORIZONTAL WORKFLOW DOOR HANDLES (SOLID DOORS ONLY)



ENERGY STAR® Listed Commercial Refrigerator
 For full listing visit energystar.gov

Approved by _____ Date _____ Approved by _____ Date _____

MODELS:

Half Height Door Models: G20000, G20001, G20002, G20003

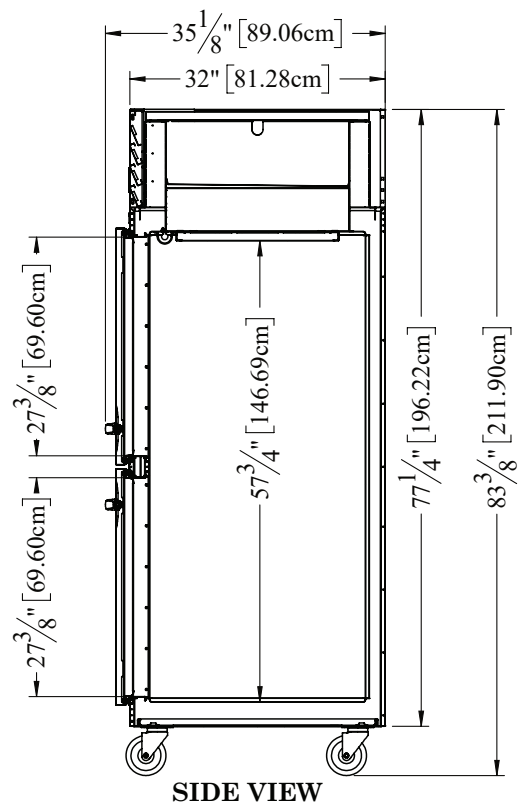
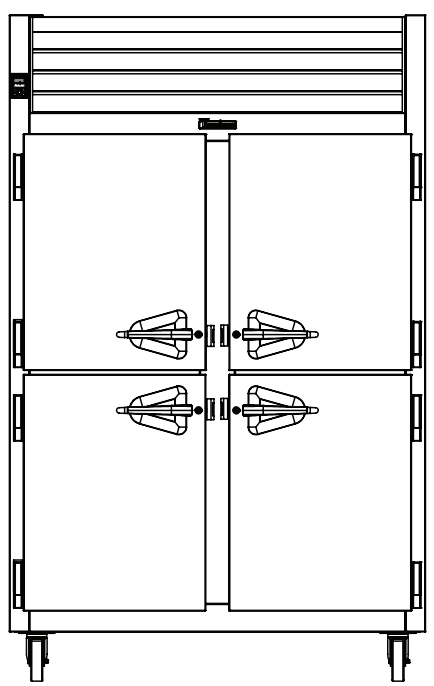
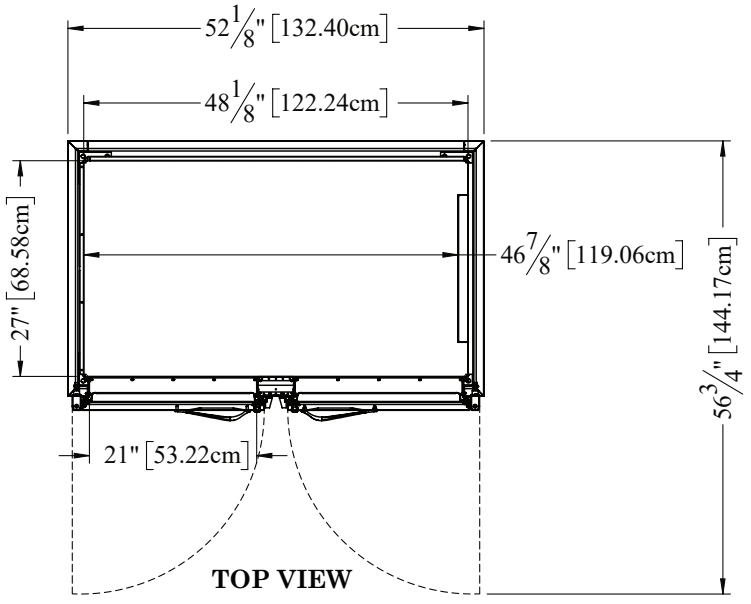

G-SERIES

2-Section Refrigerator Reach-In Self-Contained Solid Door(s)

MODELS:

Full Height Door Models: G20010, G20011, G20012, G20013

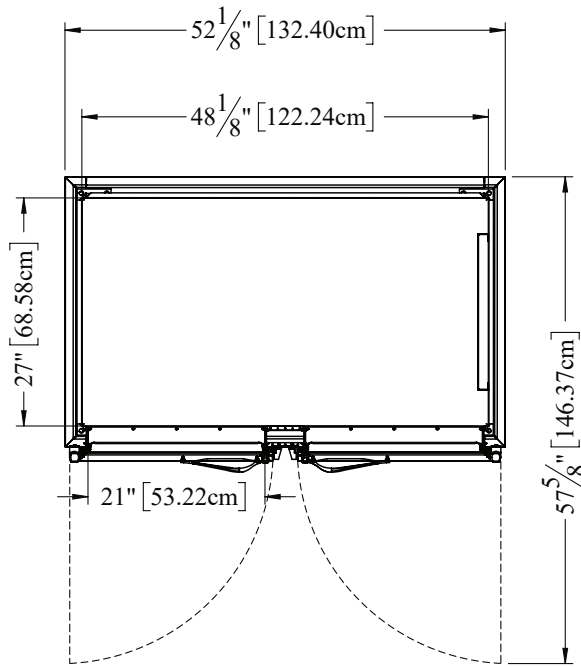

TOP VIEW

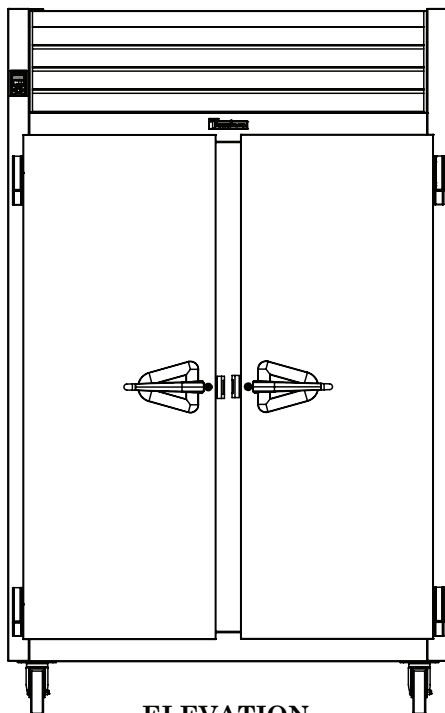

ELEVATION

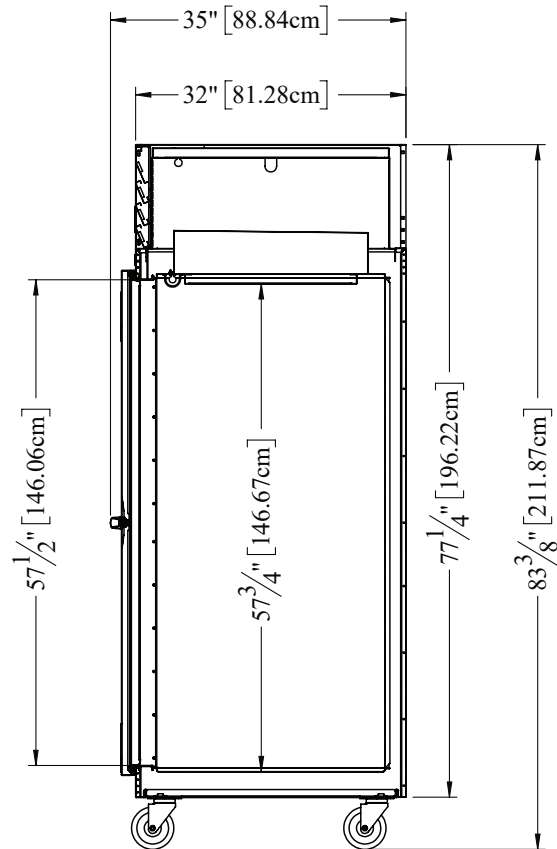

SIDE VIEW



G-SERIES

2-Section Refrigerator Reach-In Self-Contained Solid Door(s)

MODELS:

Half Height Door Models: G20000, G20001, G20002, G20003

Full Height Door Models: G20010, G20011, G20012, G20013

EQUIPMENT SPECIFICATIONS

MODELS	G200__
DIMENSIONAL DATA	
Net Capacity cu. ft. ¹	45.89 (1300 l) 46.02 (1303 l)
Length - overall in.	52 ⁷ / ₈ " (132.4 cm)
Depth - overall in.	35" (88.8 cm)
Depth - over body in.	32" (81.3 cm)
Depth - door open 90° in.	57 ⁵ / ₈ " (146.3 cm)
Clear door width in.	21" (53.2 cm)
Clear half-door height in.	27 ³ / ₈ " (69.6 cm)
Clear full-door height in.	57 ¹ / ₂ " (146.1 cm)
Height - overall on 6" legs in. ²	83 ³ / ₈ " (211.9 cm)
No. Standard Shelves	6
Shelf Area sq. ft. ³	34.6 (3.21 sq m)
ELECTRICAL DATA	
Voltage Plug	115/60/1 NEMA 5-15P (attached)
Feed wires with ground	3
Full Load Amperes KWH/24HR ⁴	4.3 2.74
REFRIGERATION DATA	
Refrigerant	R-290
Refrigerant Charge oz.	4.5 (127.6 g)
BTU/HR H.P. ⁵	2100 1/4 HP
SHIPPING DATA	
Length - Crated in.	62" (158 cm)
Width - Crated in.	42" (107 cm)
Height - Crated in.	85" (216 cm)
Volume - Crated cu. ft.	128 (3625 l)
Weight - Crated lbs.	480 (218 kg)

CONSTRUCTION, HARDWARE, INSULATION

Cabinet exterior front, louver assembly and door(s) are constructed of heavy gauge stainless steel. Cabinet sides (including returns), interior and door liners are constructed of anodized aluminum. The exterior cabinet top, back and bottom are constructed of heavy gauge galvanized steel. A set of four (4) 6" high locking casters are included.

Doors are equipped with a gasket protecting, raised metal door pan, cylinder locks, and guaranteed for life self-closing cam-lift hinges with a stay open feature at 120 degrees. Hinges include a concealed switch to automatically activate the interior LED lighting. Guaranteed for life, metal work flow door handles are mounted horizontally over recess in door which limits protrusion into aisle ways.

Gasket profile and durable long life material simplify cleaning and increase overall gasket life. Anti-condensate heaters are located behind each door opening.

Both the cabinet and door(s) are insulated with an average of 2" thick high density, non-CFC, 100% foamed in place polyurethane.

SELF-CONTAINED REFRIGERATION SYSTEM

A top mounted, self-contained, balanced refrigeration system using environmentally-friendly, low GWP R-290 refrigerant is conveniently located behind the one piece louver assembly. It features an easy to clean front facing condenser, thermostatic expansion valve metering device, air-cooled hermetic compressor, large, high humidity evaporator coil located outside the food zone and a top mounted non-electric condensate evaporator. A 9' cord and plug is provided. Standard operating temperature is 34 to 38°F.

CONTROL

The easy to use water resistant microprocessor control is supplied standard. It includes a 3-Digit LED Display, and a Fahrenheit or Celsius Temperature Scale Display Capability.

INTERIOR ARRANGEMENTS

Standard interior arrangements include three (3) epoxy coated steel wire shelves per section, mounted on shelf pins, installed at the factory. Shelves are full-width, and do not have any large gaps between them requiring the use of "bridge" or "junior shelves." Recommended load limit per shelf should not exceed 225 lbs.

DOMESTIC WARRANTY

Both a six year parts and labor warranty and an additional one year compressor parts warranty (for a total of seven on self-contained models) are provided standard.

NOTES:

1. Net Capacity cu. ft. = Half Height Door | Full Height Door models.
2. 12" Top clearance preferred for optimum performance & service access.
3. Figure shown reflects the area of standard shelf compliment.
4. KWH/24HR = Kilowatt usage per 24 hours
5. Based on a 90°F ambient and 20°F evaporator.

When ordering please specify: Voltage, Hinging, and Options.

Equipped with one NEMA 5-15P Plug



OPTIONAL ACCESSORY TRAYSLIDE VERSATILITY CHART

TRAYSLIDE DRAWINGS						
TRAYSLIDE OFFERING	#1 (1) 18" x26" or (2) 14"x18"	#4 (Rod Type) (1) 18" x26"	Universal (1) 18" x26" or (2) 14"x18" or (2) 12"x20"	#1 EZ-Change (1) 18" x26" or (2) 14"x18"	Universal EZ-Change (1) 18" x26" or (2) 14"x18" or (2) 12"x20"	HD Universal EZ-Change (1) 18" x26" or (2) 14"x18" or (2) 12"x20"
SPACING CAPACITY DOOR SIZE	2" 28 Pairs Full Door & 13 Half 3" 19 Pairs Full Door & 09 Half 4" 14 Pairs Full Door & 07 Half 5" 11 Pairs Full Door & 05 Half	1 1/2" 38 Pairs Full Door (2 Pair) 1 1/2" 18 Pairs Half Door (1 Pair)	4" 14 Pairs Full Door & 06 Half 4" 14 Pairs Full Door & 07 Half 5" 11 Pairs Full Door & 05 Half 6" 09 Pairs Full Door & 04 Half	2" 26 Pairs Full Door & 12 Half 4" 13 Pairs Full Door & 06 Half	2 1/4" 22 Pairs Full Door & 11 Half 4 1/2" 11 Pairs Full Door & 05 Half	4 1/2" 11 Pairs Full Door & 05 Half 9" 05 Pairs Full Door & 02 Half

- Upper Half Height Door¹
- Lower Half Height Door²

CONTINUED PRODUCT DEVELOPMENT MAY NECESSITATE SPECIFICATION CHANGES WITHOUT NOTICE.