



# BEVERAGE-AIR

Project: _____	AIA#
Item: _____	
Location: _____	SIS#
Approved: _____	

**DPD119HC FOOD PREPARATION : DELI/PIZZA PREP SERIES**

## FOOD PREPARATION SERIES

**MODEL:  
DPD119HC-8**

DPD119HC Deli/Pizza Prep Table with Eight Drawers  
Hydrocarbon Series



**3 Year Parts/Labor Warranty  
Additional 4 Year Compressor Warranty**

### CABINET CONSTRUCTION

- Stainless steel front, sides, top, drawers and grille (galvanized back & bottom)
- Interior liner is made of corrosion resistant aluminum
- Aluminum top interior liner prevents spill from falling into cabinet
- Stainless steel top
- Removable hoods and insulated lid assemblies are made of matching stainless steel
- Magnetic gaskets provide positive seal on drawers
- 3" Casters, 2 with brakes standard
- 19" Wide reversible cutting board is removable for easy cleaning
- Units will accept pans up to 6" deep (pans are not included)
- Drawer frames are heavy-duty stainless steel
- 12-Gauge stainless steel drawer slides with Delrin® rollers rated at 275 lbs
- Telescoping slides, with locking mechanism to prevent drawers from being pulled off of cabinet
- Heavy-duty pan locking divider supports are standard in drawers

### OPTIONS & ACCESSORIES

- Stainless steel back and grille
- Stainless steel interior
- Clear-lid models
- Combination door/drawer models
- Composite cutting board
- Night Cover
- 6" Casters
- 6" Legs black or seismic/flanged
- Remote option\* (see note on back page)

### REFRIGERATION SYSTEM

- Uses environmentally friendly, energy efficient R290 refrigerant, and meets all regulatory requirements for CARB, SNAP, DOE & more
- Adaptive defrost
- Epoxy coated evaporator coil
- Raised rail maintains temperatures between 36° - 38°F



Please verify qualifying units by visiting:  
[www.energystar.gov/cfs](http://www.energystar.gov/cfs)

3779 Champion Blvd., Winston-Salem, NC 27105  
1-888-845-9800 Fax: 1-336-245-6453  
Beverage-Air.com Sales@bevair.com



# BEVERAGE-AIR

MODEL	DPD119HC-8
<b>EXTERNAL DIMENSIONAL DATA</b>	
Width Overall	119"
Depth Overall	37"
Height Overall with Casters	53 1/8"
Number Drawers	8
Depth with Drawer Extended	56 1/4"
Drawer Opening	21 5/8" x 10 5/8"
<b>INTERNAL DIMENSIONAL DATA</b>	
NET Capacity (cubic ft.)	42.2
Internal Width Overall (in)	100"
Internal Depth Overall (in)	26"
Internal Height Usable (in)	23 3/4"
<b>ELECTRICAL DATA</b>	
Full Load Amperes	7.8
<b>REFRIGERATION DATA</b>	
Horsepower	1/2
Capacity (BTU/Hr)	4234
<b>SHIPPING DATA</b>	
Gross Weight - Crated	703 lbs
Height - Crated	47 1/2"
Width - Crated	122"
Depth - Crated	37"

\*NOTE: Remote units are field wired and come with 6" legs.  
Refrigerant must be specified at time of order.

## Deli/Pizza Preparation Table

Models: DPD119HC-8

### Model Views

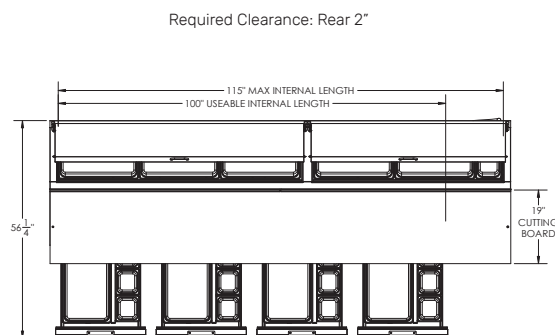

### PLAN VIEW

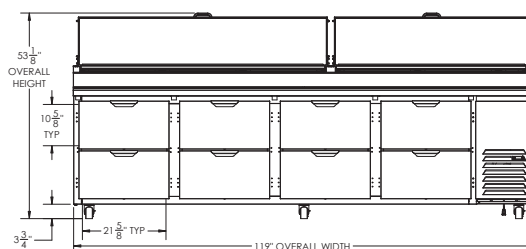

### ELEVATION VIEW

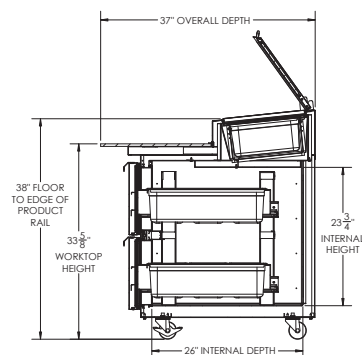

### SIDE VIEW

### \*ELECTRICAL CONNECTION



115/60/1  
NEMA 5-15P

Unit pre-wired at  
factory and include 8'  
long cord and plug set.



3779 Champion Blvd., Winston-Salem, NC 27105 1-888-845-9800 Fax: 1-336-245-6453 Beverage-Air.com Sales@bevairst.com

an Ali Group Company



The Spirit of Excellence