

# BASE MODEL REFRIGERATOR

## Model: RA93NBS

Natural Refrigerant R-290 Model

### 93" Base Worktop Refrigerator with Solid Doors and 5½" Backsplash



ENERGY STAR® Qualified Commercial Refrigerator

Heavy gauge #300 Series stainless steel top, stainless steel front and end panels, galvanized steel rear and grill and aluminum interior.



## Options and Accessories

(upcharge and lead times may apply)

Stainless steel interior	Different size casters
Stainless steel back	Adjustable legs
Additional epoxy coated steel shelves	Door locks
Stainless steel shelves	Front breathing
Overshelves (single or double)	Compressor left (standard on right)
Pan slides	Drawers in lieu of doors**
Drawer in lieu of door section above the condensing unit*	

Consult factory for other model configurations, options and accessories.

\*Drawer section above condensing unit holds (1) 12 x 20 x 6 pan.

\*\*Two tier (larger section): (2) 12x20x6 pans per drawer

**Continental**  
Refrigerator



Project Name:

Model Specified:

Location:

Item No:

Quantity:

AIA #:

SIS #:

## Standard Model Features

### REFRIGERATION SYSTEM

Performance rated refrigeration system

Natural, environmentally safe, high efficiency R-290 refrigerant<sup>1</sup>

Unique forced air design utilizes fans (approx. every 12") across the entire back of unit for even distribution of cold

Automatic, hot gas condensate evaporator

Non-corrosive, plasticized fin evaporator coil

Easily serviceable, slide out condensing unit

Expansion valve system

### CABINET ARCHITECTURE

2" non-CFC polyurethane foam insulation

Smooth, polished chrome door handles

Spring loaded, self closing doors

Magnetic snap in Santoprene™ door gaskets

Heavy duty, epoxy coated steel shelves

Completely enclosed, vented and removable rear and side grills

5" casters

### MODEL FEATURES

Electronic control, off cycle defrost

Reversing condenser fan motor (runs for short period during startup to clear any debris)

Refrigerated section with door above the condensing unit

Field rehingeable doors

<sup>1</sup> R-290 refrigerant meets all federal and state regulatory requirements.

**NOTE:** Models come standard with a door over the condensing unit. A drawer over the condensing unit is an option.

APPROVAL:

# Model Specifications

## DIMENSIONAL DATA

Net Capacity (cubic feet)	32 (906 l)
Width, Overall (inches)	93 (2362 mm)
Depth, Overall (inches) (including handles & bumpers)	37 (939 mm)
Height, Overall (inches) (including 5" casters)	40 1/2 (1029 mm)
Shelf Area (square feet)	14.2 (1.3 sq m)
Number of Shelves	6
Number of Full Doors	3
Number of Half Doors	1
Interior Depth (inches)	30 (762 mm)
Interior Height (inches)	26 (660 mm)
Interior Height (inches) (above condenser)	12 1/2 (318 mm)
Interior Width (inches)	89 (2261 mm)

## REFRIGERANT DATA

Condensing Unit Size (H.P.)	1/4
R-290 Refrigerant Charge (oz)	3.6
Capacity (BTU per hour)*	1930

## ELECTRICAL DATA

Voltage (International)	115/60/1 (220/50/1)
Total Amps (International)	3.1 (1.6)
10 ft. Cord/Plug [attached] (International)	Yes (No)

## SHIPPING DATA

Weight (pounds)	520 (236 kg)
Height - Crated (inches)	45 (1111 mm)
Width - Crated (inches)	96 (2413 mm)
Depth - Crated (inches)	39 (1194 mm)

\* Rating @ +25°F evaporator, 90°F ambient  
 Figures in parentheses reflect metric equivalents rounded to the nearest whole unit.



Equipped with one NEMA-5-15P Plug  
(varies by country)

# Continental®

Refrigerator

Toll-Free: 800-523-7138  
 Phone: 215-244-1400  
 Fax: 215-244-9579

539 Dunksferry Road  
 Bensalem, PA 19020  
[www.continentalrefrigerator.com](http://www.continentalrefrigerator.com)

Due to our continued efforts in developing innovative products, specifications subject to change without notice.



PROUDLY  
 DESIGNED & ASSEMBLED  
 IN THE U.S.A.

© Copyright 2024. Continental Refrigerator.

# Model Plan Views

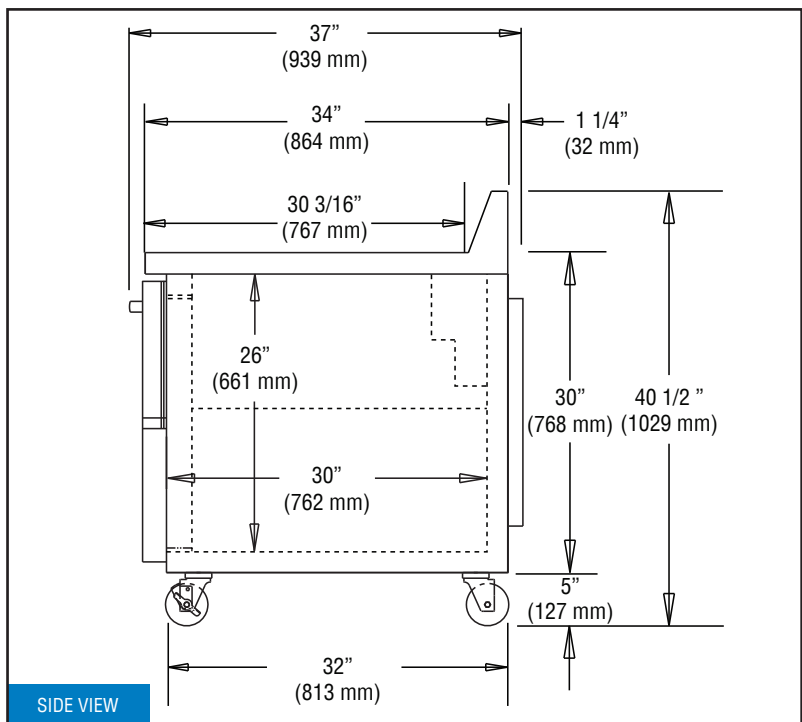
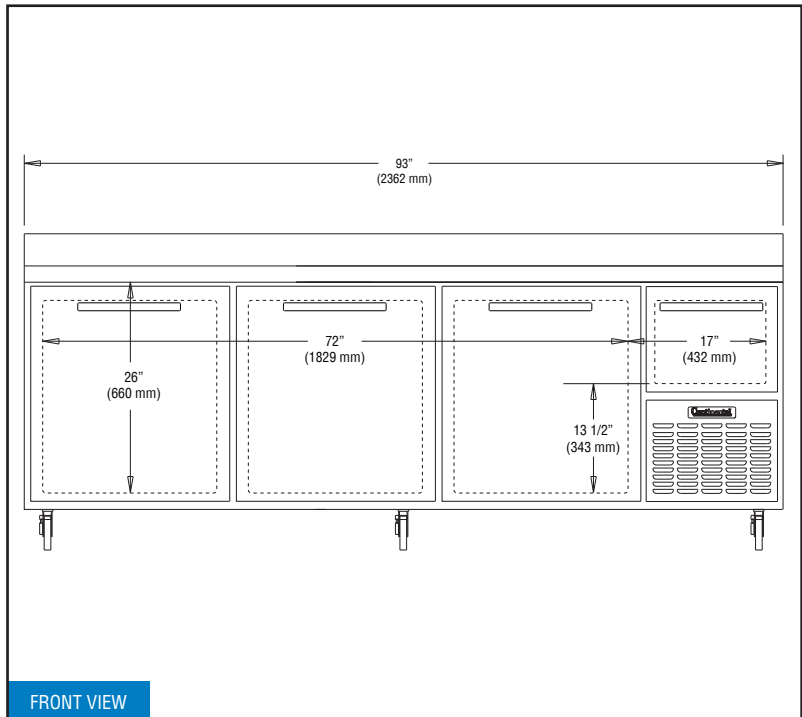

**IMPORTANT NOTE:** If the cabinet is located directly against a wall, a minimum clearance of 3" is required on sides, front and rear.

REVISED: 4/30/26