



UST SERIES

1-SECTION 2-DRAWER COMPACT FLAT LID PREP TABLE



Project Name:	Location:	AIA #:	
Item #:	Qty:	Model #:	SIS #:

UST SERIES - STAINLESS STEEL EXTERIOR & INTERIOR



32" WIDE MODELS TOP RAIL/DRAWER CAPACITY
UST3212-D (12) / (8) in Top & Bottom

SPECIFICATIONS

DIMENSIONAL DATA	
Length in.	31-13/16 (80.8 cm)
Depth in. ³	34-1/2 (87.6 cm)
Height in. ²	36 (91.4 cm)
ELECTRICAL DATA	
Horsepower ¹	1/4
Amps	7.2
Voltage	115/60/1
NEMA	5-15P
REFRIGERATION DATA	
Refrigerant	R-290
Charge Amount oz.	3.5 (99.2 g)
BTU	1525

When ordering please specify:
Voltage and Options



NEMA 5-15P

PLAN VIEW

1. Based on 90°F ambient & 20°F evaporator.
2. Overall height includes 4" (10.2 cm) for casters.
3. Overall depth includes standard cutting board.



Models listed to applicable UL, CSA, and NSF standards by an approved NRTL. Consult the factory or unit data plate for additional information.

Specifications subject to change without notice. Chart dimensions are rounded up to the nearest 1/16" (centimeters rounded up to the nearest tenth).

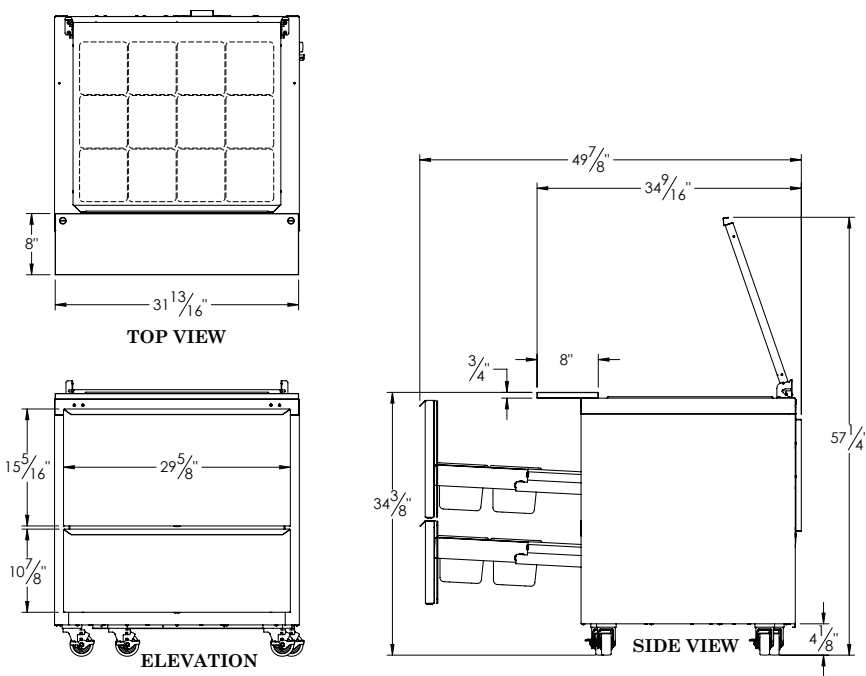



UST SERIES

1-SECTION 2-DRAWER COMPACT FLAT LID PREP TABLE



Project Name:	Location:	AIA #:	
Item #:	Qty:	Model #:	SIS #:

REFRIGERATION SYSTEM

- Self-contained, rear-mounted system uses environmentally friendly, minimal GWP R-290 refrigerant
- Tested to NSF7 standards
- Front-breathing system allows zero-clearance installation
- High performance, balanced system operates at 34-38°F (1.1-3.3°C) to maintain consistent, food-safe temperatures
- Chambered, forced-air rail operation
- Specialized, clock-wise airflow design in cabinet base
- LED display for electronic control is water-resistant
- Capillary tube refrigerant metering
- Forced-air evaporator coil
- Non-electric condensate evaporator

CABINET CONSTRUCTION

- Stainless steel exterior and interior
- Insulated stainless steel lid removable for easy cleaning
- Drawer exterior, liner and frame are constructed of stainless steel
- Exterior back and bottom are constructed of heavy gauge galvanized steel
- Cabinet is insulated with an average of 2" (5.1 cm) thick high density, non-CFC foamed-in-place polyurethane
- Full access to pan rail for easy cleaning
- Includes (12) 4" deep 1/6 size polycarbonate pans; rail accommodates up to 6" deep pans; drawer pans supplied by others
- 8" (20.3 cm) deep, full-length, removable NSF-approved white polyethylene cutting board supplied standard
- Stainless steel divider bars provided
- A set of (4) 4" (10.2 cm) high casters; all with brakes
- 9' (2.7 m) cord & plug provided

DRAWERS

- Drawers are self-closing with a stay-open feature
- Stainless steel drawer slides
- Magnetic, snap-in EZ-Clean™ drawer gaskets are chemical-resistant

FIELD-INSTALLED INTERIOR/SUPPORT OPTIONS

- Set of (4) 2-1/2" (6.4 cm) casters (CK28)
- Set of (4) 2-3/4" (6.9 cm) casters (CK26)
- Set of (4) 3-1/2" (8.9 cm) casters (CK24)
- Set of (4) 6" (15.2 cm) casters (CK20)
- Set of (4) 6" (15.2 cm) legs (LK4)

FACTORY-INSTALLED OPTIONS

- Stainless steel finished back (model number suffix -SB)

WARRANTY

Both a six-year parts and labor warranty, and an additional one-year compressor parts warranty (for a total of seven years) are provided standard

CAD and/or Revit Files Available

<https://traulsen.klclcad.com>

Approved by:	Approved by:	Date:
--------------	--------------	-------