



# SMARTVIDE 9 120/60/1

Maximum capacity: 56 l /14 gal.



P/N 1180143



FOOD PRESERVATION AND SOUS-VIDE  
SMARTVIDE SOUS-VIDE COOKERS

## SALES DESCRIPTION

Commercial high-precision sous-vide cooker. Reliable, user-friendly, portable. Interchangeable between °C and °F.

- ✓ Bluetooth connectivity.
- ✓ HACCP-ready.
- ✓ Optional core probe.
- ✓ Firmware update.
- ✓ Programmable: possibility of storing 20 cooking programs.

## Sous-vide cooking, a technique with many advantages

- ✓ SmartVide guarantees cooking at a **precisely controlled temperature** while preserving the quality of the product, enhancing flavor and texture. Equipped with a highly precise temperature control system to obtain extremely consistent results.
- ✓ An **optional core probe** allows for even more precise control in recipe standardization.
- ✓ Allows cooking food in their own juice and using this juice immediately after cooking to **enhance flavors**.
- ✓ Marinates and macerates an ingredient in **half the time**.
- ✓ **Infuses and flavors** oil, fat or other products applying the controlled temperature technique.
- ✓ Increases **profits** due to lack of product shrink.

## SmartVide 9: designed for chefs, developed with chefs

- ✓ The thick stainless steel, robust construction guarantees commercial performance.
- ✓ Requires **very little hands-on time**, allowing the Chef to do other tasks while the product is being cooked. Just program temperature and time, SmartVide will do the rest.
- ✓ 4 buttons and a full-color TFT display that offers **all the information at a glance** makes operation a child's play. Moreover, thanks to Bluetooth connectivity, an exchange of important data is enabled to enhance the Chef's performance.

- ✓ SmartVide5 is **portable**: thanks to their ergonomic handle, SmartVide5 can be taken from a container to another easily. Additionally, the optional bag allows easy transport - wherever the Chef goes.
- ✓ **HACCP-ready**: thanks to Bluetooth connectivity, it is possible to export or print cooking results at the end of each cycle.
- ✓ **Your appliance, always updated**: free firmware update, no matter where the appliance is.

## INCLUDES

- ✓ Transport bag.

## OPTIONAL

- Core probe.
- Insulated tank.
- Lid for insulated tank.
- Floating balls.
- Janby Track (available through <https://eu.janby.kitchen/es/home>)>janby,kitchen</a>).

## ACCESSORIES

- Needle probe for sous-vide cookers
- Probe foam seal
- Insulated tank for SmartVide immersion circulator
- Lid for SmartVide tanks
- Floating balls for SmartVide
- SmartVide transport bag
- Smooth bags for sous-vide cooking
- Tank dividers

## SPECIFICATIONS

### Temperature

Display precision: 0.01°C  
Range: 5°C - 95°C  
Permissible ambient temperature: 5°C - 40°C

### Time

Resolution: 1'  
Cycle duration: 1' - 99 h

### General features

Maximum recipient capacity: 56 l  
Total loading: 1400 W  
Electrical supply: 120 V / 50-60 Hz / 1~  
Plug: USA (NEMA 5-15P / 2P+G)



SAMMIC, S.L. · Basarte, 1  
20720 AZKOITIA (Gipuzkoa) · SPAIN

product sheet  
updated 10/09/2025



# SMARTVIDE 9 120/60/1

Maximum capacity: 56 l /14 gal.



P/N 1180143

Submergible part dimensions: 117 mm x 110 mm x 147 mm  
 External dimensions (W x D x H): 124 mm x 140 mm x 360 mm  
 Net weight: 4.2 kg

Crated dimensions  
 440 x 190 x 310 mm  
 Gross weight: 5.8 kg

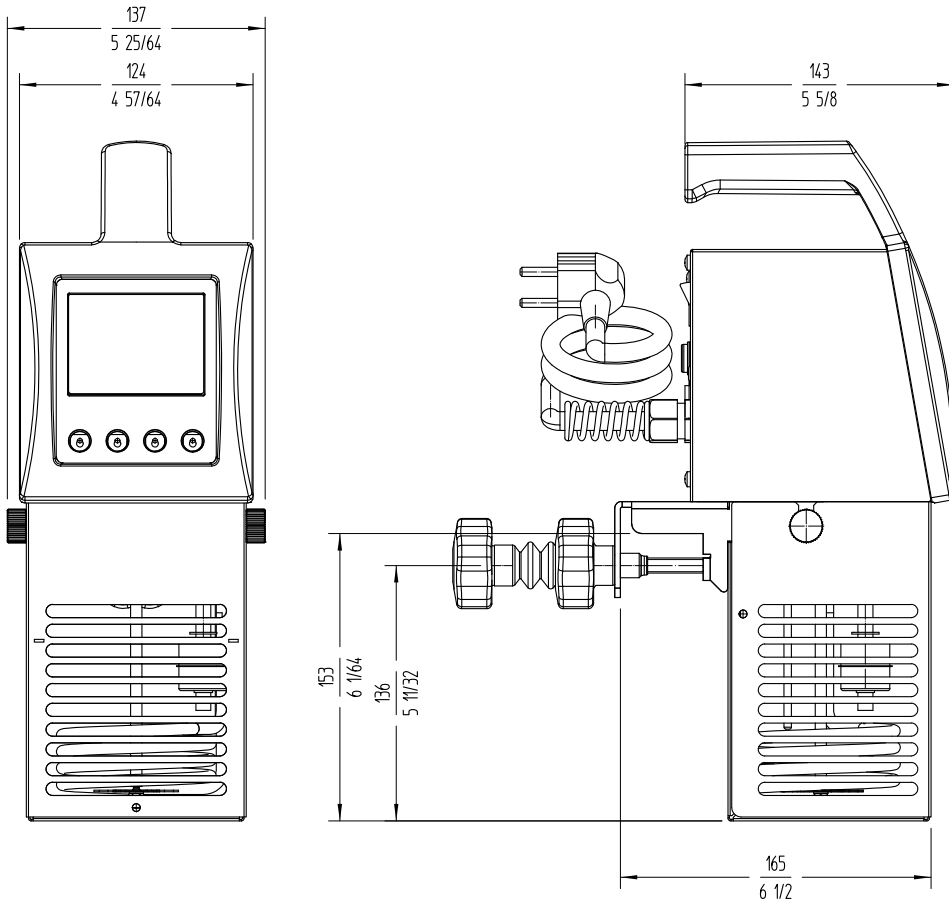

FOOD PRESERVATION AND SOUS-VIDE  
 SMARTVIDE SOUS-VIDE COOKERS

**sammic** | sammic.com  
 Food Service Equipment Manufacturer

Polígono Basarte, 1. phone +34 943 15 72 36  
 20720 Azkoitia, Spain sales@sammic.com



Project	Date
Item	Qty
Approved	

product sheet  
 updated 10/09/2025