



Founded in 1946

Project: \_\_\_\_\_

Items: \_\_\_\_\_

Quantity: \_\_\_\_\_

Approval: \_\_\_\_\_

Date: \_\_\_\_\_

## Stainless Steel / Aluminum Mobile Lug Carts

Store and transport products with the Mobile Lug Carts. The perfect solution to cut down product handling time.

### Features:

- Constructed of all welded aluminum (AL) and stainless steel (SS)
- **Lifetime Warranty Against Rust**
- 10" Spacing between runners
- Rolling Capacity: 1200 lbs
- Maneuvers easily on (4) 5" swivel polyurethane casters.
- **Lugs are sold separately**

### Benefits:

- Multipurpose cart designed for storage and transportation of kitchenware and more.
- Minimize lifting and carrying
- Sanitary and easy to clean
- Safely and efficiently transport items
- Ensures conformance to FDA rule that requires the storage of all fresh produce be at least 6" above the floor.



AL-L-6



AL-L-2



AL-L-1





Founded in 1946

# Stainless Steel / Aluminum Mobile Lug Carts

**AL-L-6 Specs**

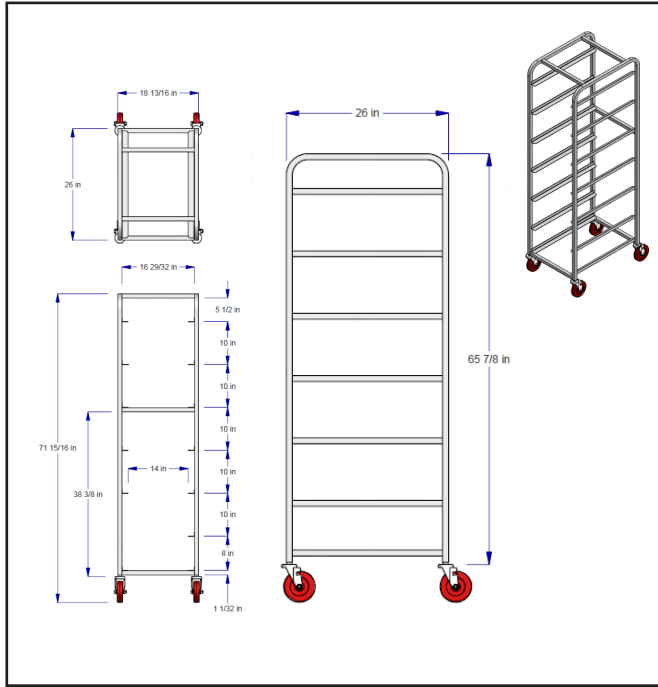

**AL-L-2 Specs**

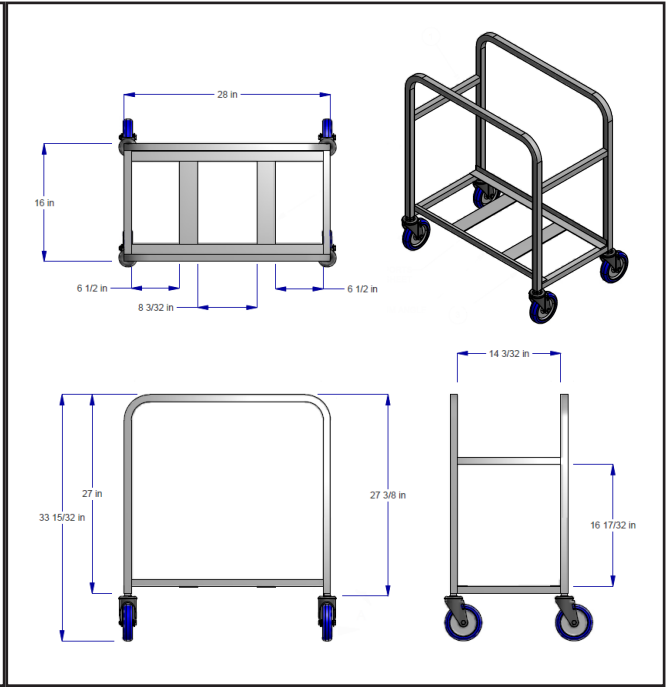

Model Number	Order#	Overall Dimensions			Lug Capacity	Approx. Ship Wt (lb)
		Width (in)	Length (in)	Height (in)		
<b>Aluminum</b>						
AL-L-1	104176	16	25	19	1	12
AL-L-1-WM	240784	16	25	26 ½	1	13
AL-L-2	104230	16	28	33 ½	2	14
AL-L-3	104264	19	27	41	3	16
AL-L-6	104281	19	27	71	6	22
<b>Stainless Steel</b>						
SS-L-1	104310	16	25	19	1	15
SS-L-2	104336	16	28	33 ½	2	23
SS-L-3	104361	19	27	41	3	33
SS-L-6	104387	19	27	71	6	40

**Caster Information:**  
 (4) 5" Swivel Polyurethane Casters 757  
**Freight Class: 250**

**Option for Aluminum Models:**  
**XB XTRA Heavy Duty Reinforced Upright**



In line with our policy to continually improve our products, Winholt reserves the right to change materials and specifications without notice.