

**MAIN FEATURES**

- A pistol-style, handheld and easy-to-operate vacuum sealer
- Trigger operation allows for sealing delicate and softer products
- Features a heavy-duty base for charging and storage
- Reduce food waste and eliminate freezer burn
- Increase profits by extending the shelf life of ingredients
- Hygienically protect food from contamination and bacteria
- 25 one-quart and 25 one-gallon storage bags, safe for microwave, freezer and boiling
- Ideal for sous-vide cooking

**ELECTRICAL**

Voltage: 120

Frequency: 60Hz

Plug Type: 5-15P

**SALES FEATURES**

Increase profitability and reduce food waste with the WVS50 Waring® Vacuum Sealing System. This pistol-style, easy-to-use, handheld vacuum sealer is great for sous-vide cooking. It increases the shelf life of your ingredients by eliminating freezer burn and protecting food from the effects of microorganisms. Trigger operation allows you to vacuum seal softer and delicate products.



@waringcommercial

©2022 Waring Commercial  
314 Ella T. Grasso Avenue, Torrington, CT 06790  
Tel. 800-492-7464 • Fax 860-496-9008

[waringcommercialproducts.com](http://waringcommercialproducts.com)



# Vacuum Sealing System WVS50

## PARTS & ACCESSORIES



**WVSQT** Quart Vacuum Bags

## DIMENSIONS

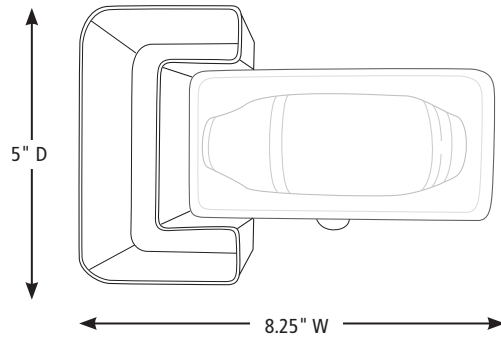
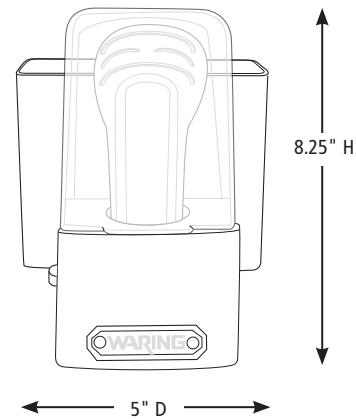
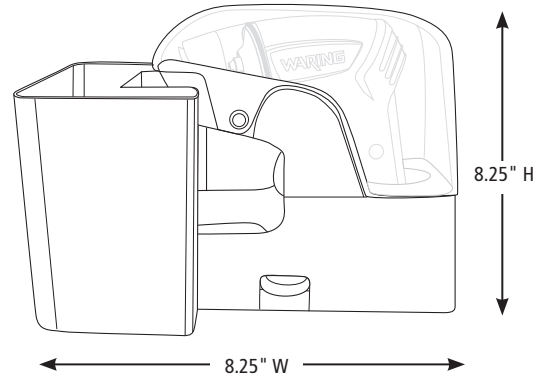

Out of Box Weight: 5.5 lb.

ORDERING INFORMATION	#STD. PKG.	GIFTBOX WEIGHT	CUBIC FEET	BOX DIMENSIONS D X W X H	UPC	CASE PKG.	MC WEIGHT	MC DIMENSIONS D X W X H	MBC
WVS50 – Vacuum Sealing System	1	7	.56	11.5" x 10.875" x 8.25"	040072022517	2	14	10.875" x 11.5" x 8.25"	10040072022514



@waringcommercial

©2022 Waring Commercial  
314 Ella T. Grasso Avenue, Torrington, CT 06790  
Tel. 800-492-7464 • Fax 860-496-9008

waringcommercialproducts.com

21WC081659 / REV 10/21