

Item# _____
Project: _____
Qty: _____

Electric Fryers

EF-06L



EF-06L-2



Features

- Stainless steel construction
- Stainless steel heating element for high efficiency
- EF-06L single basket / EF-06L-2 dual basket
- Durable heavy duty baskets
- 1.5 gallon (6L) oil capacity per basin
- Thermostatic control
- Hi-limit over heat protection 446° F
- Operational temperature range 140-375° F
- 120 volt / 60 hz / 1 phase with NEMA 5-15 plug
- 6 month replacement parts only warranty

Serv-Ware



Serv-Ware
www.servware.com

Phone:(800).768.5953

Revised 5/18

Fax:(800).976.1299



Item# _____

Project: _____

Qty: _____

Electric Fryers

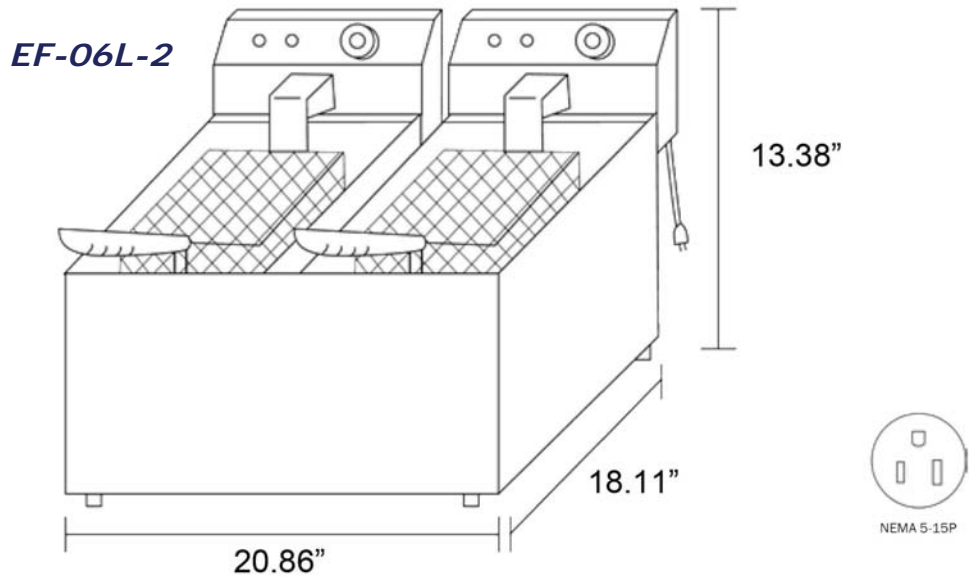
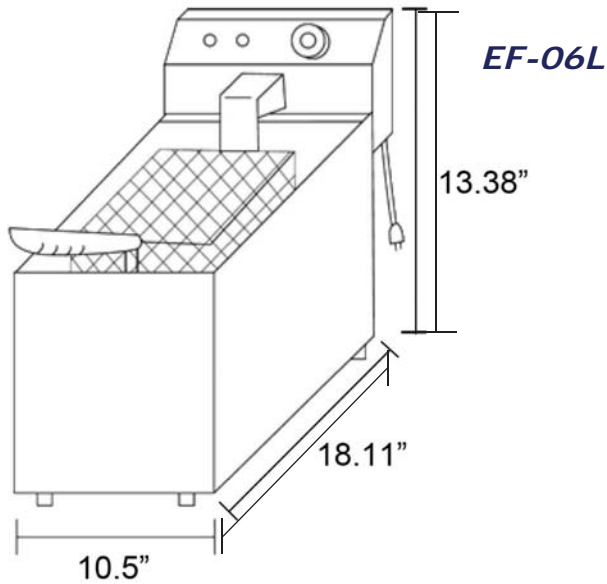

Serv-Ware

Model	Watts/ Volts/Hz	Outside Dimensions (W x D x H)	Weight (Shipping)
EF-06L	1800W/120V	10.5" x 18.11" x 13.38"	29 lbs.
EF-06L-2	1800W (2) / 120V	20.86" x 18.11" x 13.38"	58 lbs.



Serv-Ware
www.servware.com

Phone: (800).768.5953

Revised 5/18

Fax: (800).976.1299

