



Catalogue
FOOD SERVICE
Chapter
COOK & CHILL

Specific model
APW-101-G NG R SW S K 230V 1N 50Hz

19103757

11/10/2023

DENOMINATION:

iKORE oven Advance (touch control panel), PureSteam (boiler models) with intelligent washing system for 10 trays GN 1/1, gas heating.

DESCRIPTION :

FUNCTIONS:

- 10.1" glass state of the art touch screen for easy and intuitive operation
- iCooking: Smart cooking process with automatic adjustment:
 - . Options at the end of the cooking process: maintain temperature, repeat cooking process, etc.
 - . Ability to modify smart cooking processes in progress and adjust parameters at any time
- Additional functions (regeneration, sous vide, overnight cooking, fermentation, pasteurisation, smoking, charcuterie and dehydration). Smart cooking processes with automatic adjustment
- iClima:
 - . Humidity management and control by means of direct measurement with a humidity sensor
 - . 1% regulation capacity
- Fagor Cooking Center:
 - . 200 factory preset and culinary tested recipes
 - . Ability to manage your favourite recipes
 - . Unlimited 9-stage recipe storage capacity
- Air and water cool-down (rapid cabinet cooling function)
- Multitray
- Cooking modes: low temperature steam 30-98°, steam 99°, super steam 100- 130°, mixed 20-300° and convection 20-300°
- Chamber dehumidification for crispy roasts
- DeltaT cooking for delicate cooking
- PURESTEAM:**
 - Higher steam saturation in the chamber than an injection oven
 - Pure steam generator with automatic filling function
 - Impurities in the water are deposited in the boiler, facilitating the maintenance of the oven and an impurity-free cooking chamber.
 - Steam generator equipped with limescale detector.
- Automatic and adjustable emptying of the generator every 24 hours of cooking.
- Limescale detection system
- Semi-automatic descaling system
- Guided descaling programme
- CONTROLS:**
 - EasyCooking: option to configure the programmes by password
 - Languages: 36
 - Ability to configure screen tone, volume and contrast
 - Tones: 8
 - Power, network and language settings
 - Integrated help functions and instruction manual
 - Control and monitoring of the equipment from mobile devices via FagorConnect
 - SAT and Trade fair mode
- EQUIPMENT FEATURES:**
 - Stop/start function
 - EZ-Sensor: Internal probe with 4 measuring locations
 - Positioning aid for temperature sensor
 - Manual steam injection
 - Automatic dehumidification system

DIMENSIONS

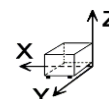

X Width	898 mm	X Gross width	980 mm
Y Depth	922 mm	Y Gross depth	1055 mm
Z Height	1117 mm	Z Gross height	1340 mm
Net Weight	148,0 kg	Gross Weight	178,0 kg
Net volume	0,820 m3	Gross volume	1,385 m3

ELECTRICITY TECHNICAL SPECIFICATIONS

Engine power	0,60 kW
Electric power	0,830 kW
Amperage (A)	6,2A
Heating power	0,23 kW
Voltage	230V - 1N
Electric frequency	50Hz

GAS TECHNICAL SPECIFICATIONS

Gas power	18,00 kW
Regulated	NG G20/G25/G25.1 20/25/25 mbar

WATER TECHNICAL SPECIFICATIONS

Pressure	H2O: 200-400kPa(2-4bar)
Water max consumption	10,00 L/h

CONNECTIONS TECHNICAL SPECIFICATIONS

Single-phase 230V wiring	2X1,5MM ² +T-10A
Gas diameter 1	R.3/4"G
Steam exit diameter	53
Air entrance diameter	50
Water inlet diameter	3/4"
Drain 1 diameter	40
SubFamilia	38,00 mm

OTHERS

Door opening	Right
--------------	-------

TECHNICAL FEATURES

Number of trays	10
-----------------	----





Catalogue
FOOD SERVICE
Chapter
COOK & CHILL

Specific model
APW-101-G NG R SW S K 230V 1N 50Hz

19103757

11/10/2023

- Variable humidification with 5 levels
- 6 programmable air circulation speeds (from 1400 rpm to turbine stop)
- Option to switch from °C to °F
- Energy consumption display
- Display of actual values and selected values
- Delayed programming
- JIT (just in time) programming
- Ability to select 1/2 power
- Automatic adaptation to the characteristics of the installation site (altitude, etc.) including initial self-testing
- Automatic boiling point adjustment
- Removable fan cover
- Integrated turbine brake for increased safety
- HA-Control: bidirectional turbine that provides intelligent even heat distribution
- Auto-reverse system for reversing fan rotation
- Triple-glazed, ventilated cooking chamber door (all except 0623)
- Special heat-reflective coating and hinged inner panes for easy cleaning
- LED lighting in the cooking chamber
- HOLD-OPEN DOOR systems (3 door locking positions for user safety)
- Proximity contact door switch
- Easily replaceable gasket insert
- Interior and outer material: AISI 304 stainless steel (interior mirror polished)

CERTIFICATION AND INSTALLATION SYMBOLS:

- EC declaration of conformity
- EC declaration of gas conformity
- CB safety
- IPX5 protection against splashes and jets of water
- Height adjustable equipment feet (all except 0623)
- Monitor App and maintenance App (self-diagnosis of warnings and errors)
- Logging App:
 - . Cycle history
 - . Error history

FAGORKONNECT:

- Wi-Fi and ETHERNET connection as standard
- Functions when the oven is connected or not to the internet.

WASHING SYSTEM:

- iWashing (environmentally and economically efficient)
- Choice of iWashing Solid or iWashing Liquid smart washing systems
- Washing programmes:
 - . 1 basic cleaning programme (spray)
 - . 3 automatic cleaning programmes
 - . 1 rinsing programme
 - . 1 polishing programme
- Option to activate dirt softening during the cleaning process
- Option to activate drying in the cleaning process
- Indication of cleaning status and remaining time
- Control and monitoring of the cleaning process from mobile devices via FagorKonnnect

SPECIFIC OPTIONS :

- ELECTRIC POWER : 230V 1N 50HZ - 101
- FUSE DEFINITION : 061-101-062-102 G
- BRAND : FAGOR
- GAS : NG NATURAL GAS





Catalogue
FOOD SERVICE
Chapter
COOK & CHILL

Specific model
APW-101-G NG R SW S K 230V 1N 50Hz

19103757

11/10/2023

- DOOR OPENING : R RIGHT
- WASHING SYSTEM : SW-IWASHING SOLID
- SHOWER : S-RETRACTIL SHOWER
- RACK : GN TRAY
- SOUS VIDE & THERMAL PROBE : NO
- CONNECTIVITY : K-WITH IOT CONNECTIVITY
- CERTIFICATION : CE
- REG 4: WITH REG 4

POSSIBLE ACCESSORIES :

- CONVERSION KITS
- CLEANING ACCESSORIES
- COOKING ACCESSORIES O
- SUPPORTS OVENS
- STRUCTURES AND TROLLEYS
- FASTENING KIT
- THERMICAL COVER
- PASTRY GUIDES
- VARIOUS
- KIT BAFFLE



Catalogue
FOOD SERVICE
Chapter
COOK & CHILL

Specific model
APW-101-G NG R SW S K 230V 1N 50Hz

19103757

11/10/2023

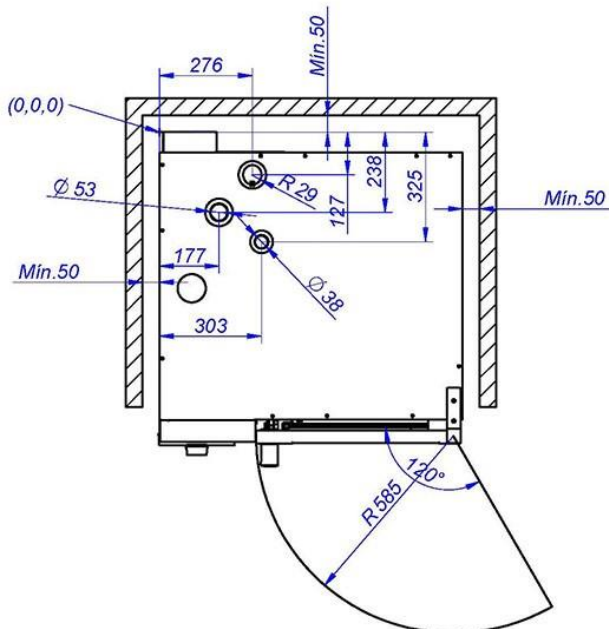
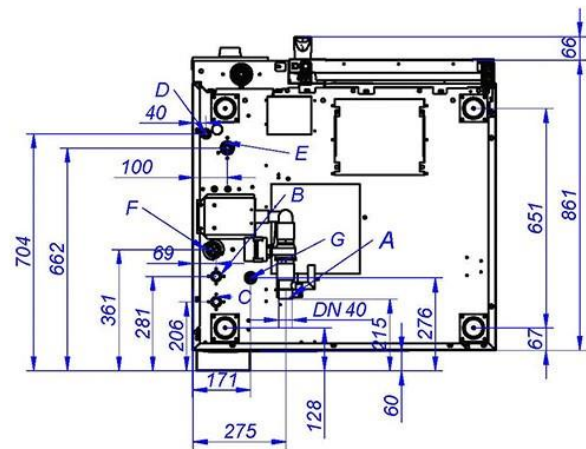
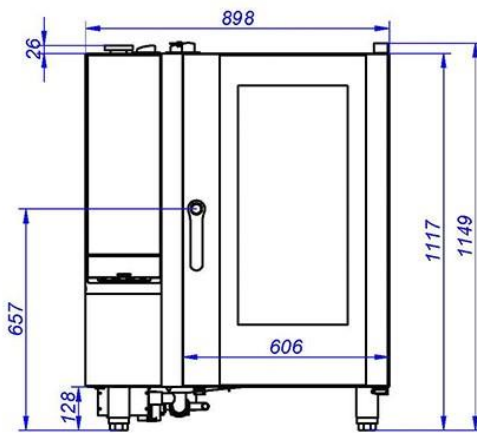

- A: DRAIN CONNECTION DN40
- B: SOFT WATER CONNECTION
- C: SOFT WATER CONNECTION
- D: ELECTRICAL SUPPLY
- E: GAS INLET
- F: AIR INLET
- G: ETHERNET