

Mobile Hot Food Counter

Standard Features

FRAME: Featuring frameless construction utilizing 16 gauge stainless steel formed end panels with top and bottom horizontal members of 16 gauge stainless steel.

CASTERS: Heavy duty 5" diameter plate casters with gray rubber tires. Brake models to be supplied on all casters.

TOP: 14 gauge stainless steel with 2" turndown on all sides and sound deadening applied between top and frame.

FRONT BODY PANEL: Removable stainless steel or plastic laminate front panel.

UNDERSHELF: 18 gauge stainless steel with 18" high ends and 4" high back. Undersheff is held back 6" from front panel forming a utility chase for plumbing and electrical services.

HOT FOOD UNITS: 12" x 20" individually controlled units rated at 1000 watts each with infinite switches.

STAINLESS STEEL SPECIFICATION: All stainless steel to be type 304 with number 4 finish.

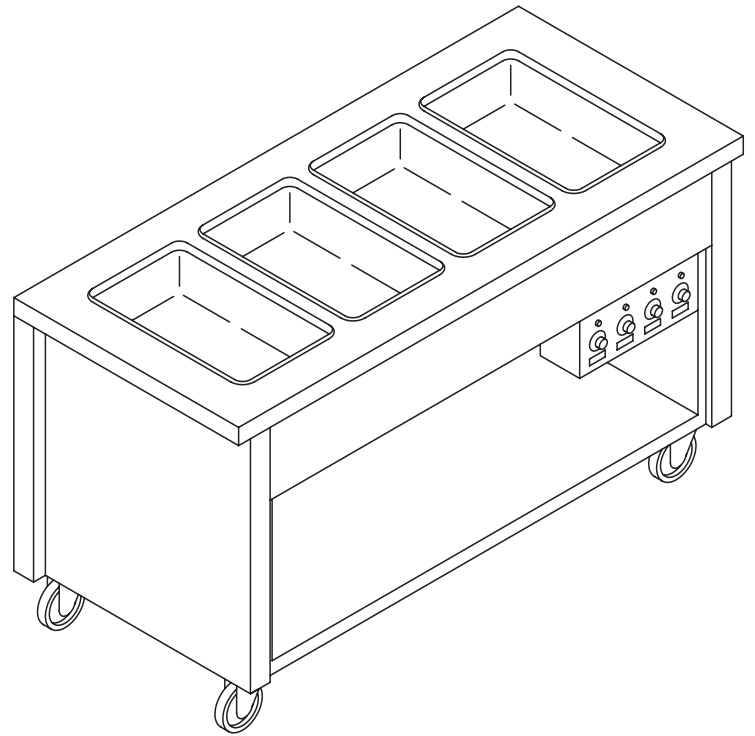

MODEL	LENGTH	PAN CAPACITY	WATTS	VOLTS	PHASE	NEMA AMPS	APPROX. CORD/CAP	SHIP WEIGHT
MCT-HF2	36"	2	2000	120/208	1	10.6	NEMA L14-20P	350 lbs
MCT-HF3	50"	3	3000	120/208	1	15.4	NEMA L14-20P	440 lbs
MCT-HF4	64"	4	4000	120/208	1	20.2	NEMA L14-30P	525 lbs
MCT-HF5	78"	5	5000	120/208	3	19.2	NEMA L21-30P	600 lbs
MCT-HF6	92"	6	6000	120/208	3	20.2	NEMA L21-30P	690 lbs



Mobile Hot Food Counter

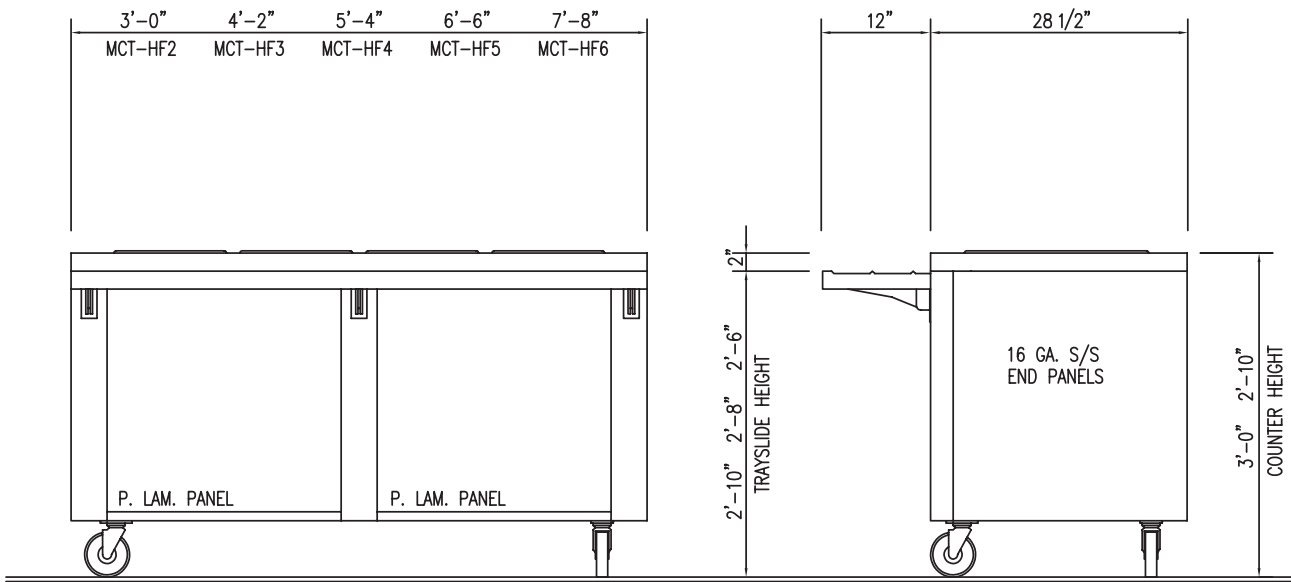

Optional Features

FRONT BODY PANEL: Ceramic tile front panel.

TRAYSLIDE: Stainless steel or Corian® trayslide mounted on fold down brackets. Stainless steel tubular trayslide also available, on fold down brackets.

FILL FAUCET: Hot water pantry faucet mounted on top along with drain manifold will allow filling of all hot food units simultaneously.

HOSE: Quick disconnect hose for fill faucet.

WORKSHELF: 16 gauge stainless steel 8" wide shelf mounted at rear on fold down brackets.

PLATESHELF: 16 gauge stainless steel 8" wide shelf mounted at rear on fold down brackets.

MANIFOLD DRAIN: Drain outlets manifolded to common globe valve.

FLUORESCENT LIGHT: Pre-wired fluorescent light fixture with safety shields and toggle switch.

HEAT LAMP: Heat strip w/incandescent lights.

SERVING SHELF: 16 gauge stainless steel or Corian® single serve with 1 1/2" turndown on all sides. Support post of 1 1/4" 18 gauge stainless. Includes sneeze-guard of 3/8" thick high grade Lexan® with polished edges.

DISPLAY SHELF: 16 gauge stainless steel or Corian® two-tier shelf with 1 1/2" turndown on all sides. Support post of 1 1/4" 18 gauge stainless. Includes sneeze-guard of 3/8" thick high grade Lexan® with polished edges.

BUFFET SERVICE: Dual service shelf with dual service sneeze-guard of 3/8" thick high grade Lexan® with polished edges.

BUN PAN RECESS: Heated recess to accommodate 18 x 26 inches sheet pans.

OPTIONAL COUNTER/TRAYSLIDE HEIGHT:
 Elementary schools – 34" counter / 30" trayslide
 Middle School – 34" counter / 32" trayslide
 High School – 36" counter / 34" trayslide

ADDITIONAL WARRANTY: Additional 12 month limited warranty on parts and labor.

For options / accessories / modifications not shown, please contact factory.

Mod-U-Serve reserves the right to modify specifications or discontinue models without notice or incurring obligation.



2320 Peyton Houston, Texas 77032
 Phone 281-442-8001 Toll Free: 888-955-5463 Fax: 281-442-3351 www.mod-u-serve.com

MUS.5 11/05