



KM-1601S_J(Z)(3)

STACKABLE CRESCENT CUBER



KM-1601S_J(Z)(3)
07/02/24
Item # 13104

Item #: _____
 Project: _____
 Qty: _____
 AIA#: _____

W x D x H
48" x 27^{3/8}" x 27^{3/8}"

Shipping Dimensions
51^{3/4}" x 33" x 33.5"

KM|EDGE™

KM-1601SAJ
Air-Cooled 1 Phase
Shown on optional bin: B-900

KM-1601SWJ
Water-Cooled 1 Phase

KM-1601SRJZ ★
Remote Air-Cooled 1 Phase

KM-1601SAJ3
Air-Cooled 3 Phase

KM-1601SWJ3
Water-Cooled 3 Phase

KM-1601SRJZ3
Remote Air-Cooled 3 Phase



Features

- ▶ Individual crescent cube
- ▶ Stainless steel evaporator
- ▶ CycleSaver™ design

- Up to 1671 lbs. of ice production per 24 hours
- Stackable for 3342 lbs. per 24 hours ice production in the same floor space
- Durable stainless steel exterior
- EverCheck™ alert system
- R-404A Refrigerant

Available on Bins:

B-800 **B-1150SS** **B-1500SS** *Top kit may be required.*
B-900 **B-1300SS** **B-1650SS** *See Bin Spec Sheets.*

Warranty:

Valid in United States, Canada, Puerto Rico and U.S. Territories. Contact factory for warranty in other countries.



Condenser	Model	ICE PRODUCTION		WATER USAGE			ELECTRICAL							
		Air / Water Temp Lbs. per 24 hours 70°/50°F	90°/70°F	Potable Gal. per 100 lbs. 90°/70°F	Condenser Gal. per 100 lbs. 90°/70°F	kWh Used per 100 lbs. 90°/70°F	Min. Circuit/ Max. Fuse Size	Amperage	Voltage	Circuit Wires (including ground)	Heat Rejection BTU/hr.	Refrigerant Charge Amount	Net / Ship Weight (lbs.)	
1 Phase	Air	KM-1601SAJ	1513	1433	21.0	N/A	4.24	20A	15.9A	208-230V/60/1	4*	18,500	5 lbs. 1.1 oz.	275 / 345
	Water	KM-1601SWJ	1660	1650	19.7	100	3.30	20A	13.6A	208-230V/60/1	4*	21,300	2 lbs. 10.3 oz.	310 / 335
	Remote	KM-1601SRJZ	1640	1600	17.6	N/A	3.96	20A	15.9A	208-230V/60/1	4*	21,200	15 lbs. 3.4 oz. 22 lbs. 15 oz.†	300 / 315
3 Phase	Air	KM-1601SAJ3	1513	1414	21.0	N/A	4.40	20A	12.9A	208-230V/60/3	4	16,400	5 lbs. 1.1 oz.	275 / 350
	Water	KM-1601SWJ3	1671	1660	18.5	90	3.32	20A	8.8A	208-230V/60/3	4	19,900	2 lbs. 10.3 oz.	310 / 345
	Remote	KM-1601SRJZ3	1635	1600	18.0	N/A	4.14	20A	12.8A	208-230V/60/3	4	20,000	15 lbs. 3.4 oz. 22 lbs. 15 oz.†	300 / 355

*If neutral is not available, transformer kit (HS-5030) is required. Refer to Instruction Manual for installation and electrical requirements.

†with condenser
Power cord not included

KMEdge™ Cube Dimensions*

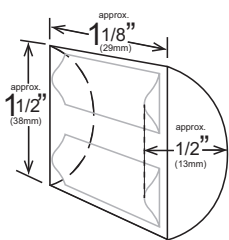

* approximate size in inches, image not to scale

Operating Limits

- Ambient Temp Range 45 - 100°F
- Water Temp Range 45 - 90°F
- Water Pressure 10 - 113 PSIG
- Voltage Range 187 - 253V
- If GFCI is required, a GFCI breaker MUST be used in lieu of GFCI receptacle

Service

- Panels easily removed and all components accessible for service.
- Allow 9" (23 cm) clearance at rear, sides, and top for proper air circulation and ease of maintenance/service.

Plumbing

- Icemaker Water Supply Line: Min. 3/8" Nominal ID Copper Water Tubing or Equivalent
- Icemaker Drain Line: Min. 3/4" Nominal ID Hard Pipe or Equivalent **Water-Cooled Model (Lines Must Be Independent of Icemaker)**
- Condenser Water Supply Line: Min. 3/8" Nominal ID Copper Water Tubing or Equivalent
- Condenser Drain/Return Line: Min. 3/8" Nominal ID Hard Pipe (open drain system) or Copper Water Tubing (closed loop system) or Equivalent

Water Filter

Please refer to water filter spec sheet for recommended configurations.

Hoshizaki reserves the right to change specifications without notice.



KM-1601S_J(Z)(3)

STACKABLE CRESCENT CUBER

KM-1601S_J(Z)(3)

07/02/24

Item # 13104

FRONT VIEW

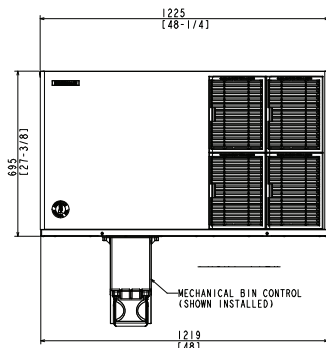

AIR-COOLED

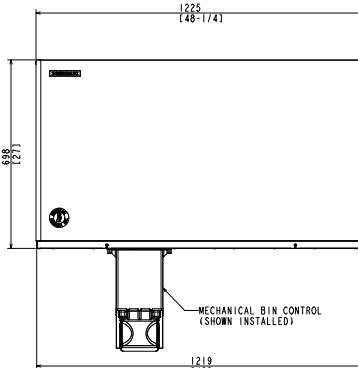

WATER-COOLED

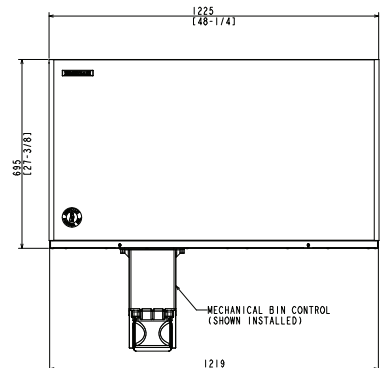

REMOTE AIR-COOLED

SIDE VIEW

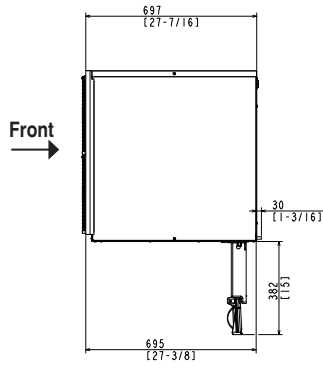

AIR-COOLED

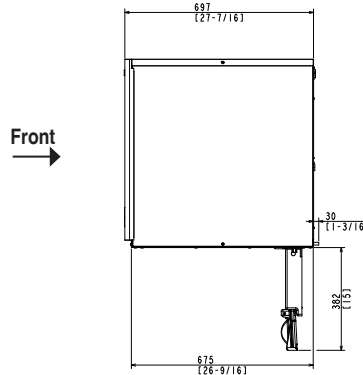

WATER-COOLED

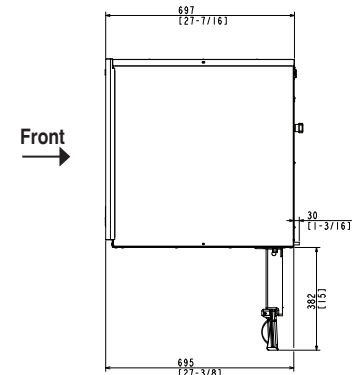

REMOTE AIR-COOLED

REAR VIEW

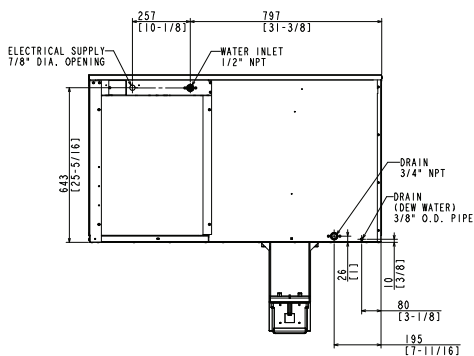

AIR-COOLED

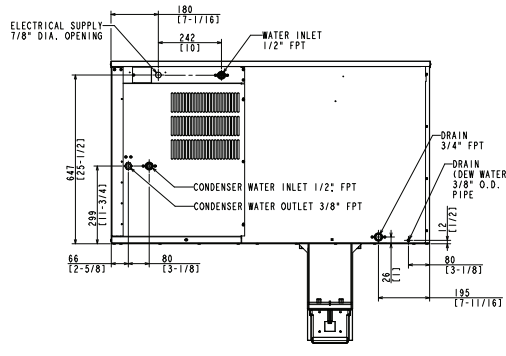

WATER-COOLED

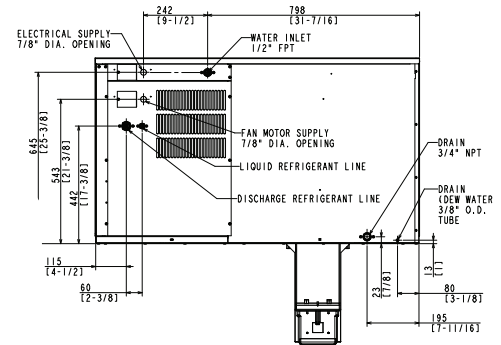

REMOTE AIR-COOLED

BOTTOM VIEW

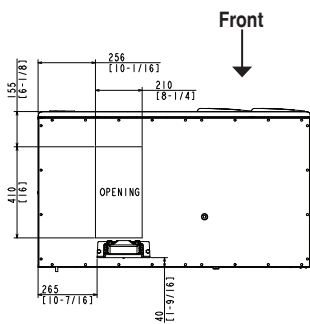

AIR-COOLED

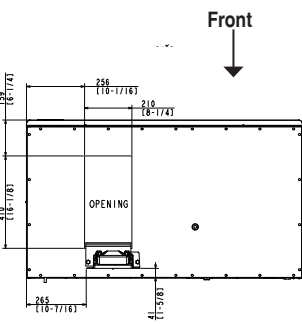

WATER-COOLED

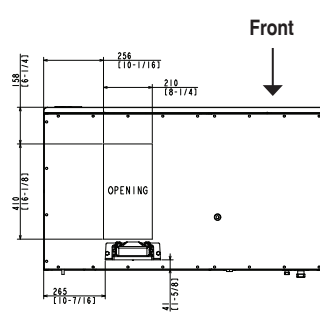

REMOTE AIR-COOLED

URC-22FZ Remote Condenser (Sold Separately)
(W x D x H) 46 3/8 X 14 1/16 X 40 1/2
For Use with KM-1601SRJZ(3)

Brazed Line Sets
(Sold Separately)
25' HS-5323
35' HS-5324
55' HS-5325

Voltage supply for the URC Remote Condenser is supplied from the Ice Maker. No additional circuit is required.

