



## Millivolt Control **FRYERS**

### Features

- The Ikon Gas Fryer line has a tube heat exchange design that incorporates fast temperature recovery and large cold zone.
- Stainless steel fry tanks are completely pressure blasted (peened) for smoother finish and easy cleaning.
- 30,000 BTU / burner
- Models: 3, 4, & 5 tube
- Millivolt (snap action) thermostat, 200°F - 400°F
- Stainless steel front and door
- Sides and back are galvanized steel
- Large cold zone to trap food particles
- 1-1/4" dia. full port drain valve for fast and complete oil draining
- 4, 6" adjustable Stainless Steel legs standard, casters optional
- Drain pipe holder attached to inside door
- Twin nickel plated baskets
- Superior construction, finish, & appearance
- Available in Natural gas(NG) or Liquid Propane(LP)





# Millivolt Control FRYERS

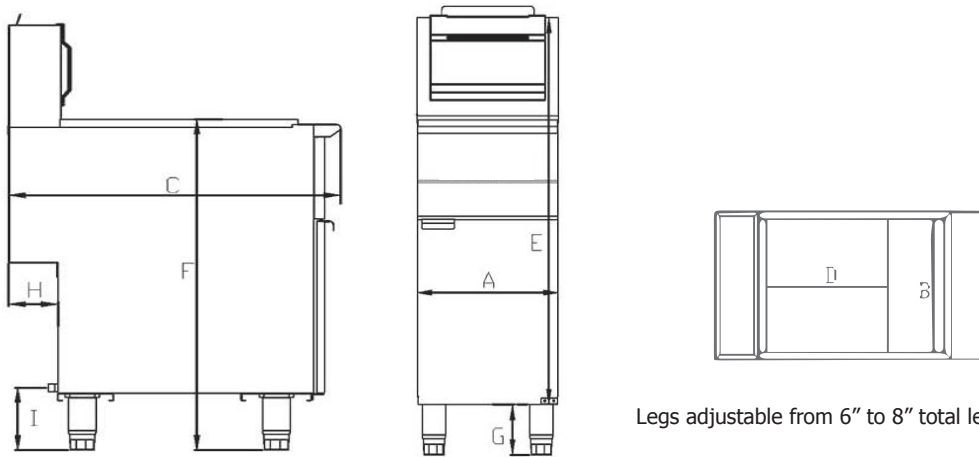

Legs adjustable from 6" to 8" total leg height

## Specifications

Model	Width		Depth		Height			Clearance		Weight	Shipping Dimensions	Ship. Weight
	A	B	C	D	E	F	G	H	I			
IGF-35/40-NG	15.5"	14.0"	30.8"	14.0"	39.4"	34.7"	6.0"	4.2"	7.0"	133 lbs	18.5"W x 33.5"D x 33.1"H	150 lbs
IGF-35/40-LP	(39.4cm)	(35.5cm)	(78.2cm)	(35.5cm)	(100cm)	(88.1cm)	(15.2cm)	(10.6cm)	(17.8cm)	(60.4kg)	(47cm x 85.1cm x 84cm)	(68.2kg)
IGF-40/50-NG	15.5"	14.0"	30.8"	14.0"	39.4"	34.7"	6.0"	4.2"	7.0"	140 lbs	18.5"W x 33.5"D x 33.1"H	158 lbs
IGF-40/50-LP	(39.4cm)	(35.5cm)	(77.0cm)	(35.5cm)	(100cm)	(88.1cm)	(15.2cm)	(10.6cm)	(17.8cm)	(63.6kg)	(47cm x 85.1cm x 84cm)	(71.8kg)
IGF-75/80-NG	21.0"	18.0"	34.3"	18.0"	39.4"	34.7"	6.0"	4.2"	7.0"	210 lbs	24.4"W x 37.4"D x 33.1"H	265 lbs
IGF-75/80-LP	(53.3cm)	(45.7cm)	(87.1cm)	(45.7cm)	(100cm)	(88.1cm)	(15.2cm)	(10.6cm)	(17.8cm)	(95.5kg)	(62cm x 95cm x 84cm)	(120.5kg)

Model	Oil Capacity	Gas Type	Heat Tubes	Tube BTU's	Total BTU's
IGF-35/40	35-40 lbs	Natural	3	30,000	90,000
IGF-35/40	35-40 lbs	LP	3	30,000	90,000
IGF-40/50	40-55 lbs	Natural	4	30,000	120,000
IGF-40/50	40-55 lbs	LP	4	30,000	120,000
IGF-75/80	75-80 lbs	Natural	5	30,000	150,000
IGF-75/80	75-80 lbs	LP	5	30,000	150,000

### GAS REQUIREMENTS

- Natural Gas or Liquid Propane (LP) Gas main supply required
- 3/4" NPT gas connection
- Natural gas 4" W.C., LP gas 10" W.C.
- Units are not supplied with conversion kits.
- Gas type must selected before ordering

