



Project _____
 AIA # _____ SIS # _____
 Item # _____ Quantity _____ C.S.I. Section 114000



LXeC CHEMICAL SANITIZING Undercounter Dishwashing Machine



STANDARD FEATURES

- + 34 racks per hour
- + .74 gallons of water per rack
- + Accommodates optional second level rack kit
- + Chemical sanitization unit
- + Low chemical alert indicators
- + Delime notification with cycle
- + Chemical pump “auto-prime”
- + Advanced service diagnostics
- + Deep drawn stainless steel tank
- + Top mounted digital controls with status indicators
- + Revolving upper and lower interchangeable anti-clogging wash arms
- + Revolving upper and lower interchangeable rinse arms
- + Removable stainless steel scrap screen
- + Corrosion resistant pump
- + Automatic pumped drain
- + 17" door opening
- + Automatic fill
- + Detergent, rinse aid and sanitizer pumps standard
- + Electric tank heat
- + Two dishracks – one peg and one combination rack

OPTIONS & ACCESSORIES (Available at extra cost)

- Second level rack kit
- Power cord kits
- Stainless steel base with 6" legs
- 17" stainless steel stand with storage
- External low height caster kit
- Internal caster kit (3")
- DWT-LXe drain water tempering kit – to comply with plumbing codes
- Splash reduction panels
- Water hammer arrestor kit
- Pressure regulator valve



SPECIFIER STATEMENT

Specified unit will be a NSF rated chemical sanitizing undercounter dishwasher operating on a hot water supply only with a 17" door opening. Features second level racking with optional second level rack kit, low chemical and delime notifications, .74 gallons per rack, LED temp and operator display, service diagnostics, detergent, sanitizer and rinse aid pumps. Constructed of stainless steel.

1-year parts and labor warranty.

LXe SERIES – LXeC CHEMICAL SANITIZING

Approved by _____ Date _____ Approved by _____ Date _____



LXeC CHEMICAL SANITIZING Undercounter Dishwashing Machine

LEGEND

| Electrical Connections | |
|------------------------|--|
| E1 | Electrical connection: 1-3/8" dia. hole for 1" trade size conduit; 4-5/8" AFF. |
| Plumbing Connections | |
| P1 | Single fill and rinse connection: 3/4" female garden hose fitting on 6' long hose supplied with machine; 120°F water min. for LXeC, 140°F recommended. |
| P2 | Drain connection: 5/8" barb fitting with 6' long hose supplied with machine. |

WARNING: Plumbing and electrical connections should be made by qualified personnel who will observe all the applicable plumbing, sanitary, safety codes and National Electrical Code.

Required flowing pressure to the dishmachine is 15-65 PSIG. If pressures higher than 65 PSIG are present, a pressure regulating valve must be installed in the water line to the dishmachine (by others).

Pressure gauge not required on pumped rinse machines.

Miscellaneous Notes: Backflow prevention provided by NSF-approved air gap device.

(E1) STANDARD ELECTRICAL OPTIONS

| Tank Heat, Booster, Pump & Controls | | | |
|-------------------------------------|------------|---------------------------------|---------------------------|
| Voltage | Rated Amps | Minimum Supply Circuit Ampacity | Maximum Protective Device |
| 120/60/1 | 13.4 | 20 | 20 |

NOTE: For supply connections, use copper wire only rated at 90°C minimum. Accessory cord kit available for all machines. Dishmachine not provided with internal GFCI protection.

SPECIFICATIONS

Capacities

| | |
|-------------------------|-----|
| Cycle Time (seconds) | 105 |
| Racks per Hour | 34 |
| Tank Capacity – Gallons | 2.9 |

Motor Horsepower

| | |
|-------|------|
| Wash | 0.85 |
| Rinse | 0.19 |

Water Consumption

| | |
|---|------|
| U.S. Gallons per Rack (maximum use) | 0.74 |
| U.S. Gallons per Hour (maximum use) | 25.0 |
| Peak Drain Flow – U.S. Gallons (gallons per minute) | 4.0 |

Temperatures °F

| | |
|--|-----|
| Incoming Water Temperature (minimum recommended) | 120 |
|--|-----|

Heating

| | |
|--------------------------|-----|
| Tank Heat, electric (kW) | 1.8 |
|--------------------------|-----|

Standard 20" x 20" (508 x 508) Rack Complement

| | |
|------|---|
| Flat | 1 |
| Peg | 1 |

Shipping Weight (approximate) 170 lbs.

Crated Dimensions 28"W x 30"L x 37"H

| Heat Output, BTU/Hour | |
|-----------------------|----------|
| Latent | Sensible |
| 1,900 | 800 |

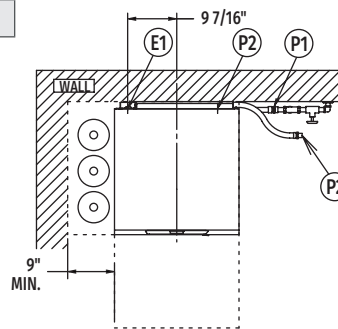

Top View

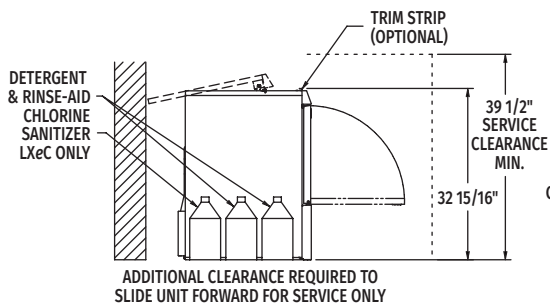

Left Side View

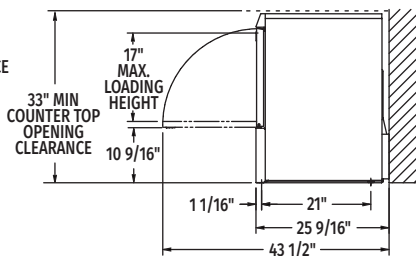

Right Side View

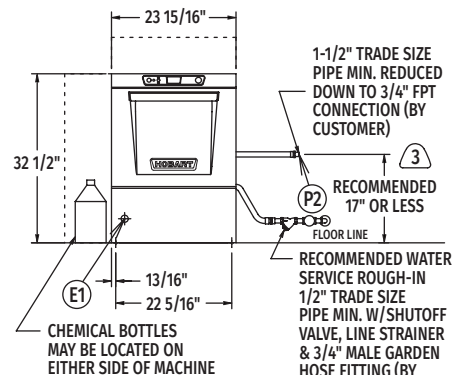

Front View

MODEL:
LXeC
00-947871
REV C

As continued product improvement is a policy of Hobart, specifications are subject to change without notice.

CAD and/or Revit Files Available