

GARLAND®

G-Series 60" Raised Griddle/Broiler Gas Range With Flame-Failure & Electronic Ignition

Project _____
 Item _____
 Quantity _____
 CSI Section 11400
 Approved _____
 Date _____

Models

- GFE60-6R24RR
- GFE60-6R24RS



Model GFE60-6R24RR

Standard Features

- Flame-failure protection: all burners
- Electric spark ignition on all burners, requiring single-phase 115V 60Hz or 240V 50Hz (specify)
- Large 27" (686mm) work top surface
- Stainless steel front and sides
- Stainless steel 5" (127mm) plate rail
- Stainless steel low-profile backguard
- 12" (305mm) section stamped drip trays w/ dimpled bottom
- 6" (152mm) adj. stainless steel legs
- Large phenolic knobs
- Gas regulator
- Reinforced chassis
- Ergonomic split cast-iron top ring grates
- 26,000 BTU/7.61 kW 2-piece cast-iron Starfire® open top burner
- 24" (610mm) raised griddle/broiler section on right side only W/ 3 cast-iron burners each rated 11,000 BTU/3.22 kW, w/one manual hi/lo valve per burner
- Two broiler rack settings at 3-3/4" (95mm) and 2-1/2" (64mm)
- 5/8" (15mm) thick steel griddle plate w/ manual hi/lo valve control, 23" (584mm) working depth surface, standard on right, optional on left
- 4-1/4" (108mm) wide grease trough
- 38,000 BTU/ 11.13 kW cast-iron "H" style oven burner
- Snap-action modulating oven

- thermostat low to 500° F
- Easy to access oven pilot
- Nickel-plated oven rack and 3-position removable oven rack guide
- Large porcelain oven interior, fits standard sheet pans in both directions for standard ovens
- Square-cornered door design with strong, "keep-cool" oven door handleOpen storage in lieu of oven, (suffix S)

Options & Accessories

- Hot top 12" (305mm) plate in lieu of two open burners, manual valve controlled w/ 18,000 BTU/5.27 kW cast-iron "H" burner standard on left side
- Stainless steel backguard with removable high shelf
- Additional oven racks
- Four 6" (152mm) levelling swivel casters w/front locking
- Flanged deck mount legs
- Celsius temperature dials

Specifications

Gas restaurant series range with large capacity standard oven.

59 1/16" (1500mm) wide and 27 1/4" (686mm) deep work top surfaces.

Total flame-failure protection for all burners.

Electric spark ignition on all burners, requiring single-phase 115V 60Hz or 240V 50Hz (specify)

Stainless steel front, sides and 5" (127mm) wide front rail.

6" (152mm) legs with adjustable feet.

Six Starfire® 2-piece, 26,000 BTU/7.61 kW, cast open burners set in split cast-iron ergonomic grates.

24" (610mm) raised griddle/broiler section on right

side only with 3 cast-iron burners each rated a 11,000 BTU/3.22 kW.

Optional hot-top with cast-iron "H" style burners, 18,000 BTU/5.27 kW (natural gas), in lieu of open burners.

Porcelain oven interior.

Heavy cast-iron "H" oven burner rated 38,000 BTU/11.13 kW (natural gas)

Oven controlled by even-bake, fast recovery snap-action modulating oven thermostat.

Available with storage base in lieu of standard oven.

NOTE: Use only Garland certified casters and approved restraining devices.



Garland Commercial Ranges Ltd.
 1177 Kamato Road,
 Mississauga, Ontario
 L4W 1X4 CANADA

General Inquires 1-905-624-0260
 USA Sales, Parts and Service 1-800-424-2411
 Canadian Sales 1-888-442-7526
 Canada or USA Parts/Service 1-800-427-6668

www.garland-group.com
 8086D
 01/26



G-Series 60" Raised Griddle/Broiler Gas Range / Flame-Failure & Electronic Ignition

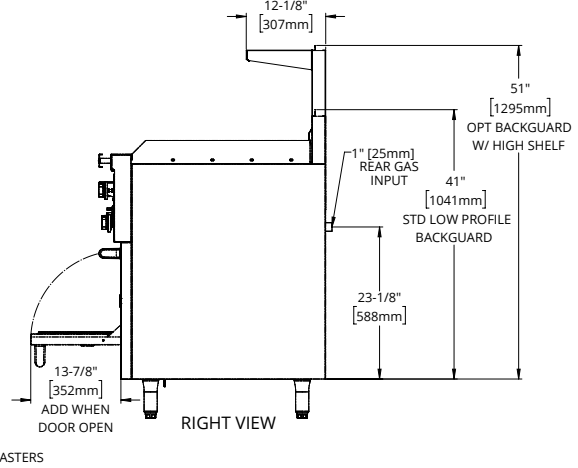
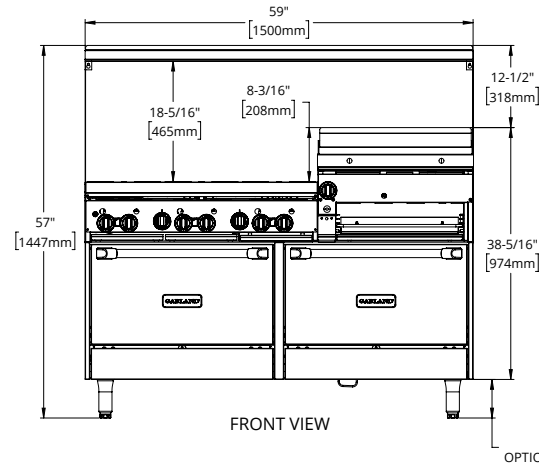
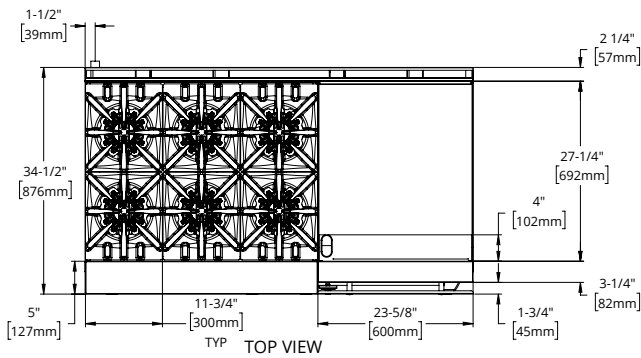

Gas input ratings shown for installations up to 2000 ft., (610m) above sea level. Please specify altitudes over 2000 ft.

This product is not approved for residential use.

Note: Installation clearance reductions are applicable only where local codes permit.

Model Number	Description	Total BTU/ Hr Natural	Shipping Information	
			Lbs./Kg	Cu Ft
GFE60-6R24RR	6 Open Burners, 24" Raised Griddle/Broiler w/ (2) Standard Ovens	265,000	828/376	81
GF60-6R24RS	6 Open Burners, 24" Raised Griddle/Broiler w/ (1) Standard Ovens & Storage Base	227,000	787/357	81

Width In (mm)	Depth In (mm)	Height w/LPBG In (mm)	Oven Interior In (mm)			Storage Base Interior In (mm)			Combustible Wall Clearance-In (mm)		Entry Clearances In (mm)	
			Height	Depth	Width	Height	Depth	Width	Sides	Rear	Crated	Uncrated
59 (1500)	34-1/2 (876)	47 (1194)	13 (330)	26 (660)	26-1/4 (667)	18-1/4 (464)	26-3/8 (670)	26-3/16 (655)	14 (3565)	6 (152)	37 (940)	36-1/2 (927)

LPBG = Low Profile Backguard

Burner Ratings (BTU/Hr/kW)					Manifold Operating Pressure
Gas Type	Open Top	Hot Top	Standard Oven	Raised Griddle/Broiler	
Natural	26,000/7.61	18,000/5.27	38,000/11.13	33,000/9.66	4.5" WC, 11 mbar
Propane	26,000/7.61	18,000/5.27	32,000/9.38	33,000/9.66	10.0" WC, 25 mbar

Electrical Supply: GFE models with 115V 60 Hz 1-phase, 0.1 amps; 6 ft. (1.8m) power cord with NEMA 5-15P plug. Power cord not supplied with 240V 50 Hz 1-phase 0.05 amps models.

Garland reserves the right to make changes to the design or specifications without prior notice.

Garland Commercial Ranges Ltd.
1177 Kamato Road,
Mississauga, Ontario
L4W 1X4 CANADA

General Inquires 1-905-624-0260
USA Sales, Parts and Service 1-800-424-2411
Canadian Sales 1-888-442-7526
Canada or USA Parts/Service 1-800-427-6668

www.garland-group.com
8086D
01/26

