

# Spec sheet

## iCombi® Classic 6-half size E/G

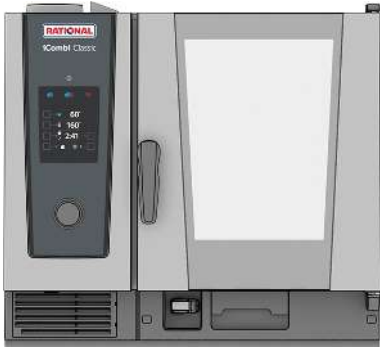

### Capacity

- > Six (6) Half-size sheet pans or Six (6) Steam table pans or Six (6) 1/1 GN accessories
- > Removable standard hinging rack with 2 5/8 inch rack spacing (68 mm)
- > Large selection of accessories for various cooking procedures, such as grilling, braising or baking
- > For use with 1/1, 1/2, 2/3, 1/3 GN accessories and optional baker's standard accessories (400 x 600 mm)

### Combi-steamer mode

- > Steaming 86 °F - 266 °F
- > Convection 86 °F - 572 °F
- > Combination of steam and convection 86 °F - 572 °F

### ClimaPlus

- > Climate management – humidity measurement and control
- > Humidity setting in 10-% increments

### Description

- > Combi-steamer in accordance with DIN 18866 for most cooking methods used in commercial kitchens for optional use of steam and convection, individually, one after the other, or combined.
- Ventilation approvals: The electrical appliance conforms to the EPA 202 test in accordance with ANSI/NFPA 96 "Ventilation Control and Fire Protection of Commercial Cooking Operations" Refer to UL Listing KNLZ.E148536 (America) or KNLZ7.E148536 (Canada).

### Unit description and functions

#### Cooking functions

- > ClimaPlus: The active climate management in the cooking cabinet, which constantly measures and controls the humidity and guarantees effective dehumidification, combined with high productivity, cooking quality and low energy consumption. Humidity can be adjusted in increments of 10% and monitored via the digital display for precise manual cooking
- > Dynamic air circulation in the cooking cabinet through reversing high-performance fan propeller with five fan speeds that can be programmed manually. The optimal energy yield results in excellent uniformity and short cooking times.
- > High-performance steam generator for optimal steaming performance even at low temperatures below 212°F
- > Integrated, maintenance-free fat separation system without an additional fat filter
- > Cool-down function for quick cooling of the cooking cabinet via a fan propeller
- > Core temperature measurement via core temperature probe and optional positioning aid (accessories)
- > Delta-T cooking for extremely gentle preparation with minimal cooking losses
- > Digital temperature display, can be set to °C or °F, displays target and actual values
- > Cooking cabinet humidity and time displayed digitally; displays target and actual values
- > Individual programming of up to 100 single or multi-stage cooking programs with up to 12 steps
- > Individual adjustment of the cooking parameters time, temperature and humidity for a program step during ongoing operation
- > Easy transfer of cooking programs to other cooking systems via USB stick.
- > Integrated hand shower with automatic retraction and switchable spray/jet function
- > Energy-saving, long-lasting LED lighting in the cooking cabinet, with excellent color fidelity to allow quick determination of cooking progress
- > No-charge 4-hour RATIONAL certified chef assistance program

#### Occupational and operating safety

- > Electronic safety temperature limiter for steam generator and hot air heating
- > Integrated fan wheel brake
- > Maximum cooking cabinet door touch temperature of 73 °C
- > Maximum cooking cabinet door touch temperature of 163 °F
- > HACCP data storage and output via USB or optional storage and management in the cloud-based networking solution ConnectedCooking
- > HACCP data storage and output via USB
- > Tested according to national and international standards for unattended operation
- > Gas appliances: H2 Ready - approved and certified (KIWA) for operation with gas mixtures containing up to 20 % hydrogen by volume
- > Maximum drawer height not higher than 63 inches when using a RATIONAL underframe
- > Ergonomic door handle with right/left opening and slam function

#### Networking

- > Integrated, IP-protected USB interface for local data exchange
- > Optional integrated IP-protected Ethernet interface
- > Optional integrated Wi-Fi interface (incl. Ethernet interface)

#### Cleaning and care

- > Automatic, water pressure-independent cleaning and maintenance system for cooking cabinet and steam generator
- > Care system: Automatic cleaning and descaling of the steam generator
- > 4 cleaning programs of varying degrees for unsupervised cleaning, even overnight
- > Easy and intuitive operation of the cleaning programs: Display of the selected cleaning program, the recommended quantity of tabs and the remaining cleaning time

- > Safe ending of the cleaning in the event of a power failure with no cleaning agent left in the cooking cabinet
- > Use of phosphate and phosphorous-free Active Green cleaner tabs and care tabs
- > Hygienic setup flush with the counter without feet for easy and safe cleaning
- > Unit door with rear-ventilated double glass panel and hinged inner pane for easy cleaning
- > Inside and outside material: stainless steel DIN 1.4301, seamless hygienic cooking cabinet with rounded corners and optimized air flow
- > Glass and stainless steel surfaces allow easy, safe external cleaning; IPX5-class protection against spraying water in all directions

#### Operation

- > 4.3 inch TFT color display and softkeys for easy and intuitive operation. Operating modes and functions are visually highlighted
- > Easy operation and exact settings through a central dial with push function
- > Acoustic prompts and visual messages when user action is required
- > Recirculating hoods (accessories) with situational adjustment of extraction power and service message transmission.

#### Installation, maintenance and environment

- > Professional installation by RATIONAL-certified technicians recommended
- > Rear in-direct floor drain with air gap is required, and should be supplied in alignment with local code.
- > Adaptation to the installation site (height above sea level ) through automatic calibration
- > Operation without water softener and without additional manual descaling possible
- > Installation flush with the floor and wall through connection in the base area \*
- > Double-pane glass door with heat reflective special coating for minimal energy losses
- > Service diagnostic system with automatic service message display
- > Regular maintenance is recommended. Maintenance according to manufacturer recommendations available from RATIONAL service partners
- > Energy efficiency in accordance with ENERGY STAR tested and passed. Published at [www.energystar.gov](http://www.energystar.gov)
- > 2-year RATIONAL warranty including parts, labor, and travel and 5-year steam generator warranty\*\*
- > \* See the installation or planner manual for details
- > \*\* Terms and conditions apply, see manufacturer warranty statement at [www.rational-online.com](http://www.rational-online.com)

#### Options

- > Hinging rack and air baffle for baker's standard accessories (400 x 600 mm)
- > Cooking cabinet door, left-hinged
- > MarineLine – ship version
- > SecurityLine – prison / security version
- > MobilityLine - mobile version (available to order as a separate accessory)
- > HeavyDutyLine – particularly resilient version
- > Integrated fat drain
- > Mobile oven rack package
- > Safety door lock
- > Protection for control panel
- > Lockable control panel
- > Integrated, IP-protected Ethernet interface
- > Integrated Wi-Fi interface (incl. Ethernet interface)

## Technical specifications

### Dimensions and weights

Dimensions (W x H x D)	
Cooking system (body)	33 1/2 x 29 5/8 x 30 1/2 inches
Cooking system (total)	33 1/2 x 31 5/8 x 33 1/8 inches
Cooking system with packaging	36 3/4 x 37 3/4 x 37 5/8 inches
Maximum working height of top level*	≤ 5 ft. 2 7/8 inches

\*When using an original RATIONAL stand

Weights	
Maximum load size per level	33 lb
Maximum total load capacity	66 lb
Weight - electric unit without packaging	209 lb
Weight - electric unit with packaging	251 lb
Weight - gas unit without packaging	243 lb
Weight - gas unit with packaging	284 lb

### Electrical connection conditions

Voltage 3 ph 208 V / 240 V	
Connected loads - electric	10.8 kW
Steam power	9 kW
Convection power	10.25 kW
Maximum circuit breaker	40 A / 35 A
Running AMPS	30 A (208 V) / 26 A (240 V)
Cable diameter	AWG 8 194°F
Voltage 3 ph 440 V / 480 V	
Connected loads - electric	10.8 kW
Steam power	9 kW
Convection power	10.25 kW
Maximum circuit breaker	20 A / 20 A
Running AMPS	14.2 A (440 V) / 13 A (480 V)
Cable diameter	AWG 12 194°F
Voltage 1 ph 208 V / 240 V	
Connected loads - electric	10.8 kW
Steam power	9 kW
Convection power	10.25 kW
Maximum circuit breaker	70 A / 60 A
Running AMPS	52 A (208 V) / 45 A (240 V)
Cable diameter	AWG 4 194°F

### Connected loads - gas

Natural gas G20	
Nominal heat load, total	49500 BTU
Nominal heat load, Steam mode	45500 BTU
Nominal heat load, Hot Air mode	49500 BTU
Required connection flow pressure	6.5 – 10 inch w.c.
Liquid gas	
Nominal heat load, total	48500 BTU
Nominal heat load, Steam mode	44500 BTU
Nominal heat load, Hot Air mode	48500 BTU
Required connection flow pressure	10 – 15 inch w.c.

3/4" NPT with 3/4" gas shut off

Additional gas types and voltages available on request

### Connected loads - exhaust air and thermal load

Voltage 1 ph 208 V	
Connected loads - gas	0.6 kW
Breaker	15 A
Running AMPS	2.9 A
Voltage 1 ph 120 V	
Connected loads - gas	0.6 kW
Breaker	15 A
Running AMPS	5.0 A

All gas units are supplied with a 6 ft cord.

### Connection conditions water

Connection	3/4" GHT
Supply minimum	1/2" ID Drinking Quality Cold
Water pressure (flow pressure), each	14.5-87.0 psi
Maximum flow rate per cooking system	3 gal/min
Water drain, each	2" OD
Max short-term amount of wastewater	0.11 gal/sec

Use only high-temperature resistant drain pipe

### Water quality requirements

Untreated water can be 0 to 24.5 gr/gal (0 to 420ppm) hardness. We do not recommend treated water hardness < 5 gr/gal (86ppm) because the water could be corrosive. Sodium ion exchangers are not recommended; H+ Ion exchange systems are recommended. Water that does not meet the following minimum standards will require the proper conditioning

Contaminant	Water Requirements	If > than recommended
Sand / Particles	< 15 µm	Particle filter
Chlorine (Cl <sub>2</sub> )	< 0.012 gr/gal (0.2 ppm)	Active carbon filter
Chloride (Cl <sup>-</sup> )	< 4.68 gr/gal (80 ppm)	RO

All RATIONAL iCombi Pro & Classic models meet the requirements for LEED, IGCC and any local codes that have adopted them, based on water consumption and efficiency.

Model	XS	6 half size	6 full size	10 half size	10 full size	20 half size	20 full size
gal/hr	0.9	1.8	3.5	3.3	5.9	6.4	9.2
gal/hr/pan	0.3	0.3	0.3	0.3	0.3	0.3	0.2

### Connected loads - exhaust air and thermal load

Latent heat load	1943 BTU
Sensible heat emission	2391 BTU
Sound level (electric)	55 dBA
Sound level (gas)	60 dBA

### Connection loads - data

LAN data interface	RJ45
WiFi data interface	IEEE 802.11 a/g/n

### Minimum distances at installation

#### Clearance Requirements

To facilitate servicing, we recommend leaving a 20" (500 mm) gap on the left-hand side of the unit. If there is not 20" (500 mm) left side clearance available, provisions for moving the unit to the left for service access must be made. Such provisions include, but are not limited to, having quick connections (water, gas, etc.) and lengthened electrical connections with flexible cords.

If there are no external heat sources acting on the unit, there should be at least 2" (50 mm) of clearance on either side of the unit. On the back, single units and electric Combi-Duo vent pipe can be mounted flush with the wall. 2" rear clearance from the gas Combi-Duo exhaust gas box. If a high temperature heat source is on the left or right side of the unit, clearance of at least 14" (350 mm) must be maintained on the respective side. This clearance may be reduced to 2" (50 mm) if a heat shield is used (see accessories).

Recommended clearance from unobstructed rear exhaust pipes and any surface collecting grease or flammable material; 16" (400 mm) gas, 10" (254 mm) electric. It is recommended to have a hood overhang of 6" (150 mm) to 18" (450 mm) at the front of the unit and 6" (150 mm) on the sides if installed at the end of the cooking line. Please refer to the Installation Manual for additional technical data and for instructions on installation and setup.

**Installation conditions**

- > Observe all local and country-specific standards and regulations regarding the installation and operation of industrial cooking appliances. The local standards and regulations for interior ventilation systems must also be taken into account.
- > Do not connect to any receptacle that local code requires protection by a UL 943 listed Class A GFCI. The device is approved for field hardwiring per local code.

**Approvals**



**NSF Certification**

iCombi Pro (LM100) and iCombi Classic (LM200) are NSF-certified, shown on the NSF list.

Technical drawing, electrical

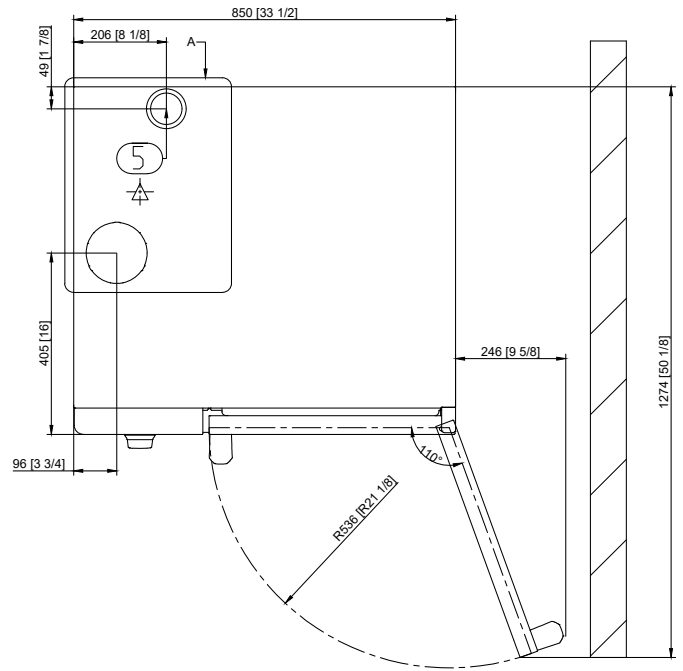
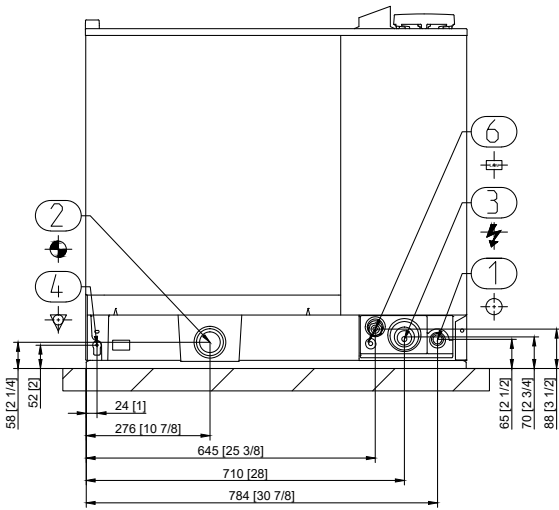
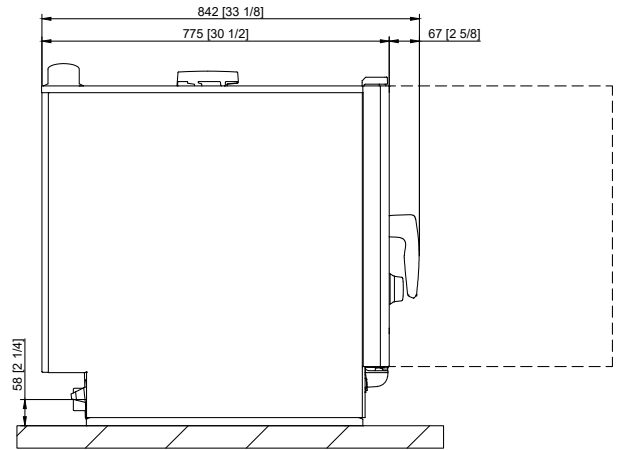
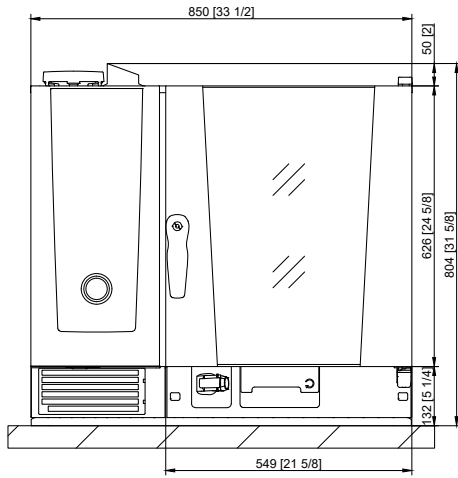

1	Water inlet
2	Water drain
3	Electrical connection
4	Equipotential bonding
5	Ventilation pipe



Technical drawing, gas

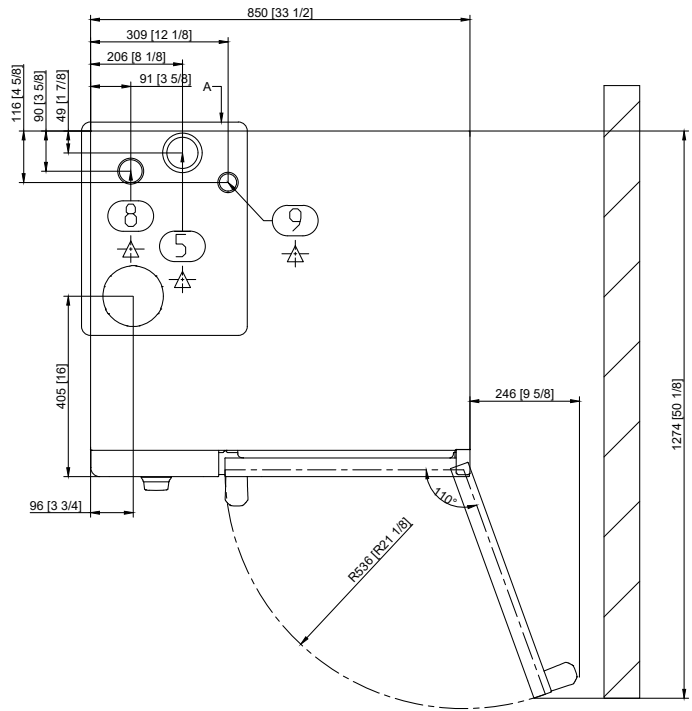
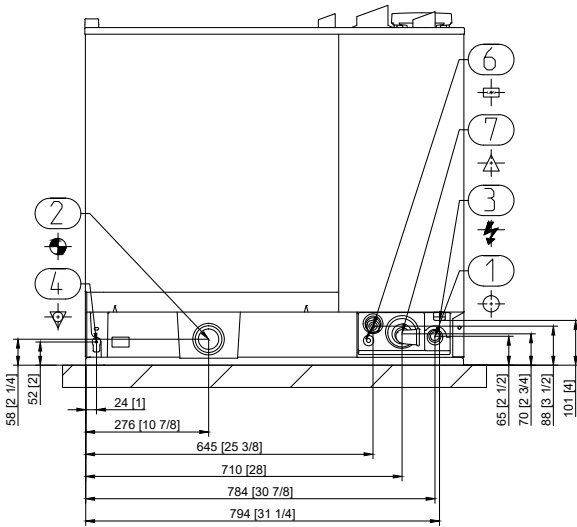
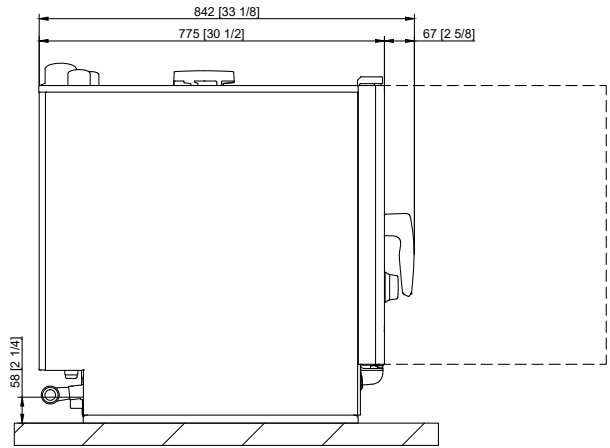
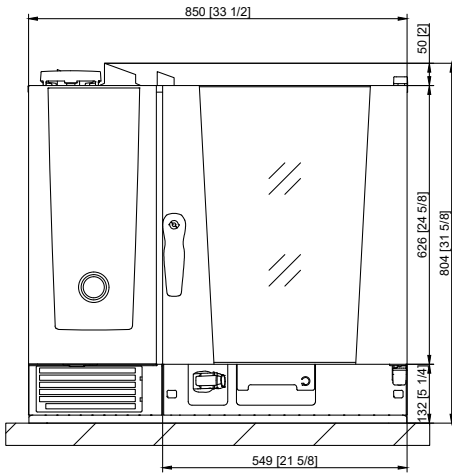

1	Water inlet
2	Water drain
3	Electrical connection
4	Equipotential bonding
5	Ventilation pipe

6	Ethernet interface
7	Gas connection
8	Exhaust pipe gas (steam)
9	Exhaust pipe gas (convection)

## Accessories

Accessories	Item number
RATIONAL Active Green cleaning agent tabs – guarantee the best cleaning performance	Item no. 56.01.535
RATIONAL Care tabs – effectively prevent limescale deposits	Item no. 56.00.562
Condensation breaker – diverts steam and vapors to an existing exhaust air system Sizes 6-half size, 10-half size, 6-full size and 10-full size	Item no. 60.72.592
Run-in rail for mobile rack and mobile plate rack Size 6-half size, 10-half size	Item no. 60.75.115
Finishing system for banquets Size 6-half size, 20 plates	Item no. 60.61.741
Mobile oven rack and mobile plate oven rack – for simple loading outside the cooking system	See Cooking Systems and Accessories catalog
Hinging racks - Size 6-half size	Item no. 7 racks 60.61.624 Item no. 5 racks 60.61.615
Heat shield – for installing a unit near a heat source, e.g. a grill - Size 6-half size	Item no. left side 60.75.110 Item no. right side 60.75.113
Mobile catering stand - especially for heavy mobile catering usage	Item no. 60.31.164
Stackable Combi-Duo kit Size 6-half size E/G on Size 6-half size E or Size 10-half size E	Item no. 60.73.991
Stackable Combi-Duo kit - Size 6-half size E/G on Size 6-half size G	Item no. right-side hinges 60.75.751 Item no. left-side hinges 60.75.753
Transport trolley for mobile rack and mobile plate rack - height-adjustable - Sizes 6-full size, 10-full size	Item no. 60.75.606
Transport trolley for mobile rack and mobile plate rack - standard - Sizes 6-half size, 10-half size	Item no. 60.74.000
UltraVent recirculating hood - for Size 6-half size, 10-half size electric units only	Item no. 60.67.179
UltraVent Plus recirculating hood - for Size 6-half size, 10-half size electric units only	Item no. 60.76.177
Stands are available in various versions - standard, with casters, or with anchorable stainless steel feet	See Cooking Systems and Accessories catalog
RATIONAL USB stick – to securely transfer cooking programs and HACCP data	Item no. 42.00.162
RATIONAL Single Water Filter - for all single models and Combi-Duo XS/XS, 6-half size/6-half size and 6-half size/10-half size	Item no. 1900.1154US

We offer a wide range of cooking accessories to help you achieve ideal cooking results; for more information, please consult our accessories brochure, ask your dealer, or visit [www.rational-online.com](http://www.rational-online.com)

Planner	RATIONAL AG
	1701 Golf Road, Suite C-120, Commercium Rolling Meadows, IL 60008 Toll Free: 888-320-7274 Fax: 847-755-9583 Email: <a href="mailto:info@rational-online.com">info@rational-online.com</a> Visit us on the internet: <a href="http://www.rational-online.com">www.rational-online.com</a>