

U.S. Range

Summit Series Electric Convection Oven

Project _____
Item _____
Quantity _____
CSI Section 11400
Approved _____
Date _____

Models

- SUME-100
- SUME-200



Model SUME-100

Standard Features

- Solid-State control with electro-mechanic timer
- Two-speed fan control (high/low) with 0.6 HP fan motor
- Total of 10.4 kW loading per oven cavity
- Natural or propane gas
- Stainless steel front, sides, top, and legs
- 60/40 dependent door design with double-pane thermal window in both doors and interior lighting
- Porcelain enameled oven interior with coved corners
- Five chrome-plated oven racks on 13-position rack guides
- Full-length, stainless steel positive door closure
- Double-deck models available, 200 series models
- 1-year limited parts and labor warranty (USA and Canada only)
- 5-year limited door warranty, excluding window (USA and Canada only)

Options & Accessories

- Stainless steel solid doors
- Single window in left-hand door only
- Extra oven racks
- Four swivel casters w/ front brakes
- Four low-profile casters w/ front brakes (double ovens only)
- Open base with rack guides and shelf (stainless steel)
- 460 volt, three-phase
- Back enclosure (stainless steel)
- Removable stainless steel drip pan

Specifications

U.S. Range Summit full-size standard-depth, electric convection oven.

10.4 kW / cavity, 0.6 HP fan motor with two-speed fan speed.

Solid-State control with 60-minute timer.

Porcelain enameled oven interior with coved corners, five oven racks and 13-position rack guides.

All model interiors are 29" (736mm) W by 24" (610mm) H, depth is 24" (610mm)

Stainless steel front, sides, top, and legs.

60/40 dependent door design with double-pane thermal windows, and interior lighting.

200 Models are double-deck units.

Specify voltage if other than 115 volt, 60 Hz, 1 phase.

UL, CUL Classified and NSF Listed.

Note: Ovens supplied with casters must be installed with an approved restraining device.



Summit Series Electric Convection Oven

Garland Commercial Ranges Ltd.
1177 Kamato Road,
Mississauga, Ontario
L4W 1X4 CANADA

General Inquires 1-905-624-0260
USA Sales, Parts and Service 1-800-424-2411
Canadian Sales 1-888-442-7526
Canada or USA Parts/Service 1-800-427-6668

www.garland-group.com
8113A
06/25



U.S. Range

Summit Series Electric Convection Oven

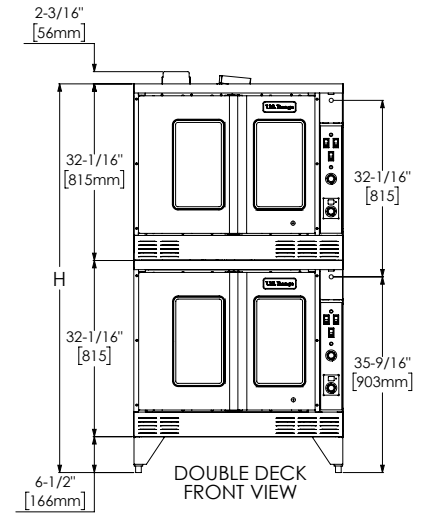
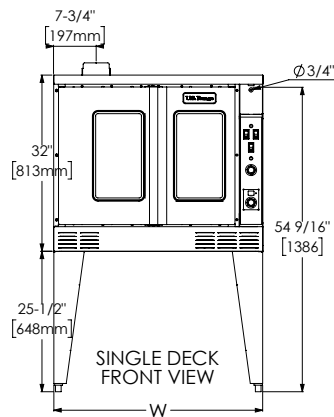
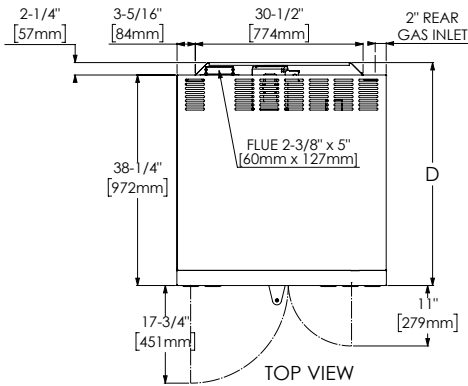

This product is not approved for residential use. Many local codes exist and it is the responsibility of the owner and installer to comply with those codes.

Note: Installation clearance reductions are applicable only where local codes permit.

Model	Int. Dimensions :In (mm)			Ext. Dimensions: In (mm)			Ship Wt	Ship Dim.
	W	H	D	W	H	D (w/motor)	Lbs/kg	Cubic Ft.
SUME-100	29 (736)	24 (610)	24 (610)	38 (965)	57-1/2 (1461)	41-1/4 (1048)	515/230	64
SUME-200	29(736)	24(610)	24(610)	38(965)	70-1/2 (1791)**	41-1/4 (1048)	1030/465	128

** Height with or without with standard casters. Height with low profile casters (double-deck) is 68-1/2" (1740mm).

Model	Tota kW	Nominal Amperes Per Line, (includes 0.6 HP fan motor)										
		208V/1Ph	240V/1Ph	208V/3Ph			240V/3Ph			460V/3Ph		
				X	Y	Z	X	Y	Z	X	Y	Z
Single-Deck	10.4	50	43	30	30	28	26	26	24	14	14	13
Double-Deck* each oven	10.4	50	43	30	30	28	26	26	24	14	14	13

* Double-deck models require individual power supply connections

Installation Notes:			
Combustible & Non-Combustible Wall Clearances:			
Sides	*1" (25mm)	Back	3" (76mm)
*Note: Installations beside units with high heat sources it is recommended to leave 6" (152mm) on the right side of oven. Refer to the installation manual for more detail.			
Entry Clearances: In (mm)			
Crated	47" (1194mm)	Uncrated	32-1/2 (826mm)

Notes:

Electrical specifications include motor requirements. 0.6, HP, 2-speed motor: 1725/1140 rpm, (60Hz). Please specify electrical characteristics when ordering.

Garland/US Range reserves the right to make changes to the design or specifications without prior notice.

Garland Commercial Ranges Ltd.
1177 Kamato Road,
Mississauga, Ontario
L4W 1X4 CANADA

General Inquires 1-905-624-0260
USA Sales, Parts and Service 1-800-424-2411
Canadian Sales 1-888-442-7526
Canada or USA Parts/Service 1-800-427-6668

www.garland-group.com
8113A
06/25

