

Project: \_\_\_\_\_

Item: \_\_\_\_\_

Quantity: \_\_\_\_\_

## Lug Dollies



1265



1261



1266H

These dollies can be used for transporting a high volume of material.

- Ideal for bulk food transporting.
- Accepts standard lugs (16"W x 8½"H x 25"L).
- Heavy Duty Lug Dollies feature an all-welded base, reinforced at the corners with caster plates securely welded in place.
- Single lug dollies are 20" tall, designed to fit nicely under a meat grinder.
- Double lug dollies are designed to be tabletop height.
- NSF Certified.



1262



1263



1264



**New Age Industrial Corp., Inc. || [NewAgeIndustrial.com](http://NewAgeIndustrial.com) || Made in the USA** 

PO Box 520 • 16788 US Hwy 36 • Norton, Kansas 67654 || **Phone: (800) 255-0104 • (785) 877-5121** || Fax: (877)-877-7687 • (785) 877-2616

This information is for general sales and engineering use only. New Age Industrial reserves the right to modify or make changes at any time, without notice, to materials and specifications.

Project: \_\_\_\_\_

Item: \_\_\_\_\_

Quantity: \_\_\_\_\_

## Lug Dollies

### Heavy-Duty Lug Dollies

- Framework is constructed of 1¼" x 1½" x .080" D-Tube.
- Angle runners on the four, six, and ten lug dollies are constructed out of 1¼" x 1¼" x .100" wall angle.
- Equipped with four 5" plate type swivel casters.
- Lifetime Guarantee against rust and corrosion.
- Five-Year Guarantee against workmanship and material defects.
- NSF Certified.

### Standard Lug Dollies

- Framework is constructed out of 1" x 1" x .070" wall tubing.
- Lugs sit on 7⁄8" x 7⁄8" x .070" wall tubing.
- Equipped with four 5" stem type swivel casters.
- Lifetime Guarantee against rust and corrosion.
- Five-Year Guarantee against workmanship and material defects.
- NSF Certified.

### Lug Dollies

Model No.	Width	Size Height	Length	Lug Capacity	Ship Lbs.
<b>Heavy Duty</b> - Accepts 15½" x 8¾" x 25" Lug (Not Included)					
1261	18⅞"	27½"	21"	2	24
1262	18⅞"	52"	26½"	4	36
1263	18⅞"	72"	26½"	6	40
1264	29½"	62"	33"	10	48

#### Model #1261 Requires Stacking Lugs.

#1261, #1262, & #1263 has four 5" plate type swivel casters.

#1264 has four 5" plate type casters; two swivel, two rigid.

**Options:** Options may not be NSF Certified. Contact the factory.

**Caster Locks (2)** - Add "CL" suffix to model #. (#1261, #1262 & #1263 only)

#### Standard - Accepts 15½" x 8¾" x 25" Lug (Not Included)

1265	16¾"	19"	26"	1	11
1266	16¾"	33"	29¼"	2	18
99304*	16¼"	41½"	28½"	3	21

1267 Handle for #1265 & #1266 (bolted on)

#### Standard - With Welded Handle

1265H*	16¾"	36½"	28¾"	1	14
1266H*	16¾"	36½"	30½"	2	17.5

Four 5" stem type casters.

\* Not NSF Certified.

**Options:** Options may not be NSF Certified. Contact the factory.

**Caster Locks (2)** - Add "CL" suffix to model #.

**Medical Caster Upgrade** - Add "MD" suffix to model #.

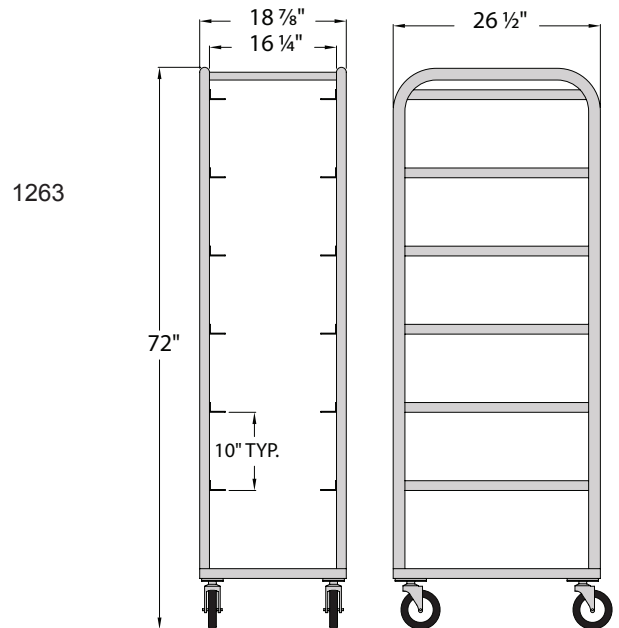

New Age Industrial Corp., Inc. || [NewAgeIndustrial.com](http://NewAgeIndustrial.com) || Made in the USA

PO Box 520 • 16788 US Hwy 36 • Norton, Kansas 67654 || Phone: (800) 255-0104 • (785) 877-5121 || Fax: (877)-877-7687 • (785) 877-2616

This information is for general sales and engineering use only. New Age Industrial reserves the right to modify or make changes at any time, without notice, to materials and specifications.