



DIRECT STEAM QUAD LEG KETTLE

Job

Item#



MODEL	CAPACITY	
DL-125	125 Gallon	473 Liter
DL-150	150 Gallon	568 Liter

SPECIFICATIONS:

Shall be a Crown Model _____, direct steam connected quad leg kettle. A double wall kettle interior shall form a steam jacket around lower 2/3 of the kettle. The bottom of the kettle shall be of hemispherical design for superior heat circulation. Kettle shall be mounted on four stainless steel tubular legs. Each leg shall be fitted with a 4 hole adjustable flanged foot for securing to the floor. Construction shall be all welded satin finish stainless steel type 304. The kettle interior shall be stainless steel type 316. Convenience features shall include a 2" (50 mm) sanitary draw-off valve with perforated strainer, a hinged flat split stainless steel cover.

OPERATION SHALL BE BY:

Direct steam at a minimum of 5 PSI (34 kPa) and a maximum of 20 PSI (137 kPa).

OPTIONAL ITEMS AT EXTRA COST:

- 35 psi (241 kPa) high pressure operation for higher cooking temperature (HP-35)
- 3" (76 mm) draw-off valve with perforated strainer (TVS-3)
- Etched gallon markings (GM-)
- Etched litre markings (LM-)
- Correctional package

ACCESSORIES:

- Triple basket assembly (TBA-)
- Solid disc for draw-off valve (TSS-)
- Strainer hook (SH)
- Graduated measuring strip (CMS-)
- Steam trap assembly, consisting of steam trap, steam control valve, line strainer, check valve,(STA-1)
- Single pantry kettle filler (SP-KF)
- Double pantry kettle filler (DP-KF)
- Single pantry faucet with swing spout (SF-12)
- Double pantry faucet with swing spout (DF-12)



Models: DL-125 DL-150

MODEL	SHIPPING WEIGHT	MINIMUM CLEARANCE	
		DL-125	425 lbs. [193 kg]
DL-150	465 lbs. [211 kg]	BACK	.5 [13]

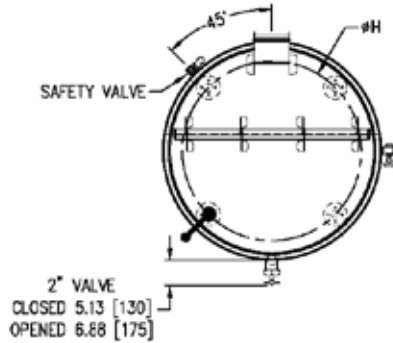

FLANGED FOOT DETAIL
 4 EQUALLY SPACED
 7/16" [11mm] DIA. HOLES
 ON 2.835" [72mm] B.C.

NOTE:
 DIMENSIONS E AND F ARE BASED
 ON #2" DRAW OFF VALVE

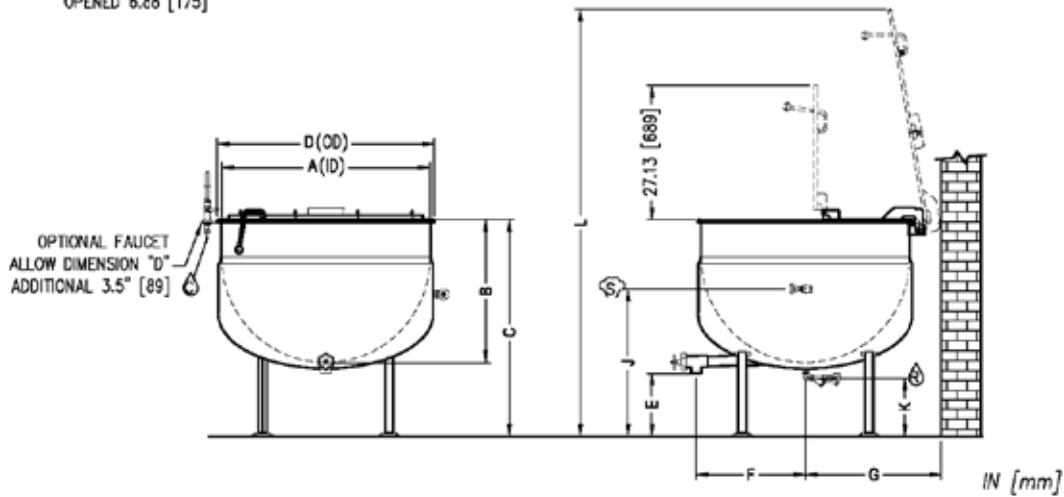

DIMENSIONS

MODEL	CAPACITY	UNITS	A	B	C	D	E	F	G	H	J	K	L
DL-125	125 gallons (473 liters)	in (mm)	42" (1067)	28.75" (730)	43.75" (1111)	44" (1118)	12.43" (316)	22" (559)	27.5" (699)	36.12" (918)	29.88" (759)	12.0" (305)	86.38" (21.94)
DL-150	150 gallons (568 liters)	in (mm)	42" (1067)	33" (838)	48" (1219)	44" (1118)	12.43" (316)	22" (559)	27.5" (699)	36.12" (918)	29.88" (759)	12.0" (305)	90.5" (2299)

SERVICE CONNECTIONS

- STEAM SUPPLY: 3/4" IPS (19 mm) 5-20 PSI (34-137 kPa). Optional 5-30 PSI (34-206 kPa).
- COLD WATER: 3/8" O.D. tubing to kettle fill faucet (OPTIONAL)
- CONDENSATE RETURN: 1/2" IPS (13 mm)

**INTENDED FOR COMMERCIAL USE ONLY.
 NOT FOR HOUSEHOLD USE.**



70 Oakdale Road, Toronto ON, Canada M3N 1V9
 (919) 762-1000 www.crownsteamgroup.com