

BLACK DIAMOND®

Project Name: _____

Location: _____

Item #: _____

Qty: _____

Black Diamond Undercounter Freezer, Double Solid Doors, 15.7 cu ft, in Stainless Steel

GRUCFZ-60



Elevate your commercial kitchen with the Black Diamond Undercounter Freezer. This double solid door freezer boasts a spacious 15.7 cu. ft. capacity and durable stainless steel construction, making it ideal for restaurants, cafes, bakeries, and bars. An efficient rear-mounted compressor and electronic controls help maintain temperatures from -8° to 0°F, preserving food quality. The eco-friendly R290 system and easy-to-clean surfaces combine reliability with simple maintenance. Backed by a two-year parts and labor warranty and a five-year compressor warranty.

FEATURES AND CONSTRUCTION

- Offers 15.7 cu ft of frozen storage capacity, maximizing space for commercial kitchens
- Equipped with a 1/5 horsepower rear-mounted compressor for efficient and reliable cooling
- Constructed with a stainless steel exterior and painted aluminum interior for durability and easy maintenance
- Maintains a temperature range of -8° to 0°F for optimal frozen food storage
- Utilizes eco-friendly R290 refrigerant
- Uses a standard NEMA 5-15P plug
- Includes two adjustable wire shelves for flexible product organization
- Equipped with four heavy-duty casters for smooth mobility in any commercial setting
- Features a user-friendly automatic controller for precise temperature

ELECTRIC

115VV / 60Hz / 1Ph

Cord Length (Inches): 98.40"

Plug Type: NEMA 5-15P

Cord set included

NEMA 5-15P



3RD PARTY APPROVALS



WARRANTY (USA / CANADA)

Two (2) Year Limited Warranty on Parts and Labor, Five (5) Year Warranty on Compressor and Evaporator

Contact us for details at 1.877.368.2797



STORAGE CAPACITY

- Cubic Feet: 15.7 cu. ft.

TEMPERATURE

- Holding Temperature (Fahrenheit): -8° - 0°

These models are designed to operate in an environment where temperature and humidity do not exceed 75°F (24°C) and 55% relative humidity



Black Diamond Undercounter Freezer

GRUCFZ-60

FRONT

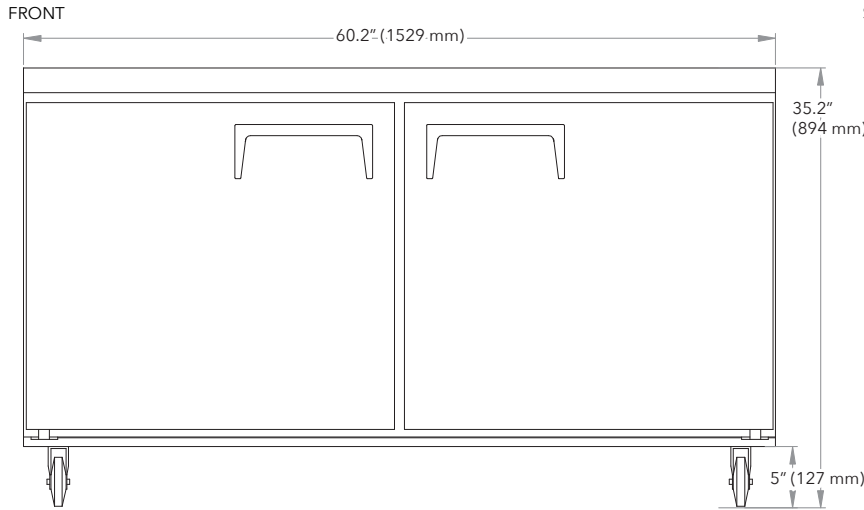

SIDE

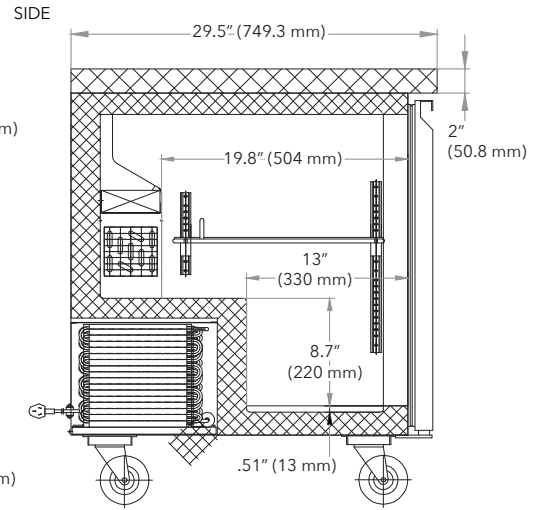

TOP

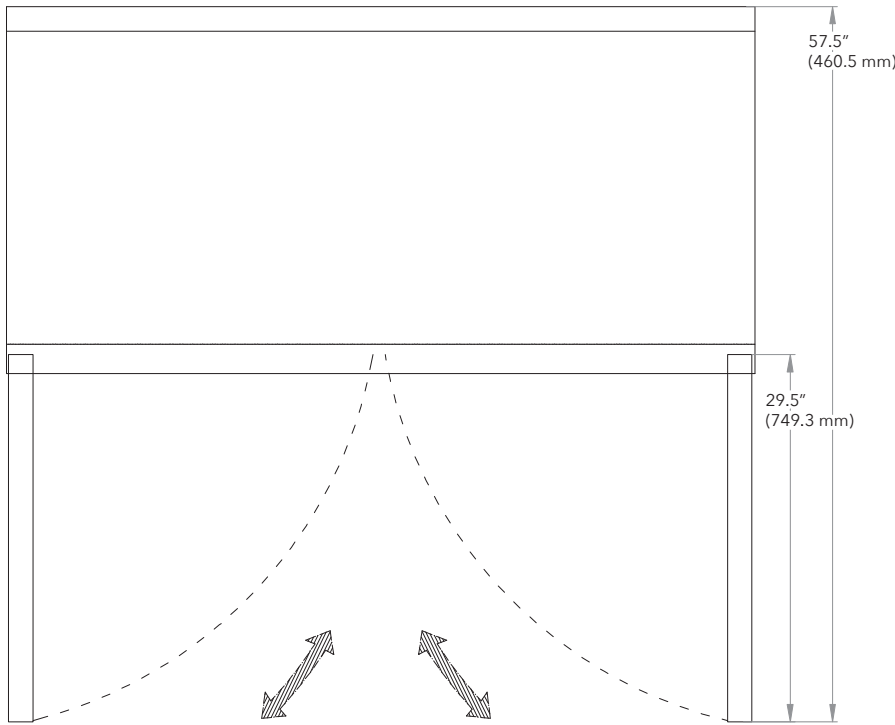

TOP

Undercounter

Doors	Shelves	Amps	HP	Refrigerant	Assembled Dimensions (in)	Item Weight (lbs)	Shipping Weight (lbs)
2	2	4.5A	1/5	R290	29.50" x 60.20" x 35.20"	253.6	323.0

Due to periodic changes in designs, methods, procedures, policies and regulations, the specifications contained in this document are subject to change without notice. While we exercise good faith efforts to provide information that is accurate, we are not responsible for errors or omissions in information provided or conclusions reached as a result of using the specifications. By using the information provided, the user assumes all risks in connection with such use.