

# Platinum

### Standard Features

- 32" wide sectional range with 25-3/4" width plancha griddle available with a standard-oven base, convection-oven base, cabinet base or as a modular unit (for mounting on countertop, refrigerated or freezer base)
- Three 16,000 BTU NAT (15,500 BTU LP) cast iron burners with three manual control knobs
- Battery spark ignition
- 1/2" thick reinforced griddle plate
- Side and rear splashers
- 5" deep front rail
- Increased capacity removable stainless steel grease drawer
- Stainless steel front, sides, rear and exterior bottom
- Fully insulated lining and burner box
- 1-1/4" front gas manifold and 1" rear gas connection
- 5" high stainless steel flue riser
- Free battery-design assistance
- (1) year limited parts and labor warranty (reference <http://www.southbendnc.com/service.html> for limited warranty details).

### Standard Features of Oven-Base Models

- 45,000 BTU NAT (45,000 BTU LP) oven with standing pilot
- Heavy duty, stainless steel door handle
- Porcelain enamel interior
- Oven racks (2 for standard oven, 3 for convection oven)
- "Insta-On" thermostat ranging from 175°F to 550°F
- Standard-oven interior is large enough (26" by 26-1/2") for sheet pans to fit either way
- Convection-oven models have 1/2 hp, two-speed blower

### Standard Features of Cabinet-Base Models

- Stainless steel cabinet with removable doors that open from the center

- P32N-PPP (Modular Mount with Plancha Griddle)
- P32C-PPP (Cabinet Base with Plancha Griddle)
- P32D-PPP (Standard-Oven Base with Plancha Griddle)
- P32A-PPP (Convection-Oven Base with Plancha Griddle)

### \*\* PLANCHA UNITS DO NOT ALLOW SPECIFIC TEMPERATURE OPERATION \*\*

Plancha units have a raised griddle plate for easy cleaning of cooking surface between loads. 3" wide collection on sides allow separation of waste for preparation of next fare. Plancha griddle is 1/2" thick reinforced steel plate powered by cast iron burners provides fast preheat and recovery time. High heat zone with max temperatures of 800°F located on front 2/3 of plate for quick sear with decreased temps on rear 1/3 of plate for product finishing.



Model Shown P32N-PPP

### STANDARD CONSTRUCTION SPECIFICATIONS

**Exterior Finish:** Front, sides, rear and exterior bottom constructed of #3 polished 430 and 304 stainless steel.

**Range:** 32"-wide front-manifold sectional range with 25-3/4" width 48,000 BTU NAT (46,500 BTU LP) plancha griddle with side and rear splashers and grease drawer.

**Front Rail:** 5" deep front rail.

**Flue Riser** 5" high stainless steel flue riser

**Battery:** Unit can be in any position in a battery.

**Legs:** 6" stainless steel adjustable legs standard.

**Model 32D:** 45,000 BTU NAT (45,000 BTU LP) oven with standing pilot and thermostat range of 175°F to 550°F (79°C to 288°C). Porcelain enamel interior, measuring 14" high x 26" wide x 26.5" deep. Two racks with five-position side rails.

**Model 32A:** 45,000 BTU NAT (45,000 BTU LP) convection oven with standing pilot and thermostat range of 175°F to 550°F (79°C to 288°C). Porcelain enamel interior, measuring 14" high x 26" wide x 24" deep. Three racks with five-position side rails. Two-speed, 1/2 hp blower motor.

**Model 32C:** Stainless steel cabinet base with two removable doors that open from the center.

Job  
Item#

Models:

P32N-PPP

P32C-PPP

P32D-PPP

P32A-PPP

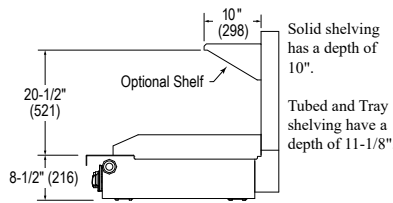
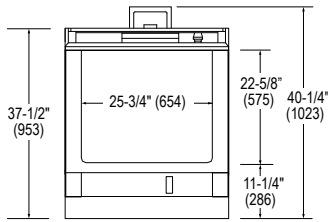

SIDE VIEW OF MODULAR MODEL

SHIPPING CRATE DIMENSIONS & WEIGHT					
MODEL	WIDTH	HEIGHT	DEPTH	VOLUME	WEIGHT
P32N-PPP	39\"/>				

Dimensions shown in inches and (millimeters)

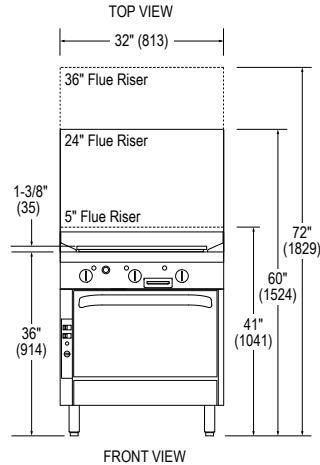

FRONT VIEW

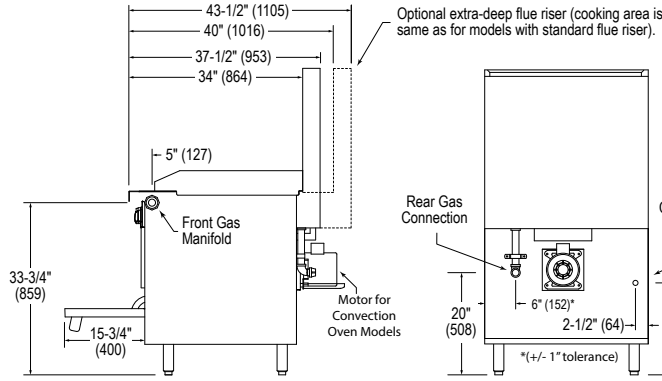

SIDE VIEW

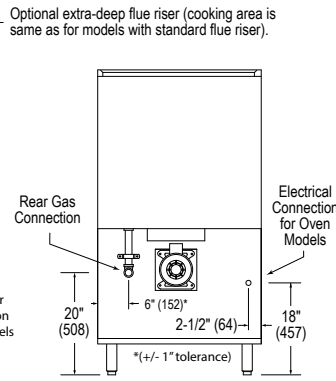

REAR VIEW

**UTILITY INFORMATION**

**GAS:** Each unit has a 1-1/4" front manifold that couples to the adjacent sectional unit(s), and a 1" rear gas connection with a male NPT connector. Minimum gas supply pressure is 7" W.C. for natural gas and 11" W.C. for propane.

MODEL	GAS (BTU/HOUR)		ELECTRICITY (AMPS)	
	NATURAL	PROPANE	120V	208/240V
P32N-PPP	48,000	46,500	-	-
P32C-PPP	48,000	46,500	-	-
P32D-PPP	93,000	91,500	0*	0*
P32A-PPP	93,000	91,500	5.9*	2.7*

\*Standing Oven Pilot Models

All sectional units require a regulated gas supply (a pressure regulator must be ordered separately). If using a flexible-hose gas connection, the inside diameter of the hose must not be smaller than the connector on the unit and must comply with ANSI Z21.69, providing an adequate means of restraint to prevent undue strain on the gas connection.

**ELECTRICITY:** Convection oven models with optional electronic ignition require 50Hz or 60Hz single-phase power. 120V models have a 7-foot power cord with ground plug (5.9A for "A" models). 208/240V models have a terminal block for connection to a single-phase 208/240V source (2.7A for "A" models).

**MISCELLANEOUS**

- If casters are used with a flexible-hose gas connection, a restraining device should be used to prevent undue strain on the hose.
- Minimum clearance from noncombustible construction is zero (except there must be 2" clearance behind the blower motor of convection-oven models). Minimum clearance from combustible construction is 10" (254 mm) on sides and 12" (305 mm) on rear.
- Installation under a vented hood is recommended.
- Check local codes for fire and sanitary regulations.

**NOTICE:** Southbend has a policy of continuous product research and improvement. We reserve the right to change specifications and product design without notice. Such revisions do not entitle the buyer to corresponding changes, improvements, additions or replacements for previously purchased equipment.

**OPTIONS and ACCESSORIES**

- External pressure regulator
- Cable restraint kit (to restrict movement when on casters)
- Extra-deep rear-extending flue riser
- Front rail options:
  - Cutouts in front rail for sauce pans
  - 7-1/4" deep front rail (to match old style sectional)
  - Square belly bar mounted on 7-1/4" deep front rail
- 24" or 36" high flue riser
- Stainless steel oven interior
- Shelves on flue riser (one on 24" flue riser, one or two on 36" flue riser, 10" deep)
- Salamander or cheesemelter mounted on 36" flue riser
- Tray or tubular shelving (12" deep)
- Removable shelf inside cabinet
- Open-frame base with casters for battery
- Electronic oven pilot ignition (no charge)

**INTENDED FOR COMMERCIAL USE ONLY.  
NOT FOR HOUSEHOLD USE.**



1100 Old Honeycutt Road, Fuquay-Varina, NC 27526  
(919) 762-1000 www.southbendnc.com