

SANDWICH UNIT REFRIGERATOR

Model: SW32N8-FB

Natural Refrigerant R-290 Model

32" Standard Top Sandwich Unit Refrigerator with Solid Door - 8 Pans Front Breathing

Stainless steel front, top and end panels, aluminum back and interior.



Options and Accessories

(upcharge and lead times may apply)

| | |
|---------------------------------------|----------------------------|
| Stainless steel interior | Flat lid |
| Stainless steel back | Vision panel lid |
| Additional epoxy coated steel shelves | Rear mounted cutting board |
| Stainless steel shelves | Composite cutting board |
| Overshelves (single or double) | Crumb catcher |
| Door locks | Modified pan opening |
| Drawers in lieu of door* | |

Consult factory for other model configurations, options and accessories.

*Drawers hold (1) 12x20x6 pan OR (1) 1/2 & (2) 1/3 pans per drawer

Continental
Refrigerator



Project Name:

Model Specified:

Location:

Item No:

Quantity:

AIA #:

SIS #:

Standard Model Features

REFRIGERATION SYSTEM

Performance rated refrigeration system

Natural, environmentally safe, high efficiency R-290 refrigerant¹

Unique air flow distribution allows pan product to maintain 33° - 41°F

Automatic, hot gas condensate evaporator

Non-corrosive, plasticized fin evaporator coil

Easily serviceable, back mounted compressor

CABINET ARCHITECTURE

2" non-CFC polyurethane foam insulation

Smooth, polished chrome door handle

Spring loaded, self closing door

Magnetic snap in Santoprene™ door gasket

Heavy duty, epoxy coated steel shelf

12" deep, full length nylon cutting board

Insulated lid

Completely enclosed, vented and removable case back

3 3/4" casters

MODEL FEATURES

(8) 1/6 size recessed pans, 4" deep

Removable interior tub below pans

Electronic control, off-cycle defrost

Field rehingeable door

¹ R-290 refrigerant meets all federal and state regulatory requirements.

Front breathers are a unique, field assembled, bottom mounted ventilation system designed to allow cabinets to be flush against a wall or built into a counter to conserve space. For proper operation, the area under and in front of the cabinet must not be obstructed in any way.

APPROVAL:

Model Specifications

DIMENSIONAL DATA

| | |
|---|------------------|
| Net Capacity (cubic feet) | 9.0 (253 l) |
| 1/6 Size Pans (4" deep) | 8 |
| Width, Overall (inches) | 32 (813 mm) |
| Depth, Overall (inches) (including handle & bumpers) | 32 3/16 (818 mm) |
| Depth, Cutting Board (inches) | 12 (305 mm) |
| Height, Overall (inches) (including 3 3/4" casters) | 41 (1041 mm) |
| Shelf Area (square feet) | 3.9 (0.4 sq m) |
| Number of Shelves | 1 |
| Number of Doors | 1 |
| Interior Depth (inches) | See Drawing |
| Interior Height (inches) | 26 1/4 (667 mm) |
| Interior Width (inches) | 28 (711 mm) |

REFRIGERANT DATA

| | |
|-------------------------------|------|
| Condensing Unit Size (H.P.) | 1/5 |
| R-290 Refrigerant Charge (oz) | 3.4 |
| Capacity (BTU per hour)* | 1390 |

ELECTRICAL DATA

| | |
|--|---------------------|
| Voltage (International) | 115/60/1 (220/50/1) |
| Total Amps (International) | 3.1 (1.6) |
| 10 ft. Cord/Plug [attached] (International) | Yes (No) |

SHIPPING DATA

| | |
|--------------------------|------------------|
| Weight (pounds) | 275 (125 kg) |
| Height - Crated (inches) | 43 1/4 (1099 mm) |
| Width - Crated (inches) | 40 (1016 mm) |
| Depth - Crated (inches) | 37 1/4 (946 mm) |

* Rating @ +25°F evaporator, 90°F ambient
 Figures in parentheses reflect metric equivalents rounded to the nearest whole unit.



Equipped with one NEMA-5-15P Plug
 (varies by country)

Continental[®]

Refrigerator

Toll-Free: 800-523-7138
 Phone: 215-244-1400
 Fax: 215-244-9579

539 Dunksferry Road
 Bensalem, PA 19020
www.continentalrefrigerator.com

Due to our continued efforts in developing innovative products, specifications subject to change without notice.



PROUDLY
 DESIGNED & ASSEMBLED
 IN THE U.S.A.

© Copyright 2021. Continental Refrigerator.
 A Division of National Refrigeration & Air Conditioning Products, Inc.

Model Plan Views

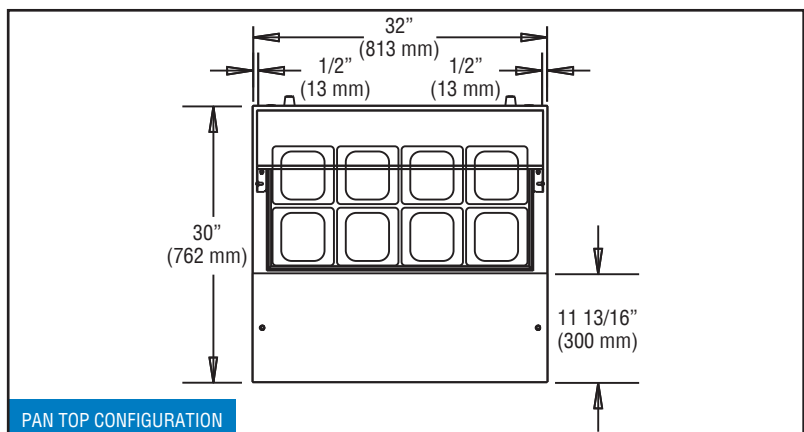
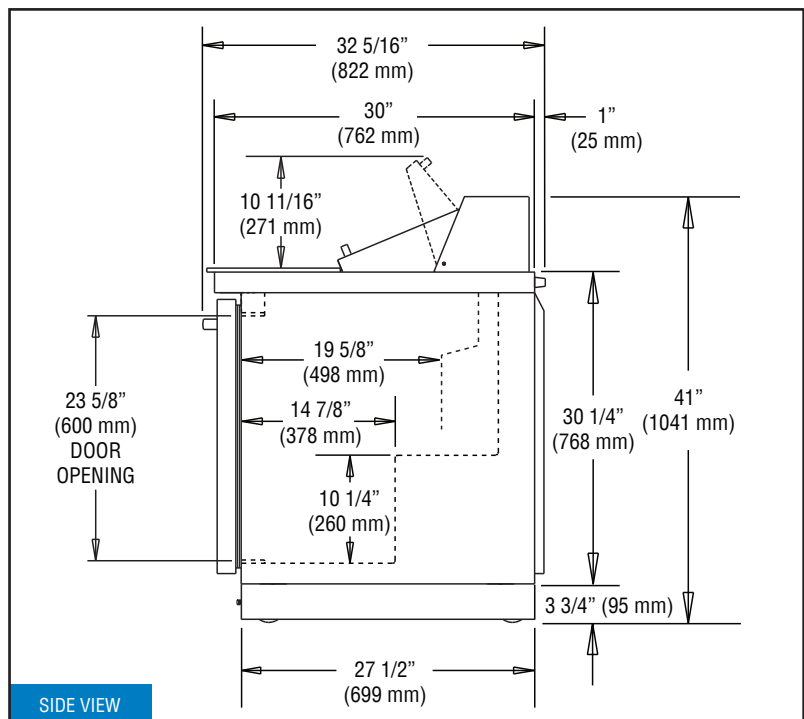
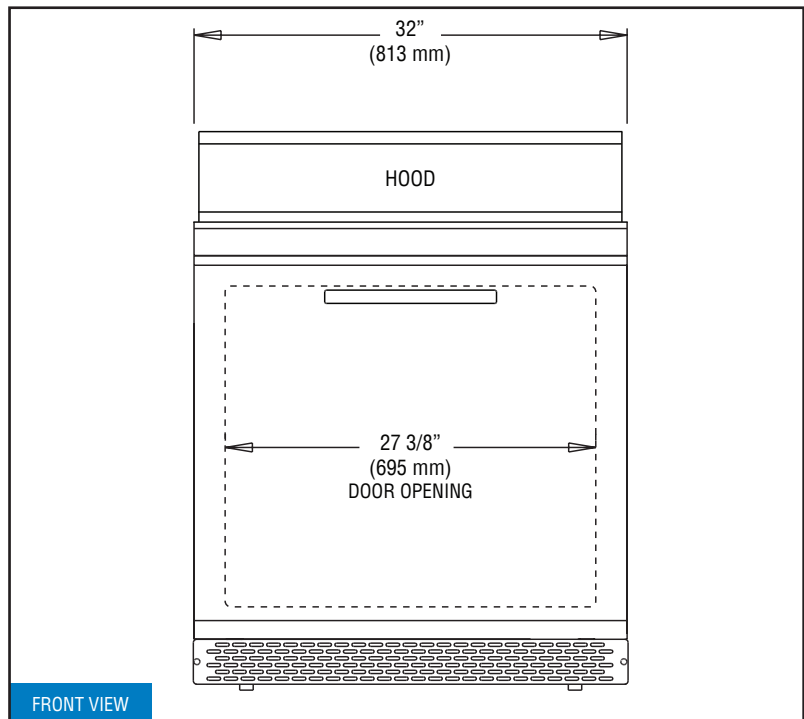

REVISED: 12/4/25