

SEAGATE

SANDWICH PREP SANDWICH PREPARATION TABLES

SEAGATE refrigerated counter/prep tables were designed to deliver quality and performance for fast efficient prepping at an affordable price.

Fruits, vegetables and deli foods stay fresh until you're ready to serve thanks to the robust refrigeration system that keeps temperatures cold and consistent.

All units are equipped with one shelf per door, an 11.4" deep cutting board, a digital display for temperatures, and a stainless steel exterior & interior with four 2.5" casters.

The solid hinged door(s) are self-closing and stay open at 90° for easy restocking. The easy-to-clean stainless steel interior and exterior also have anti-corrosive properties that make maintenance easier too.

SEAGATE, it means a great deal.



1, 2, & 3 DOOR
MODELS AVAILABLE

STANDARD FEATURES

- Electronic thermostat and an easy-to-read digital LED temperature display for optimal accuracy
- 90 degree hold open door for easier stocking
- 11.4" deep cutting board included
- One adjustable heavy-duty, epoxy coated wire shelf per door
- Easy to mount 2.5" casters with two lockable front casters
- All stainless steel exterior & interior
- CFC free refrigerant and foam insulation
- Auto defrosting and auto evaporation of condensation water
- Magnetic gasket can be replaced without any tools

AVAILABLE EXCLUSIVELY AT BURKETT RESTAURANT EQUIPMENT & SUPPLIES | BURKETT.COM/BRAND/SEAGATE | 419-720-8190

SEAGATE

WARRANTY
PROTECTION PLAN

2-YR PARTS & LABOR WARRANTY
5 YEAR COMPRESSOR WARRANTY



SSP29



SSP48



SSP72



BIG TOP MODELS:

SSP29M



SSP72M

SPECIFICATIONS

MODEL NUMBER	SSP29	SSP29M	SSP48	SSP72	SSP72M
DOORS	1	1	2	3	3
NUM. OF 1/6 SIZE PANS	8	12	12	18	18
CU/FT	5.2	5.2	8.8	13.1	13.1
SHELVES	1	1	2	3	3
H/P	1/3	1/3	1/2	1/2	1/2
AMPS	3	3	4.3	4.3	4.3
VOLTAGE	115/60/1	115/60/1	115/60/1	115/60/1	115/60/1
WEIGHT	225	225	322	408	408
ENERGY CONSUMPTION (Kwh/24hr)	8.28	8.28	11.868	11.868	11.868
ENERGY CONSUMPTION (Kwh/6hr)	2.07	2.07	2.967	2.967	2.967
EXTERIOR DIMENSIONS (W x D x H)	28.9" x 29.9" x 43.2"	28.9" x 34.5" x 43.2"	48.2" x 29.9" x 43.2"	71.7" x 29.9" x 43.2"	71.7" x 34.5" x 43.2"
TEMPERATURE RANGE	33°F to 40°F	33°F to 40°F	33°F to 40°F	33°F to 40°F	33°F to 40°F
PLUG TYPE	NEMA 5-15P	NEMA 5-15P	NEMA 5-15P	NEMA 5-15P	NEMA 5-15P

Specifications are subject to change without notice.

AVAILABLE EXCLUSIVELY AT BURKETT RESTAURANT EQUIPMENT & SUPPLIES | BURKETT.COM/BRAND/SEAGATE | 419-720-8190



SEAGATE

TECHNICAL DRAWINGS

SSP29
FRONT

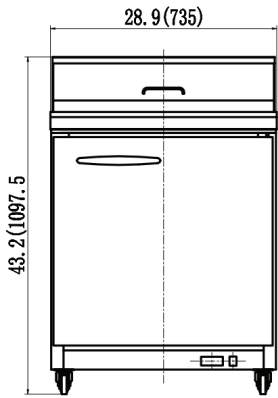

SSP48
FRONT

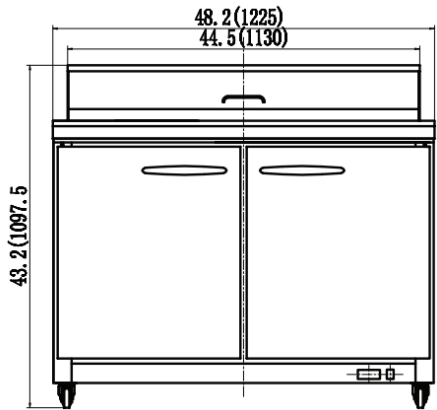

SSP72
FRONT

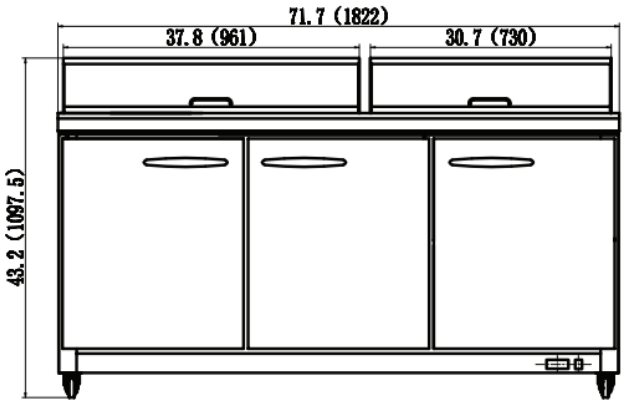

SSP29
TOP

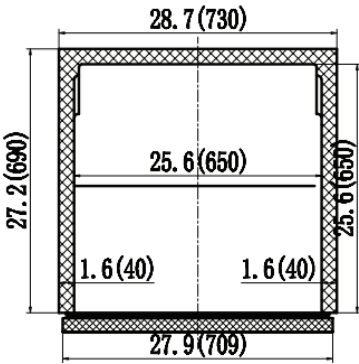

SSP48
TOP

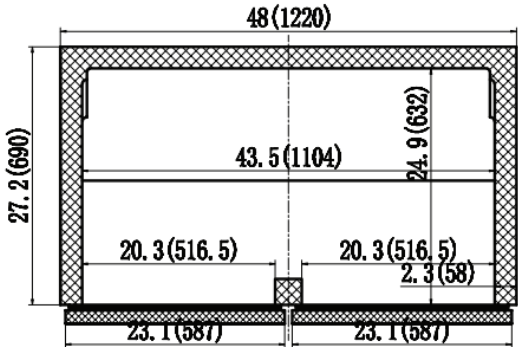

SSP72
TOP

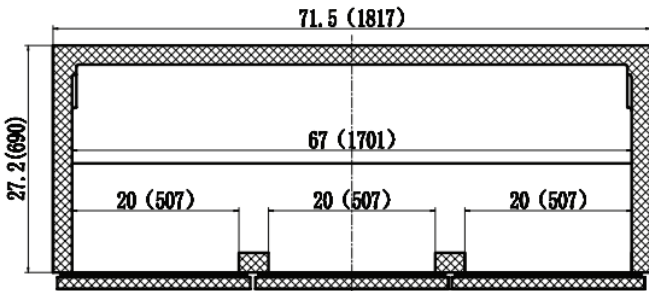

SSP29
TOP

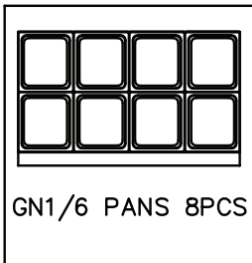

SSP48
TOP

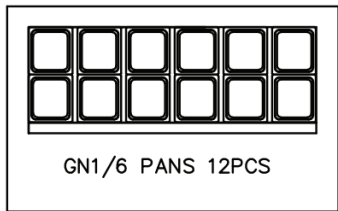

SSP72
TOP

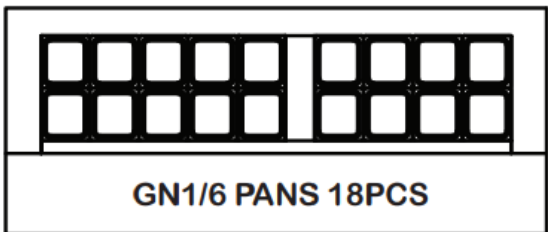

1,2,3 DOOR
SIDE

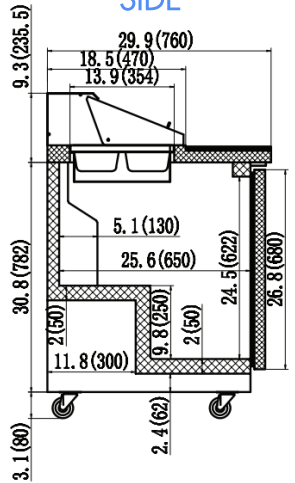

AVAILABLE EXCLUSIVELY AT BURKETT RESTAURANT EQUIPMENT & SUPPLIES | BURKETT.COM/BRAND/SEAGATE | 419-720-8190



SEAGATE

TECHNICAL DRAWINGS

SSP29M

FRONT

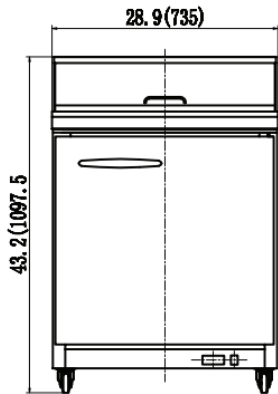

SSP72M

FRONT

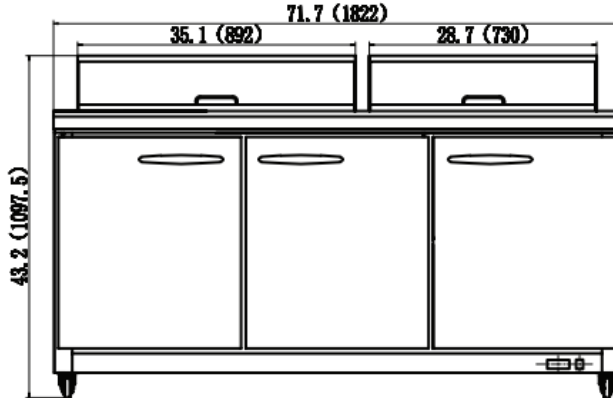

SSP29M

TOP

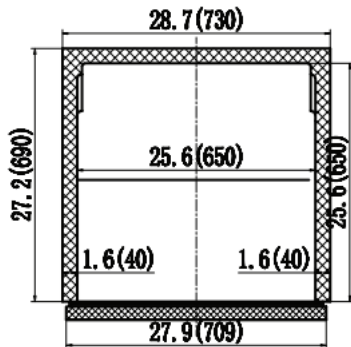

SSP72M

TOP

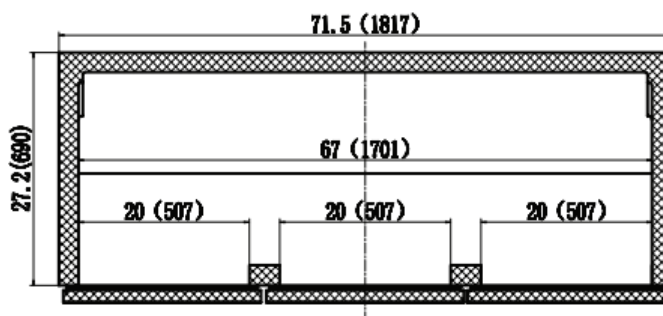

SSP29M

TOP

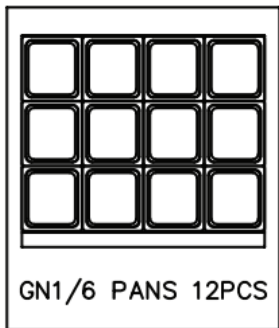

SSP72M

TOP

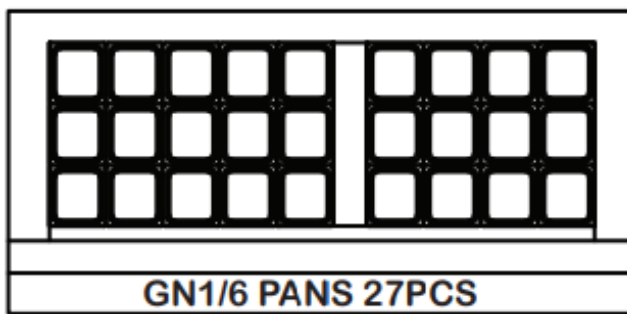

1, 3 DOOR

SIDE

