



TOP SHELF CORNER DRAINBOARDS
TS & TSF Series Inside & Outside Corner Drainboards



JOB	
AREA	
ITEM NO.	
MODEL NO.	



TS45D-FI



TS45D-FO

MODELS	
Inside Corners	
TS SERIES	TSF SERIES
TS45D-FI	TSF45D-FI

Outside Corners	
TS SERIES	TSF SERIES
TS45D-FO	TSF45D-FO

KEY PRODUCT FEATURES AND BENEFITS

- Drainboard tops have drain lines indented towards the drain so water is evacuated quickly and effectively, with the matching insert you get a flat, level space to store your glassware.
- The default option of 'stadium' shaped perforated inserts enable great air flow for efficient glassware drying, maximize glass storage, and are designed to hold up to a busy bar environment abuse.
- Our new, more robust Perlick Quick Clamp leg attachment still features easy tool-less installation.
- All stainless construction with 18 gauge seamless stainless steel front apron for durability and cleanability.
- All Perlick drainboards are NSF-certified, so you can feel confident knowing your equipment will meet health code standards.

Additional Features:

- Optional Perlick Flex Mount leg relocation kit moves rear legs forward for additional space behind the equipment or moves forward legs rearward to help avoid pesky floor drains, available on TSF units.
- Stainless steel legs with adjustable thermoplastic feet install without tools, option on several units.

MODEL NUMBERS - TS45D-FI, TSF45D-FI, TS45D-FO, TSF45D-FO



TOP SHELF CORNER DRAINBOARDS
TS & TSF Series Inside & Outside Corner Drainboards

MODEL NUMBERS - TS45D-FI, TSF45D-FI, TS45D-FO, TSF45D-FO

INSIDE CORNERS

MODEL NOS.		TS45D-FI	TSF45D-FI
DESCRIPTION	Corner Angle	45° Full Corner	
	Depth in. (mm)	18-9/16" (471)	24" (610)
	Weight lb. (kg)	45 (20)	
MATERIALS	Construction	All stainless steel	
	Front & Back	Seamless 18 gauge stainless steel	
	Backsplash	6" or 4" high stainless steel with 1" return, fastened and sealed.	
	Drainboard	Pitched stainless steel drainboard top, All horizontal and vertical edges 1/4" radius with balled corners.	
	Legs	Optional	
MECHANICALS	Plumbing	Stainless steel drain socket located back center of the equipment. Drain connection is 1-1/2" NPS male.	

OUTSIDE CORNERS

MODEL NOS.		TS45D-FO	TSF45D-FO
DESCRIPTION	Corner Angle	45° Full Corner	
	Depth in. (mm)	18-9/16" (471)	24" (610)
	Weight lb. (kg)	45 (20)	
MATERIALS	Construction	All stainless steel	
	Front & Back	Seamless 18 gauge stainless steel	
	Backsplash	6" or 4" high stainless steel with 1" return, fastened and sealed.	
	Drainboard	Pitched stainless steel drainboard top, All horizontal and vertical edges 1/4" radius with balled corners.	
	Legs	Optional	
MECHANICALS	Plumbing	Stainless steel drain socket located back center of the equipment. Drain connection is 1-1/2" NPS male.	



TOP SHELF CORNER DRAINBOARDS
TS & TSF Series Inside & Outside Corner Drainboards

MODEL NUMBERS - TS45D-FI, TSF45D-FI, TS45D-FO, TSF45D-FO

TS45D-FO

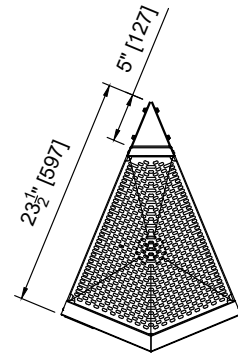
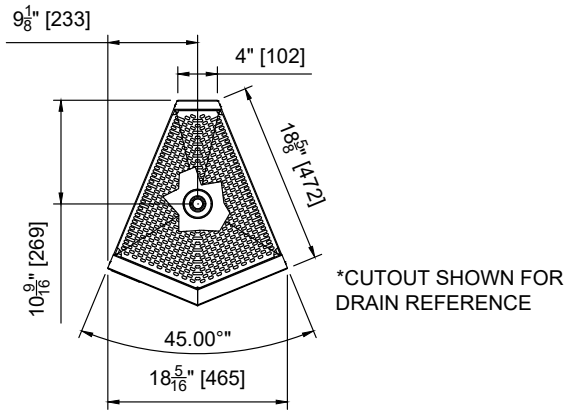

TSF45D-FI

