

# FORCED AIR MILK COOLERS

## Model: MC4ND

Natural Refrigerant R-290 Model

### 49" Forced Air Milk Cooler Dual Access



ENERGY STAR® Qualified Commercial Refrigerator

White painted steel exterior, stainless steel top and door, heavy-duty stainless steel lid(s), door hinges and latches, galvanized steel interior with reinforced stainless steel floor. **Designed to keep milk cold during serving.**



## Options and Accessories

(upcharge and lead times may apply)

|                          |                       |
|--------------------------|-----------------------|
| Stainless steel exterior | Floor foot pedal lock |
| Stainless steel interior | Color laminate        |
| Wrap around bumpers      | Corner bumpers        |

Consult factory for other model configurations, options and accessories.



Project Name:

Model Specified:

Location:

Item No:

Quantity:

AIA #:

SIS #:

## Standard Model Features

### REFRIGERATION SYSTEM

Forced air, performance rated refrigeration system

Natural, environmentally safe, high efficiency R-290 refrigerant<sup>1</sup>

Built-in, electric condensate evaporator

Easily serviceable, bottom mounted condensing unit

### CABINET ARCHITECTURE

2" high density, non-CFC polyurethane foamed-in-place insulation

Snap in lids and door gaskets

Non-corrosive, heavy duty, epoxy coated steel wire floor racks

Cylinder keyed security locks

5" diameter swivel plate casters with front locking brakes

### MODEL FEATURES

Electronic controller with digital display & hi-low alarm

Floor drain

Unique forced air flow curtain

<sup>1</sup> R-290 refrigerant meets all federal and state regulatory requirements.

APPROVAL:

# Model Specifications

## DIMENSIONAL DATA

|  |              |
|--|--------------|
| Net Capacity (cubic feet)                          | 20.0 (566 l) |
| Crate Capacity (13" x 13" x 11")                   | 12           |
| Crate Capacity (19" x 13" x 11")                   | 8            |
| Width, Overall (inches)                            | 49 (1245 mm) |
| Depth, Overall (inches)                            | 33 (838 mm)  |
| Height, Overall (inches)<br>(including 5" casters) | 47 (1194 mm) |

## REFRIGERANT DATA

|                               |      |
|-------------------------------|------|
| Condensing Unit Size (H.P.)   | 1/3  |
| R-290 Refrigerant Charge (oz) | 4.3  |
| Capacity (BTU per hour)*      | 2540 |

## ELECTRICAL DATA

|  |                     |
|--|---------------------|
| Voltage (International)                        | 115/60/1 (220/50/1) |
| Total Amps (International)                     | 5.0 (2.5)           |
| 10 ft. Cord/Plug [attached]<br>(International) | Yes<br>(No)         |

## SHIPPING DATA

|                          |              |
|--------------------------|--------------|
| Weight (pounds)          | 470 (213 kg) |
| Height - Crated (inches) | 56 (1429 mm) |
| Width - Crated (inches)  | 58 (1480 mm) |
| Depth - Crated (inches)  | 37 (927 mm)  |

\* Rating @ +25°F evaporator, 90°F ambient  
Figures in parentheses reflect metric equivalents rounded to the nearest whole unit.



Equipped with one NEMA-5-15P Plug  
(varies by country)

# Model Plan Views

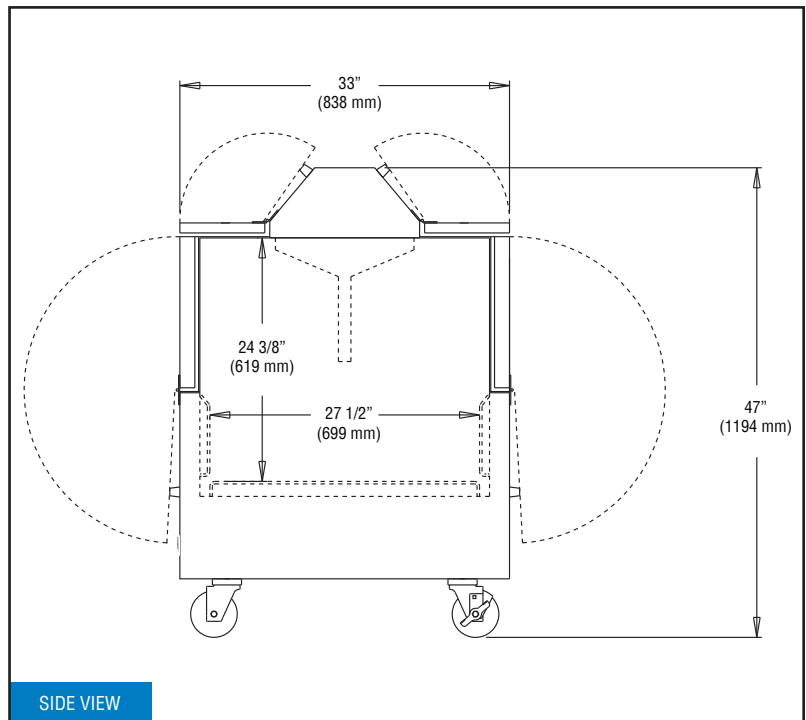
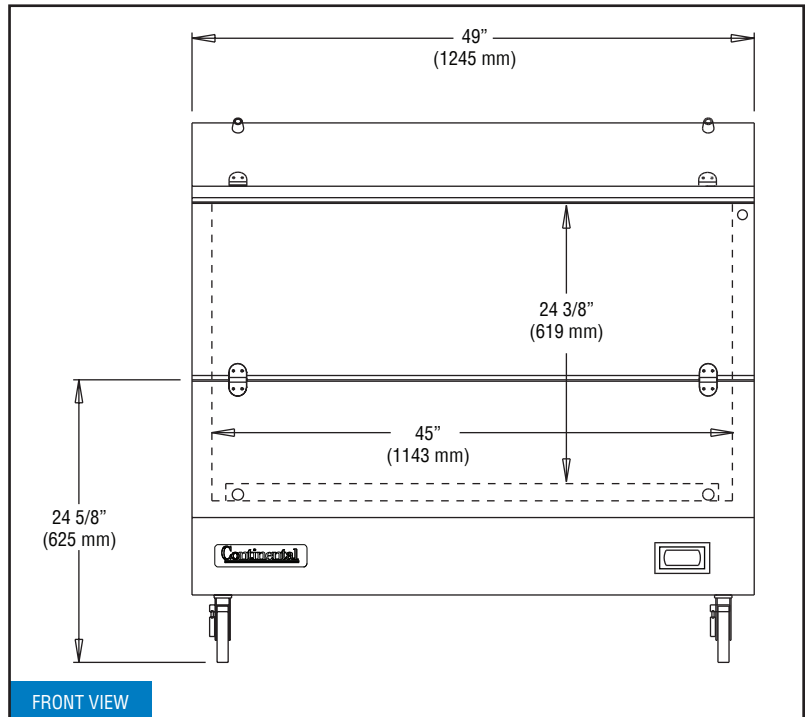

**Continental**  
Refrigerator

Toll-Free: 800-523-7138  
Phone: 215-244-1400  
Fax: 215-244-9579

539 Dunksferry Road  
Bensalem, PA 19020  
[www.continentalrefrigerator.com](http://www.continentalrefrigerator.com)

Due to our continued efforts in developing innovative products, specifications subject to change without notice.



PROUDLY  
DESIGNED & ASSEMBLED  
IN THE U.S.A.