

# TURBOJET II COOK CHILL TANK

Project \_\_\_\_\_  
 Item \_\_\_\_\_  
 Quantity \_\_\_\_\_  
 FCSI Section 11400 \_\_\_\_\_  
 Approved \_\_\_\_\_  
 Date \_\_\_\_\_

## Models

- HBCC075



Model shown HBCC075

## Standard Features

- Rated capacities for 75 gallons or up to 675 lbs. of product
- Accurate PLC operating controls with HMI mounted in stainless steel NEMA 4X rated enclosures
- Paperless data recording for permanent recording of water and product temperatures and times
- Core temperature meat probe for controlling cooking and cooling
- Automatic power failure safety control
- Heavy duty stainless steel tank, type 304 construction with adjustable legs
- Rounded internal tank corners for efficient cooling and easy cleaning
- Fully insulated tank with heavy duty stainless steel removable product support panel
- Automatic water fill and water level controls with over flow protection
- Built-in 5 hp circulating pump for maximum distribution
- High efficiency shell and tube heat-exchanger for faster product cooling
- 45 KW electric heat elements for quick heat up with minimal overshoot of temperature, 3/60/460 volt
- All plumbing connections supplied with line strainers
- Cleaning cycle controls for cleaning and degreasing cook tank and heat exchangers
- Tank includes one complete basket set for products
- Heavy duty stainless steel gas spring assisted lockable cover
- Accepted for use in U.S.D.A. Inspected Facilities
- NSF/ ANSI standard 169 approved

## Short Form Specifications

Shall be Cleveland Model HBCC075 Cook Chill Tank, Rated Capacity of up to 675 lbs. fully insulated, stainless steel tank and circulation pump for optimum water distribution. Solid state controls enclosed in UL rated, stainless steel TYPE NEMA 4X enclosures. Paperless Recording with meat probe for permanent recording cooking times and temperatures. Power failure safety control. Cleaning cycles for degreasing and cleaning the tank and heat exchangers. Tank includes one complete basket set for products. Lockable gas spring assist cover assembly. Direct expansion refrigerant inline heat exchanger for cooling cycle. Inline electric heat exchanger for precise heating of water for cook cycle.

## Options & Accessories

- Extra basket set
- Dolly for basket set
- Hoists for loading and unloading product baskets
- Computer interface connections
- Spare meat probe
- Drain Tempering System
- 3/60/230 V electrical
- 3/60/208 V electrical
- Remote mounted 8 Hp air cooled condensing unit
- Remote mounted 8 Hp water cooled condensing unit
- Lift out basket carrier
- Basket Carrier Dolly

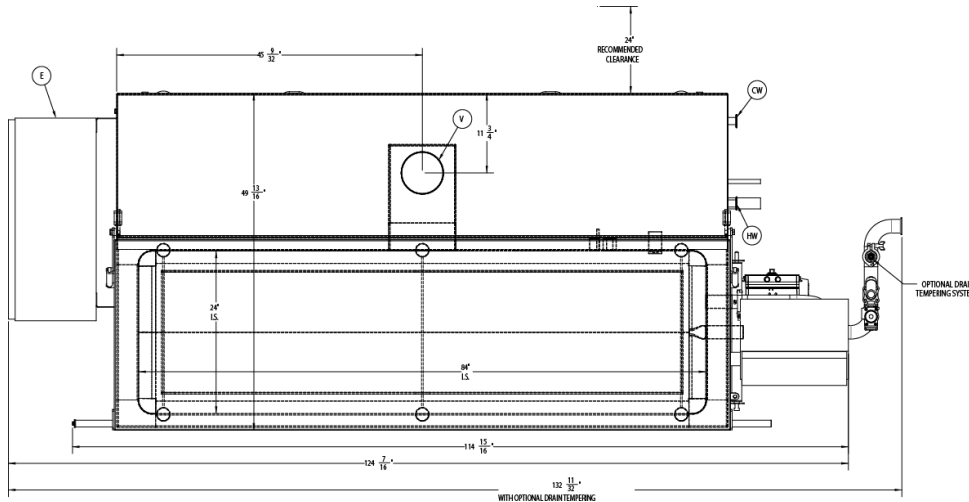

<b>MINIMUM CLEARANCE</b> (as illustrated)	
REAR	24"
RIGHT SIDE	12"
LEFT SIDE	40"
<b>MINIMUM CLEARANCE</b> (with Electrical Box remote mounted for reduced floor space)	
REAR	24"
RIGHT SIDE	12"
LEFT SIDE	8"

**Crate Size:** 142"L x 60"W x 75"H  
**Crate Weight:** 3,000 lbs  
**Rate of Class:** 85

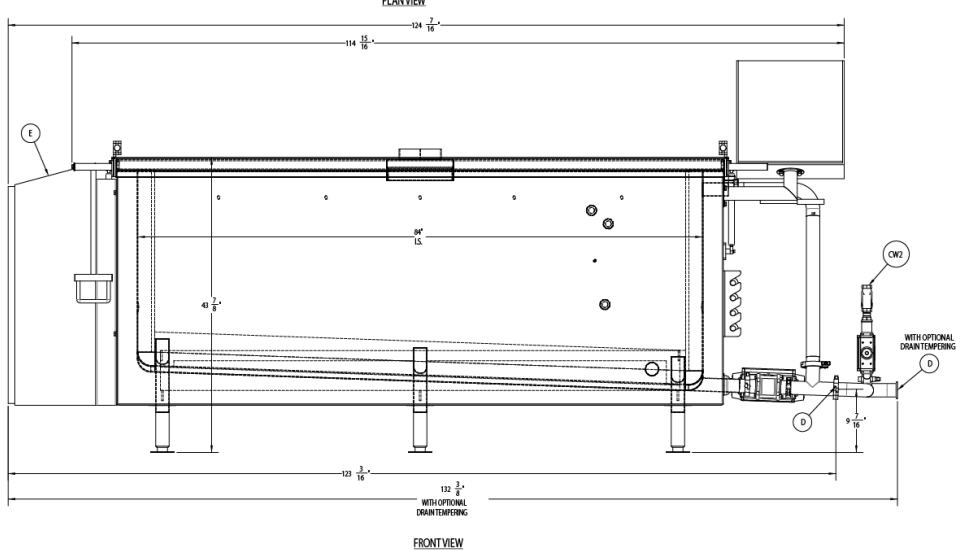

ZPCWBCC075 PRODUCT COOKER COOLER/HBCC075-60MMAN ASSY

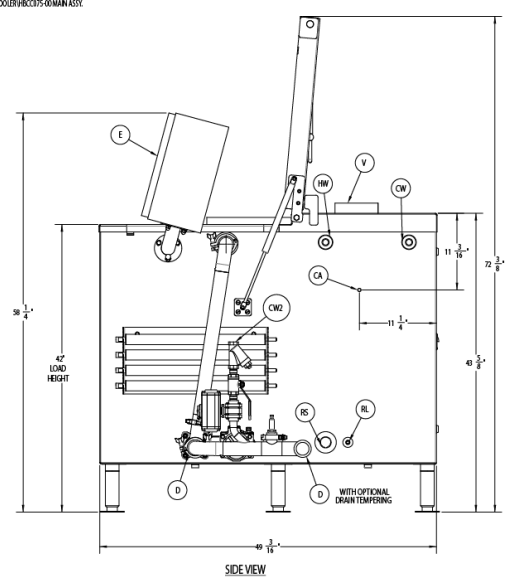

- (CW)** Cold Potable Water: 1" T-C, 150 Gal. Capacity
- (HW)** Hot Potable Water: 1" T-C, 150 Gal. Capacity @ 125°F
- (D)** Drain: 2" T-C, 75 GPM
- (V)** Exhaust Vent: 6" ID, 200 CFM
- (CA)** Compressed Air: 1/4" NPT, 5 CFM Req'd @ 90 PSI
- (P)** Pump: 5 HP, 3 Phase, 3450 RPM
- (RL)** Refrigerant Liquid Line: 5/8" ODF
- (RS)** Refrigerant Suction Line: 1 3/8" ODF, 74,000 BTU/HR @+25° FSST, @95°F Ambient
- (OF)**
- (E)** Electrical: 3PH, 60CYC, 208V, 155 Full Load Amps  
 3PH, 60CYC, 230V, 143 Full Load Amps  
 3PH, 60CYC, 480V, 69 Full Load Amps  
 Connections per Local Codes (Customer to specify requirements)

**18/2 shielded wire to be ran with the refrigeration lines. See install instructions for details of connections**

Cleveland Range reserves right of design improvement or modification, as warranted.  
 HBCC075 has a gas assisted hinged cover (as illustrated).

(NOT TO SCALE)