

BASE UNDERCOUNTER FREEZER (0°F)

Model: FA43N-U

Natural Refrigerant R-290 Model

43" Base Undercounter Freezer with Solid Doors

Heavy gauge #300 Series stainless steel top, stainless steel front and end panels, galvanized steel rear and grill and aluminum interior.



Options and Accessories

(upcharge and lead times may apply)

Stainless steel interior	Door locks
Stainless steel back	Pan slides
Stainless steel shelves	Condensing unit left (Standard on right)
Drawer in lieu of half door above the condensing unit*	Special electrical requirements (consult factory)
Additional epoxy coated steel shelves	

*Drawer section above condensing unit holds (1) 12 x 20 x 6 pan

Project Name:

Model Specified:

Location:

Item No:

Quantity:

AIA #:

SIS #:

Standard Model Features

REFRIGERATION SYSTEM

Performance rated refrigeration system

Environmentally safe R-404A refrigerant

Unique forced air design utilizes fans (approx. every 12") across the entire back of unit for even distribution of cold

Automatic, energy saving, non-electric condensate evaporator

Non-corrosive, plasticized fin evaporator coil

Expansion valve system

Easily serviceable, slide out condensing unit

CABINET ARCHITECTURE

2" non-CFC polyurethane foam insulation

Spring loaded, self closing doors

Magnetic snap in Santoprene™ door gaskets

Heavy duty, epoxy coated steel shelf

Smooth, polished chrome door handles

Completely enclosed, vented and removable rear and side grills

(8) 1 3/8" diameter plate casters mounted on heavy duty support plates (easily field installed)

MODEL FEATURES

Electronic controller with digital display & hi-low alarm

Refrigerated section with door above the condensing unit

Front breather air divider (field installed)

Automatic electric defrost

Field rehingeable doors

¹ R-290 refrigerant meets all federal and state regulatory requirements.

NOTE: Models come standard with a door over the condensing unit. A drawer over the condensing unit is an option.

Continental
Refrigerator

Toll-Free: 800-523-7138
Phone: 215-244-1400
Fax: 215-244-9579

539 Dunksferry Road
Bensalem, PA 19020
www.continentalrefrigerator.com

APPROVAL:

Model Specifications

DIMENSIONAL DATA

Net Capacity (cubic feet)	12 (340 cu l)
Width, Overall (inches)	43 (1092 mm)
Depth, Overall (inches) (including handles & bumpers)	36 1/16 (916 mm)
Height, Overall (inches) (including 1 3/8" plate casters)	31 3/4 (806 mm)
Shelf Area (square feet)	5.6 (0.5 sq m)
Number of Shelves	2
Number of Full Doors	1
Number of Half Doors	1
Interior Depth (inches)	30 (762 mm)
Interior Height (inches)	26 (660 mm)
Interior Height (inches) (above condenser)	12 1/2 (318 mm)
Interior Width (inches)	39 (991 mm)

REFRIGERANT DATA

Condensing Unit Size (H.P.)	1/3+
Capacity (BTU per hour)*	1340

ELECTRICAL DATA

Voltage (International)	115/60/1 (220/50/1)
Total Amps (International)	6.0 (3.9)
Defrost Amps (International)	6.5 (4.0)
10 ft. Cord/Plug [attached] (International)	Yes (No)

SHIPPING DATA

Weight (pounds)	340 (154 kg)
Height - Crated (inches)	43 3/4 (1111 mm)
Width - Crated (inches)	45 (1143 mm)
Depth - Crated (inches)	47 (1194 mm)

* Rating @ -15°F evaporator, 90°F ambient
Figures in parentheses reflect metric equivalents rounded to the nearest whole unit.



Equipped with one NEMA-5-15P Plug
(varies by country)

Model Plan Views

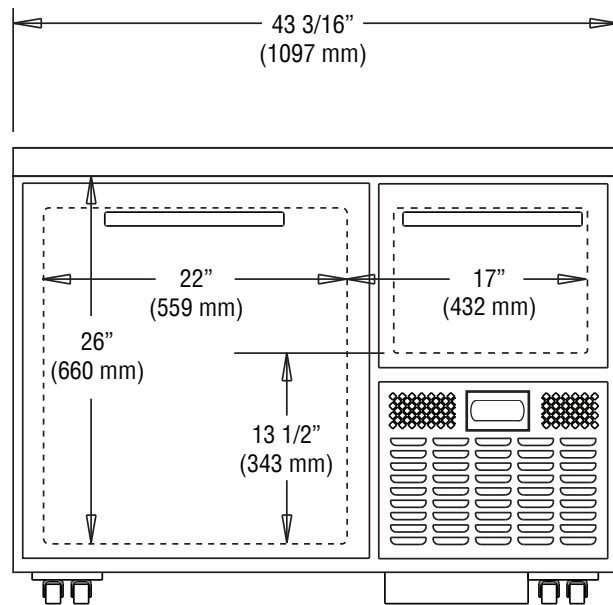

FRONT VIEW

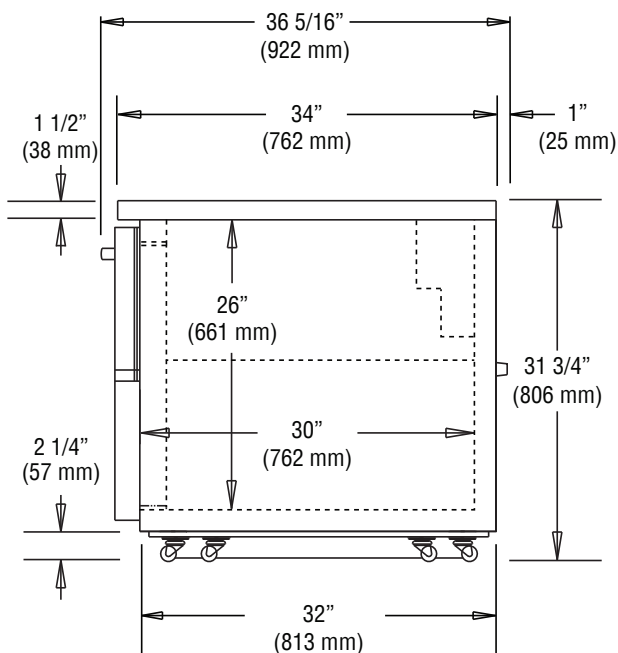

SIDE VIEW

Continental
Refrigerator

Toll-Free: 800-523-7138
Phone: 215-244-1400
Fax: 215-244-9579

539 Dunksferry Road
Bensalem, PA 19020
www.continentalrefrigerator.com

Due to our continued efforts in developing innovative products, specifications subject to change without notice.

