



ICEU150

Features

- Space-saving 24" (610 mm) wide undercounter design.
- Produces up to 238 lbs (107 kg) of ice per day.
- *Harvest Assist* provides consistent ice production for the life of the ice maker while reducing energy consumption and increasing capacity.
- *Pure Ice®* exclusively by Ice-O-Matic. Built-in antimicrobial protection for the life of the ice maker inhibits bacteria growth on ice maker surfaces. Ice-O-Matic's optional water filtration system provides protection against unpleasant tastes, odors and scale formation.
- Durable, electroless nickel plating on all evaporator plates ensures reliability.
- *Longest warranty in the industry.* Purchase an Ice-O-Matic water filter with your cube ice maker, replace the filter every six months, and the evaporator warranty is extended to 7 years parts and labor (available in the U.S. and Canada only).
- Constructed from corrosion-resistant stainless steel and fingerprint-proof plastic.

Options & Accessories

| WATER FILTERS | | | |
|-------------------|----------|-------------|---------------|
| Ice Machine Model | Manifold | | Inline |
| | System | Replacement | System |
| ICEU150 | IFQ1 | IOMQ (I) | IFI4C / IFI8C |

Ice Maker Warranty

Every Ice-O-Matic ice maker is backed by a warranty that provides both parts and labor coverage.

- Three years **Parts** and **Labor**.
- Five years **Parts** coverage on the evaporator and compressor.
- Seven years **Parts** and **Labor** on the evaporator when you purchase an Ice-O-Matic water filter with your cube ice maker and replace the filter every six months (available in the U.S. and Canada only).

Ice Form



CUBE

| FULL CUBE DIMENSIONS | |
|----------------------|---|
| W x D x H (in.) | 7 ⁵ / ₈ x 7 ⁵ / ₈ x 7 ⁵ / ₈ |
| W x D x H (mm) | 22 x 22 x 22 |
| HALF CUBE DIMENSIONS | |
| W x D x H (in.) | 3 ⁵ / ₈ x 7 ⁵ / ₈ x 7 ⁵ / ₈ |
| W x D x H (mm) | 10 x 22 x 22 |

Space-Saving Solutions

- Front air discharge design for compact spaces.
- Low profile top saves counter space.
- Stores up to 74 lbs (33.5 kg) of ice.
- Easy front access to ice.
- Available with an air-cooled or water-cooled condenser.



ICEU150 SELF CONTAINED CUBE ICE MAKER

Air and Water Cooled

- A. Ice maker water in, 3/8" FPT.
- B. Bin and ice maker drain, 3/4" FPT.
- C. Electrical cord.
- D. Condenser water in, 3/8" FPT (water cooled units only).
- E. Condenser water out, 1/2" FPT (water cooled units only).

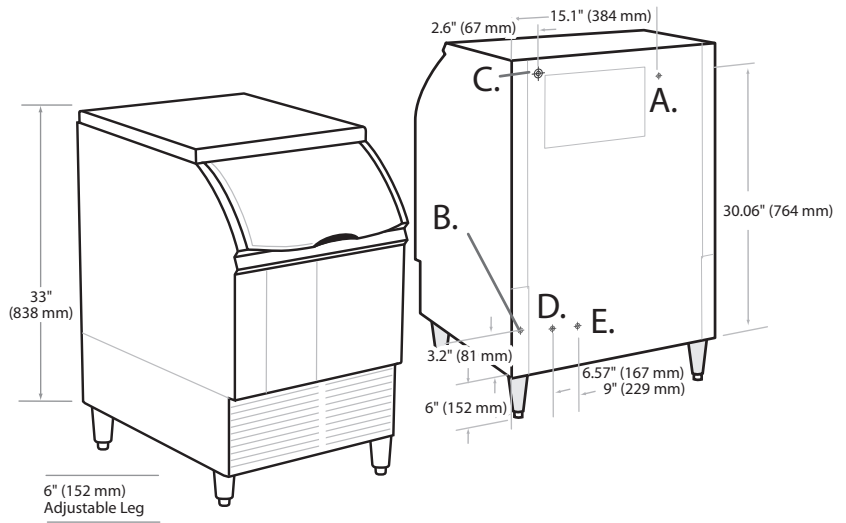
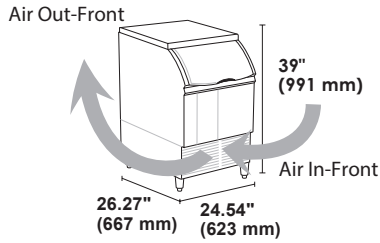

Front & Rear View

Operating Requirements

| | MINIMUM | MAXIMUM |
|-------------------------|-------------------|-------------------|
| | 60 Hz | |
| Ambient Temp. Range Air | 50°F (10°C) | 100°F (38°C) |
| Water Temp. | 40°F (4.4°C) | |
| Water Pressure | 20 PSIG (1.4 BAR) | 60 PSIG (4.1 BAR) |

Dimensions

| ALL MODELS | |
|-----------------|--------------------|
| W x D x H (in.) | 24.54 x 26.27 x 39 |
| W x D x H (mm) | 623 x 667 x 991 |

Specifications

| Model Number | Cond. Unit | Ice Production per 24hrs | | Water Usage gallons per 100 lbs of Ice 90°F air/70°F water | | kWH Used per 100 lbs of ice @ 90°F air/70°F water | Voltage Characteristics | Min. Circuit Ampacity | Max Breaker Size | Approx. BTUs per hour** |
|--------------|------------|------------------------------|------------------------------|--|-----------|---|-------------------------|-----------------------|------------------|-------------------------|
| | | 70°F air/50°F water lbs (kg) | 90°F air/70°F water lbs (kg) | Potable | Condenser | | | | | |
| ICEU150A | Air | 238 (107) | 165 (74) | 25 | - | 7.4 | 115/60/1 | 11.9 | 15 | 3,572 |
| ICEU150W | Water | 251 (113) | 193 (87) | 25 | 193 | 5.6 | | 8.9 | | 3,569 |

**BTUH is calculated 0°F Evaporator, 100°F Condensing, and 33 PSIG.

NOTES:

- Number of Wires: 3 (including ground)
- Approx. Shipping Weight lbs (kg): ICEU150A 160 (73) • ICEU150W 160 (73)
- Refrigerant Type: R404A
- *Cordset included