



Profit from the Eagle Advantage®

Specification Sheet

Short Form Specifications

Eagle Deluxe Service Mates Buffet Hot Food Table, model _____ . Polished stainless steel top with black vinyl on steel body. Individual heat wells with recessed controls, 500 watts (at 120 volts) or 750 watts (at 208 or 240 volts) per well. Clear polycarbonate sneeze guard. Portable units feature black vinyl base and 4" swivel casters, two with brakes. Tabletop units feature adjustable feet for mounting onto tabletop.

Eagle Deluxe Service Mates Buffet Cold Pan Unit, model _____ . Polished stainless steel insulated ice cold pan, 6" deep with black vinyl on steel body. Clear polycarbonate sneeze guard. Portable units feature black vinyl base and 4" swivel casters, two with brakes. Tabletop units feature adjustable feet for mounting onto tabletop.



portable buffet hot food table

tabletop buffet cold pan table

Options / Accessories (see back page of EG30.16B)

- Fluorescent lights
- Vinyl skirts*
- Stainless steel skirts*
- Tray shelves
- Undershelf*
- Infrared bullet lamps
- Wood trimmed sneeze guards
- Stainless steel liners
- Stainless steel body upgrade
- 1000W heaters (for 240V units)

* For portable units

EAGLE GROUP

100 Industrial Boulevard, Clayton, DE 19938-8903 USA
 Phone: 302-653-3000 • 800-441-8440 • Fax: 302-653-2065
www.eaglegrp.com
www.eaglegrpnews.com
www.eaglemhc.com

For custom configuration or fabrication needs, contact our SpecFAB® Division.
 Phone: 302-653-3000 • Fax: 302-653-2065 • e-mail: quotes@eaglegrp.com

Item No.: _____
 Project No.: _____
 S.I.S. No.: _____

Deluxe Service Mates— Buffet Hot Food and Cold Pan Units

MODELS:

- | | | | |
|--------------------------------------|--------------------------------------|-------------------------------------|---------------------------------|
| <input type="checkbox"/> BPDHT2-120 | <input type="checkbox"/> BPDHT4-120 | <input type="checkbox"/> CDHT3-120 | <input type="checkbox"/> BPCP-2 |
| <input type="checkbox"/> BPDHT2-208* | <input type="checkbox"/> BPDHT4-208* | <input type="checkbox"/> CDHT3-208* | <input type="checkbox"/> BPCP-3 |
| <input type="checkbox"/> BPDHT2-240* | <input type="checkbox"/> BPDHT4-240* | <input type="checkbox"/> CDHT3-240* | <input type="checkbox"/> BPCP-4 |
| <input type="checkbox"/> BPDHT3-120 | <input type="checkbox"/> CDHT2-120 | <input type="checkbox"/> CDHT4-120 | <input type="checkbox"/> CCP-2 |
| <input type="checkbox"/> BPDHT3-208* | <input type="checkbox"/> CDHT2-208* | <input type="checkbox"/> CDHT4-208* | <input type="checkbox"/> CCP-3 |
| <input type="checkbox"/> BPDHT3-240* | <input type="checkbox"/> CDHT2-240* | <input type="checkbox"/> CDHT4-240* | <input type="checkbox"/> CCP-4 |

* Available in three-phase. To order, add suffix "-3". Example: BPDHT3-240-3

Portable Buffet Hot Food Tables

- Clear polycarbonate sneeze guard.
- Polished 22 gauge type 430 stainless steel top.
- Black vinyl-clad 22 gauge steel body.
- Black vinyl-clad 18 gauge steel base.
- Individual heat wells with separate controls.
- 4" (102mm) swivel casters, two with brake.
- 22 $\frac{5}{8}$ " (573mm) front-to-back**, 52 $\frac{3}{4}$ " (1340mm) height.

Tabletop Buffet Hot Food Tables

- Clear polycarbonate sneeze guard.
- Polished 22 gauge type 430 stainless steel top.
- Black vinyl-clad 22 gauge steel body.
- Individual control for each well.
- Adjustable feet for mounting on tabletop.
- 22 $\frac{5}{8}$ " (573mm) front-to-back**, 34 $\frac{5}{8}$ " (880mm) height.

Portable Buffet Cold Food Tables

- Clear polycarbonate sneeze guard.
- Polished 20 gauge type 304 stainless steel insulated ice type cold pan.
- Black vinyl-clad 22 gauge steel body.
- Black vinyl-clad 18 gauge steel base.
- 4" (102mm) swivel casters, two with brake.
- 22 $\frac{5}{8}$ " (573mm) front-to-back**, 52 $\frac{3}{4}$ " (1340mm) height.

Tabletop Buffet Cold Food Tables

- Clear polycarbonate sneeze guard.
- Polished 20 gauge type 304 stainless steel insulated ice type cold pan.
- Black vinyl-clad 22 gauge steel body.
- Adjustable feet for mounting on tabletop.
- 22 $\frac{5}{8}$ " (573mm) front-to-back**, 34 $\frac{5}{8}$ " (880mm) height.

** Unit width only—does not include sneeze guard.

Certifications / Approvals
 (Buffet Hot Food Tables)

AQ AutoQuotes



EG30.16A Rev. 10/22

Spec sheets available for viewing, printing or downloading from our online literature library at our websites



Profit from the Eagle Advantage®

Item No.: _____
 Project No.: _____
 S.I.S. No.: _____

Deluxe Service Mates—Buffet Hot Food and Cold Pan Units

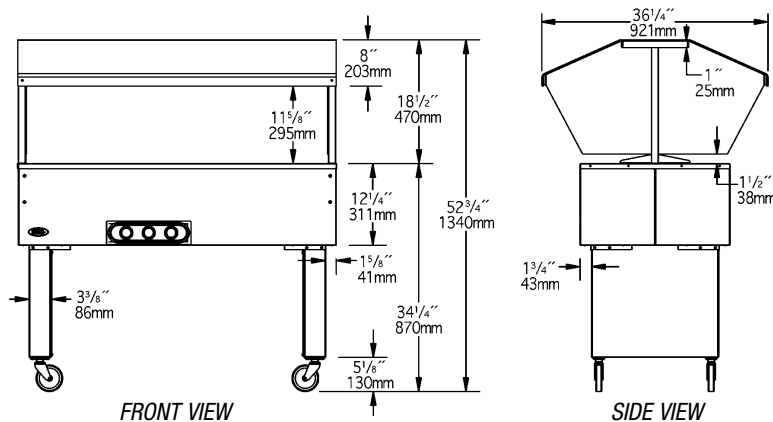

(note: 3-well portable buffet hot food table shown)

Receptacle Configurations Required

See charts below for applicable NEMA plug.

15A 120V	15A 240V	20A 240V	30A 120V	20A 3Ø 240V
furnished with NEMA 5-15 plug	furnished with NEMA 6-15 plug	furnished with NEMA 6-20 plug	furnished with NEMA 5-30 plug	furnished with NEMA 15-20 plug

Buffet Hot Food Tables—Single-Phase Units

PORTABLE MODELS			TABLETOP MODELS			# of top openings	length		watts	volts	amps	NEMA plug
model #	weight		model #	weight			in.	mm				
BPDHT2-120	232	105.2	CDHT2-120	149	67.6	2	33"	838	1000W	120V	8.3A	5-15P
BPDHT2-208	232	105.2	CDHT2-208	149	67.6	2	33"	838	1500W	208V	7.2A	6-15P
BPDHT2-240	232	105.2	CDHT2-240	149	67.6	2	33"	838	1500W	240V	6.25A	6-15P
BPDHT3-120	264	119.8	CDHT3-120	189	85.7	3	48"	1219	1500W	120V	12.5A	5-15P
BPDHT3-208	264	119.8	CDHT3-208	189	85.7	3	48"	1219	2250W	208V	10.8A	6-15P
BPDHT3-240	264	119.8	CDHT3-240	189	85.7	3	48"	1219	2250W	240V	9.38A	6-15P
BPDHT4-120	360	163.3	CDHT4-120	234	106.1	4	63 1/2"	1613	2000W	120V	16.6A	5-30P
BPDHT4-208	360	163.3	CDHT4-208	234	106.1	4	63 1/2"	1613	3000W	208V	14.4A	6-20P
BPDHT4-240	360	163.3	CDHT4-240	234	106.1	4	63 1/2"	1613	3000W	240V	12.5A	6-20P

Buffet Hot Food Tables—Three-Phase Units

PORTABLE MODELS			TABLETOP MODELS			# of top openings	length		watts	volts	amps	NEMA plug
model #	weight		model #	weight			in.	mm				
BPDHT2-208-3	232	105.2	CDHT2-208-3	149	67.6	2	33"	838	1500W	208V	6.3A	15-20P
BPDHT2-240-3	232	105.2	CDHT2-240-3	149	67.6	2	33"	838	1500W	240V	5.4A	15-20P
BPDHT3-208-3	264	119.8	CDHT3-208-3	189	85.7	3	48"	1219	2250W	208V	6.3A	15-20P
BPDHT3-240-3	264	119.8	CDHT3-240-3	189	85.7	3	48"	1219	2250W	240V	5.4A	15-20P
BPDHT4-208-3	360	163.3	CDHT4-208-3	234	106.1	4	63 1/2"	1613	3000W	208V	9.5A	15-20P
BPDHT4-240-3	360	163.3	CDHT4-240-3	234	106.1	4	63 1/2"	1613	3000W	240V	8.3A	15-20P

Buffet Cold Pan Units

PORTABLE MODELS				TABLETOP MODELS							
weight		height		model #	weight		height		model #	length	
lbs.	kg	in.	mm		lbs.	kg	in.	mm		in.	mm
232	105.2	52 3/4"	1337	BPCP-2	137	62.1	34 3/4"	880	CCP-2	33"	838
269	122.0	52 3/4"	1337	BPCP-3	157	71.2	34 3/4"	880	CCP-3	48"	1219
305	138.4	52 3/4"	1337	BPCP-4	235	106.6	34 3/4"	880	CCP-4	63 1/2"	1613

EAGLE GROUP

100 Industrial Boulevard, Clayton, DE 19938-8903 USA

Phone: 302-653-3000 or 800-441-8440 • Fax: 302-653-2065

www.eaglegrp.com • www.eaglegrpnews.com • www.eaglehmc.com

Printed in U.S.A.
 ©2022 by Eagle Group

Rev. 10/22

Spec sheets available for viewing, printing or downloading from our online literature library at our websites

Although every attempt has been made to ensure the accuracy of the information provided, we cannot be held responsible for typographical or printing errors. Information and specifications are subject to change without notice. Please confirm at time of order.