



Project _____
 AIA # _____ SIS # _____
 Item # _____ Quantity _____ C.S.I. Section 114000



RMC SERIES - MILK COOLERS

RMC SERIES MILK COOLER 8 CRATE CAPACITY MODELS



Model Shown - RMC49D4

STANDARD PRODUCT FEATURES

- Stainless Steel Exterior & Interior
- Top Mounted Removable Refrigeration System
- Forced Air Refrigeration System
- Accommodates (8) 13" x 13" Crate(s) or (4) 13" x 19" Crate(s)
- Single or Double Sided
- Sliding Lift Up & Down Door(s)
- Reinforced Cabinet Exterior Bottom
- Heavy Duty Dunnage Racks Protect Cabinet & Promote Airflow
- Lockable Insulated Doors
- Metal Door Handles
- Magnetic Snap-In EZ-Clean Door Gasket(s)
- Floor Drain with Plug
- 8' Cord & Plug Attached
- Set of Four (4) 6" or 4" Factory Mounted Adjustable Casters
- 3-Year Parts & Labor Warranty
- 2-Year Additional Compressor Parts Warranty



This unit is listed to the applicable UL, CSA and NSF Standards by an approved NRTL. Consult the factory or unit's data plate for approval information.

ACCESSORIES & OPTIONS (*field installed)

- MCACC-BUMPER, Bumper Corner Guard Kit (4)

AVAILABLE CONFIGURATIONS

Single Access Models

RMC34S4 8 Crate 34" Length, 4" Casters
 RMC34S6 8 Crate 34" Length, 6" Casters

Double Access Models

RMC34D4 8 Crate 34" Length, 4" Casters
 RMC34D6 8 Crate 34" Length, 6" Casters

Approved by _____ Date _____ Approved by _____ Date _____



MODELS

Single Access Models: RMC34S4, RMC34S6

Double Access Models: RMC34D4, RMC34D6

CLICK
TRANSFER
For KCL CADalog Website

Single Access Models

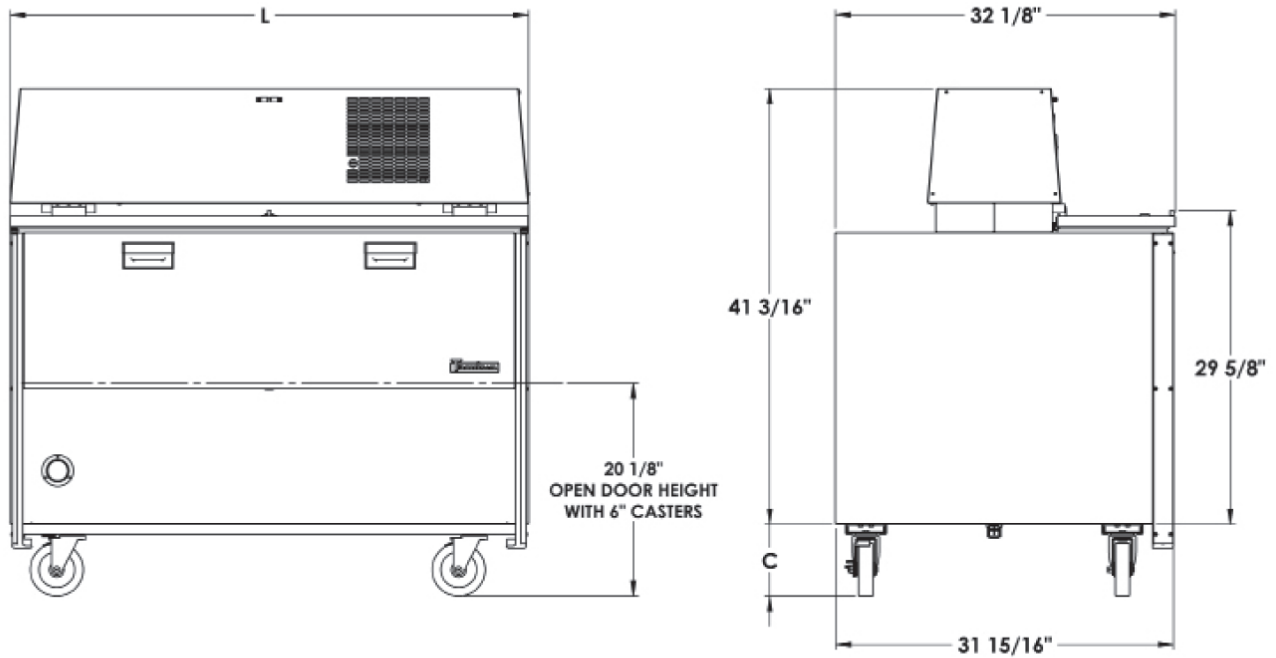

Double Access Models

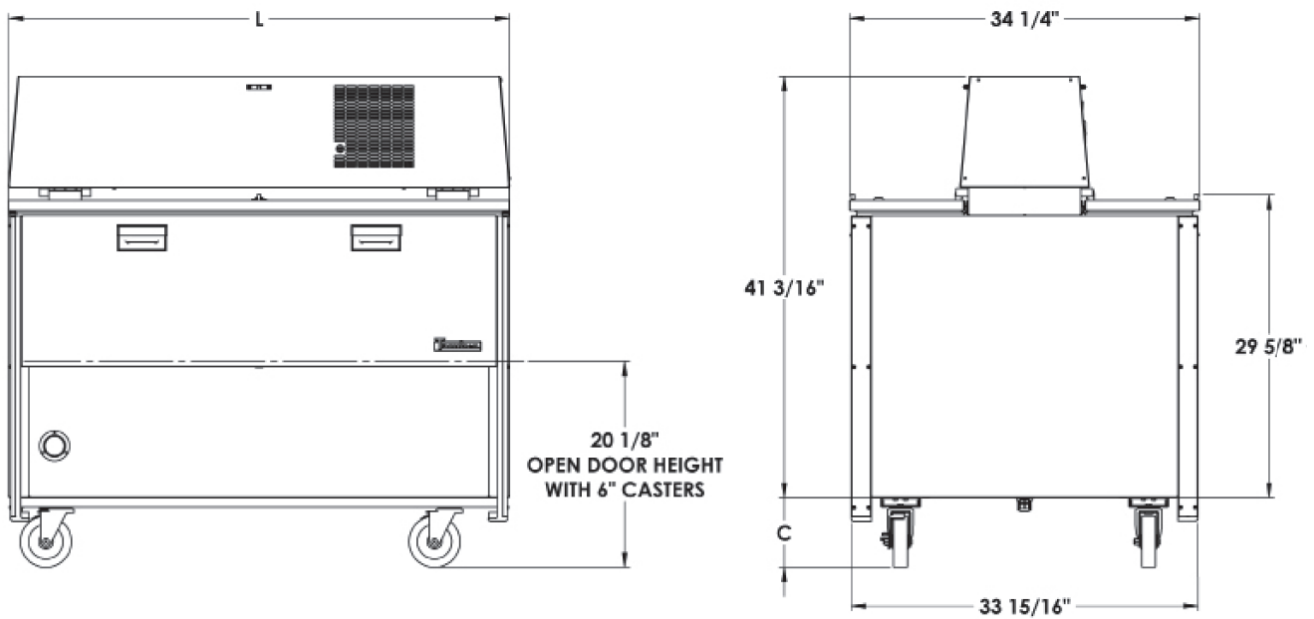



RMC SERIES

MILK COOLER

8 CRATE CAPACITY MODELS

MODELS

Single Access Models: RMC34S4, RMC34S6

Double Access Models: RMC34D4, RMC34D6

MODELS	RMC34
DIMENSIONAL DATA	
Net Crate Capacity 13 x 13 in. ¹	8
Net Crate Capacity 13 x 19 in. ¹	4
Length -Overall in.	34 (86.4 cm)
Depth-Single Cabinet Only in.	32 1/8 (81.6 cm)
Depth-Double Cabinet in.	34 1/4 (87 cm)
Height-Overall on 6" Casters	48 (124.5 cm)
Net Weight uncrated lbs. (kg)	395 (179)
ELECTRICAL DATA	
Voltage	115/60/1
Single Access Full Load Amperes MDEC ²	7.2 1.85 kWh/Day
Double Access Full Load Amperes MDEC ²	7.2 1.88 kWh/Day
NEMA Plug Type	5-15P
Single Access Cabinet Volume	11.72
Double Access Cabinet Volume	12.46
REFRIGERATION DATA	
Refrigerant	R-450A
Refrigerant Amount oz. (gr)	9.5 (269)
BTU ³ /HR	1660

NOTE:

* Figures in parentheses reflect metric equivalents.

1. Net Capacity cu. ft.

2. MDEC = Maximum Daily Energy Consumption

3. Based on a 90°F ambient and 20°F evaporator.

EQUIPMENT SPECIFICATIONS

CONSTRUCTION, HARDWARE, INSULATION

Cabinet exterior and interior is constructed of stainless steel. Interior sides, back and front are also stainless steel. The exterior cabinet bottom is constructed of stainless steel.

Gasket profile and material simplify cleaning and increase overall gasket life.

Both the cabinet and doors are insulated with non-CFC, foamed in place polyurethane.

DOOR/ACCESS

Front sliding protects gasket(s). Lockable lift up top access door.

REFRIGERATION SYSTEM

A balanced, top mounted side and front and rear breathing, refrigeration system using environmentally friendly, non-flammable R-450A refrigerant is provided. It features an air-cooled hermetic compressor and a forced air evaporator coil. An 8' cord and plug is provided. Standard operating temperature is 34° to 38°F (1.1° to 3.3°C).

CONTROLLER

An electronic digital control is supplied standard. It includes a 3-Digit LED display, and a Fahrenheit or Celsius temperature scale display capability.

INTERIOR/DUNNAGE RACKS

Heavy duty removable dunnage racks protect cabinet and promote airflow.

WARRANTIES

Both a three year parts and labor warranty and five year compressor parts warranty.



Equipped With One NEMA 5-15 P Plug

Note: When ordering please specify: Door Access, Caster Height and other options.
Continued product development may necessitate specification changes without notice.

CONTINUED PRODUCT DEVELOPMENT MAY NECESSITATE SPECIFICATION CHANGES WITHOUT NOTICE.