

DISPLAY REFRIGERATOR

Model: 2RNGDHD

Natural Refrigerant R-290 Model

2-Section Display Reach-In Refrigerator with Half Hinged Glass Doors



ENERGY STAR® Qualified Commercial Refrigerator

2RNGDHD - Stainless steel front, aluminum end panels and interior

2RNSAGDHD - Stainless steel exterior, aluminum interior

2RNSSGDHD - Stainless steel exterior and interior



Options and Accessories

(upcharge and lead times may apply)

Stainless steel case back	Pan slide assemblies
Additional epoxy coated steel shelves	Wine rack
Chrome or stainless steel shelves	Adjustable legs
Heavy duty pilaster strips	Pass-thru (consult factory)
Rehinging of doors (consult factory)	Special electrical req. (consult factory)
Full doors	Shallow depth (consult factory)
Solid door (consult factory)	

Consult factory for other model configurations, options and accessories.

Continental
Refrigerator

Toll-Free: 800-523-7138
Phone: 215-244-1400
Fax: 215-244-9579

539 Dunksferry Road
Bensalem, PA 19020
www.continentalrefrigerator.com

Project Name:

Model Specified:

Location:

Item No:

Quantity:

AIA #:

SIS #:

Standard Model Features

REFRIGERATION SYSTEM

Self contained, performance rated refrigeration system

Natural, environmentally safe, high efficiency R-290 refrigerant¹

Automatic, electric condensate evaporator

Expansion valve system

CABINET ARCHITECTURE

3" non-CFC polyurethane foam insulation

Triple-pane, tempered hinged glass doors

Chrome plated handles

Cam action, lift-off hinges

Self-closing doors

Magnetic snap in door gaskets

Cylinder lock in door in each door

Heavy duty, epoxy coated steel shelves

5" casters

MODEL FEATURES

LED interior lighting

Off cycle defrost

Electronic controller with digital display & hi-low alarm

¹ R-290 refrigerant meets all federal and state regulatory requirements.

APPROVAL:

Model Specifications

DIMENSIONAL DATA

Net Capacity (cubic feet)	48 (1359 cu l)
Width, Overall (inches)	52 (1321 mm)
Depth, Overall (inches) (including handles)	35 3/8 (899 mm)
Depth (inches) (less doors)	32 (813 mm)
Depth (inches) (doors open 90°)	55 1/2 (1410 mm)
Clear Door Width (inches)	19 3/8 (492 mm)
Clear Half Door Height (inches)	27 1/2 (699 mm)
Height, Overall (inches) (including 5" casters)	82 1/4 (2096 mm)
Number of Doors	4
Number of Shelves	8
Shelf Area (square feet)	40.8 (3.8 sq m)
Tray Slide Capacity (per half section)	11

REFRIGERANT DATA

Condensing Unit Size (H.P.)	1/3+
Capacity (BTU per hour)*	2560

ELECTRICAL DATA

Voltage (International)	115/60/1 (220/50/1)
Feed Wires (including ground)	3
Total Amps (International)	8.4 (5.1)
10 ft. Cord/Plug [attached] (International)	Yes (No)

SHIPPING DATA

Height - Crated (inches)	85 1/2 (2172 mm)
Width - Crated (inches)	64 (1626 mm)
Depth - Crated (inches)	42 (1067 mm)
Volume - Crated (cubic feet)	133 (3766 cu l)
Weight Std - Crated (pounds)	530 (143 kg)
Weight SS - Crated (pounds)	560 (254 kg)

* Rating @ +25°F evaporator, 90°F ambient

Figures in parentheses reflect metric equivalents rounded to the nearest whole unit.



Equipped with one NEMA-5-15P Plug
(varies by country)

Model Plan Views

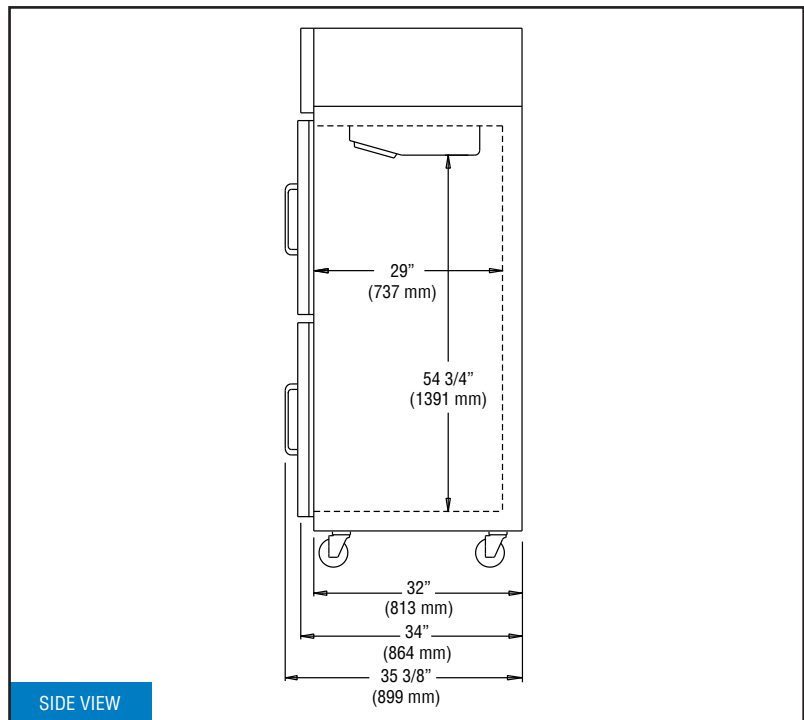
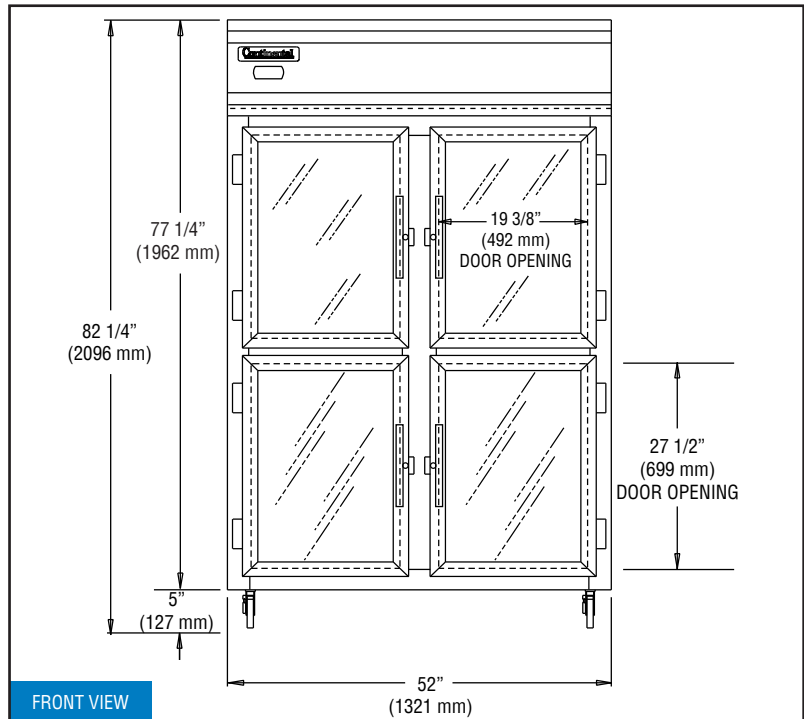

IMPORTANT NOTE: If the cabinet is located directly against a wall and/or under a low ceiling, a minimum clearance of 12" is required on top and 3" on sides and rear.

Continental
Refrigerator

Toll-Free: 800-523-7138
Phone: 215-244-1400
Fax: 215-244-9579

539 Dunksferry Road
Bensalem, PA 19020
www.continentalrefrigerator.com

Due to our continued efforts in developing innovative products, specifications subject to change without notice.

