

BOTTLE COOLER (38°F - 41°F)

Model: BC50NSS

50" Bottle Cooler

Stainless steel exterior with all stainless steel countertop and slide lids, heavy duty galvanized interior.



Options and Accessories

(upcharge and lead times may apply)

Stainless steel interior	Casters
Additional wire bin dividers	Adjustable legs
Lid locks	

Consult factory for other model configurations, options and accessories.

Continental
Refrigerator



Project Name:

Model Specified:

Location:

Item No:

Quantity:

AIA #:

SIS #:

Standard Model Features

REFRIGERATION SYSTEM

Environmentally safe R-290 refrigerant

Performance rated refrigeration system

Automatic, hot gas condensate evaporator

Full length, extra large coil

Expansion valve system

Easily accessible and serviceable slide out condensing unit

CABINET ARCHITECTURE

High density, non-CFC polyurethane foamed-in-place insulation

Heavy duty, epoxy coated, adjustable steel wire storage bin dividers

Front, rear and side venting louvers

MODEL FEATURES

Heavy duty cap opener with extra capacity, removable cap catcher

Easily accessible, front mounted cleanout drainage hose

Electronic control, off-cycle defrost

APPROVAL:

Model Specifications

DIMENSIONAL DATA

Net Capacity (cubic feet)	15.1 (428 l)
12 oz. Bottle Capacity (# cases)	15 3/4
12 oz. Can Capacity (# cases)	27
Width, Overall (inches)	50 (1270 mm)
Depth, Overall (inches) (including bumpers & cap catcher)	29 1/8 (740 mm)
Height, Overall (inches)	33 1/2 (851 mm)
Number of Slide Lids	2
Number of Bin Dividers	3

REFRIGERANT DATA

Condensing Unit Size (H.P.)	1/4
R-290 Refrigerant Charge (oz)	3.9
Capacity (BTU per hour)*	1740

ELECTRICAL DATA

Voltage (International)	115/60/1 (220/50/1)
Feed Wires (including ground)	3
Total Amps (International)	3.0 (1.5)
10 ft. Cord/Plug [attached] (International)	Yes (No)

SHIPPING DATA

Weight - (pounds)	315 (155 kg)
Height - Crated (inches)	41 (991 mm)
Width - Crated (inches)	58 (1467 mm)
Depth - Crated (inches)	31 (768 mm)

* Rating @ +20°F evaporator, 90°F ambient
Figures in parentheses reflect metric equivalents rounded to the nearest whole unit.



Equipped with one NEMA-5-15P Plug
(varies by country)

Continental
Refrigerator

Toll-Free: 800-523-7138
Phone: 215-244-1400
Fax: 215-244-9579

539 Dunksferry Road
Bensalem, PA 19020
www.continentalrefrigerator.com

Due to our continued efforts in developing innovative products, specifications subject to change without notice.



PROUDLY
DESIGNED & ASSEMBLED
IN THE U.S.A.

© Copyright 2021. Continental Refrigerator.

Model Plan Views

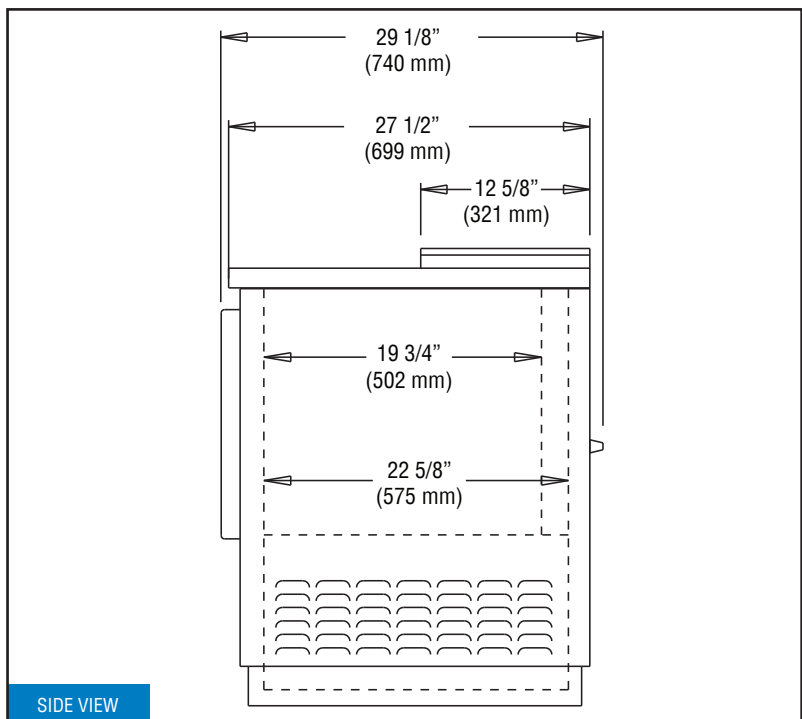
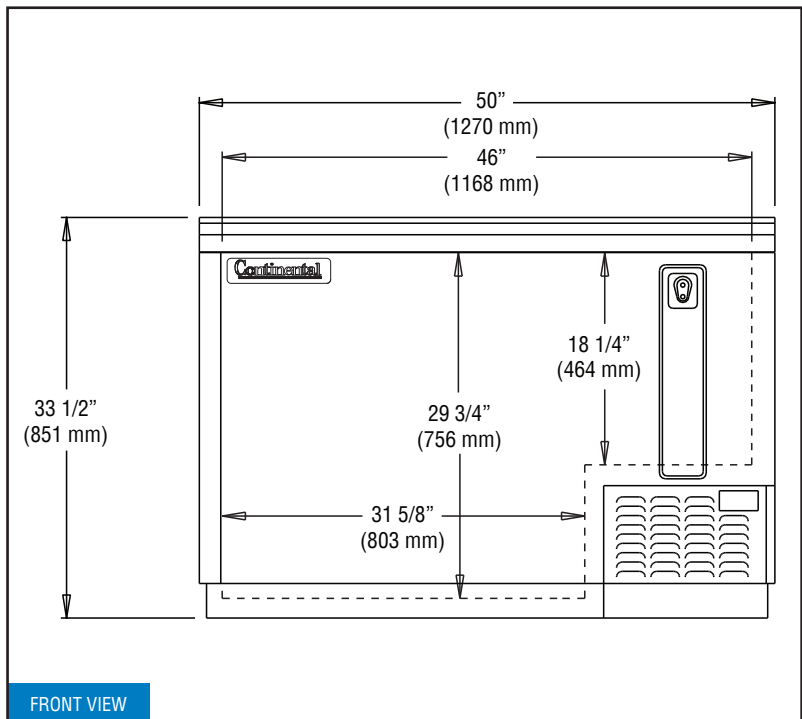

IMPORTANT NOTE: A minimum clearance of 3" is required on each side, front and rear of cabinet for optimum performance.

REVISED: 4/29/26