



PROJECT NAME	LOCATION		AIA #
ITEM #	QTY	MODEL #	SIS #

# SPEC SERIES®

ROLL-IN SOLID SWING DOOR FREEZER WITH HYDROCARBON REFRIGERANT

models	STR2FRI-2S-HC	STA2FRI-2S-HC	STG2FRI-2S-HC
--------	---------------	---------------	---------------



STR2FRI-2S	
Exterior	Stainless steel door, front & sides.
Interior	Stainless steel side walls, back, floor, door liner, & ceiling.

STA2FRI-2S	
Exterior	Stainless steel door, front & sides.
Interior	Aluminum side walls & back. Stainless steel floor & ceiling.

STG2FRI-2S	
Exterior	Stainless steel door, with matching aluminum sides.
Interior	Aluminum side walls & back. Stainless steel floor & ceiling.

## plan view

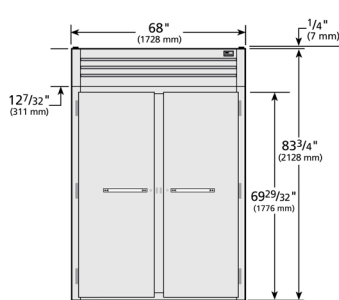

ELEVATION

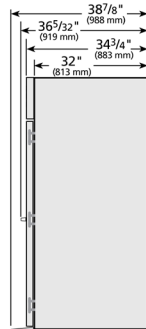

RIGHT VIEW

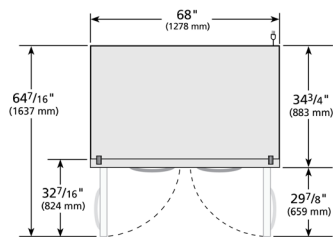

PLAN VIEW

SPECIFICATIONS		
Dimensions	in.	mm.
Length	68	1728
Depth	34 3/4	883
Height	83 3/4	2128
Electrical	U.S.	International
Horsepower	1 1/4	N/A
Amps	12.6	N/A
Voltage	115/60/1	
NEMA	5-20P	
Cord Length	10 ft.	3.05 M.
115/60/1 NEMA-5-20R		
† Depth does not include 4 1/4" (108 mm) for ramp. * Height does not include 1" (26 mm) for system mechanical components. Note: Requires 115/208-230/60Hz, single phase, 3 pole, 4 wire circuit.		

Specifications subject to change without notice.  
 Chart dimensions are rounded up to the nearest 1/8" (millimeters rounded up to the next whole number).



PROJECT NAME	LOCATION	AIA #
ITEM #	QTY	MODEL #
		SIS #

# SPEC SERIES®

ROLL-IN SOLID SWING DOOR FREEZER WITH HYDROCARBON REFRIGERANT

models	STR2FRI-2S-HC	STA2FRI-2S-HC	STG2FRI-2S-HC
--------	---------------	---------------	---------------



## standard features

### REFRIGERATION SYSTEM

- Factory engineered, self-contained, expansion valve (TXV) system using environmentally friendly R290 hydrocarbon refrigerant that has zero (0) ozone depletion potential (ODP), & 0.02 global warming potential (GWP).
- Extra large evaporator coil balanced with higher horsepower compressor and large condenser maintains -10°F (-23.3°C) cabinet temperature. Ideal for both frozen foods and ice cream.
- State of the art, electronically commutated evaporator and condenser fan motors. ECM motors operate at higher peak efficiencies and move a more consistent volume of air which produces less heat, reduces energy consumption and provides greater motor reliability.
- Top mounted refrigeration system with evaporator positioned out of food zone to maximize capacity.
- Automatic defrost system time-initiated, temperature-terminated. Saves energy consumption and provides shortest possible defrost cycle.
- Automatic evaporator fan motor delay during defrost cycle.

### CABINET CONSTRUCTION

- Insulation - Entire cabinet structure and solid door are foamed-in-place using a high density, polyurethane insulation that has zero ozone depletion potential (ODP) and zero global warming potential (GWP).
- Designed to accept roll-in racks (inboard castors) with maximum dimensions of 27"L x 29"D x 66"H (686 mm x 737 mm x 1677 mm) (supplied by others).
- One (1) heavy gauge stainless steel ramp.

### DOORS

- Lifetime guaranteed bolt style door locks standard.
- Lifetime guaranteed heavy duty all metal working door handle.
- Positive seal self-closing door with 120° stay open feature. Lifetime guaranteed external cam lift door hinges, Three (3) per door section.
- Magnetic door gasket of one piece construction, removable without tools for ease of cleaning.

### LIGHTING

- LED interior lighting, safety shielded.

### MODEL FEATURES

- Exterior digital temperature display, available with either °F or °C .
- Evaporator epoxy coated to eliminate the potential of corrosion
- Backguard improves airflow.
- Interior bumpers protect cabinet walls from abuse caused by roll-in carts.
- NSF/ANSI Standard 7 compliant for open food product.

### ELECTRICAL

- Unit completely pre-wired at factory and ready for final connection to a 115/60/1 phase, 20amp dedicated outlet. Cord and plug set included.

### OPTIONAL FEATURES/ ACCESSORIES

- (upcharge & lead times may apply)*
- Stainless back. (STR, STA, STG)

METRIC DIMENSIONS ROUNDED UP TO THE NEAREST WHOLE MILLIMETER  
 SPECIFICATIONS SUBJECT TO CHANGE WITHOUT NOTICE

	Model	Elevation	Right	Plan	3D	Back
	ST( )2FRI-2S-HC					