

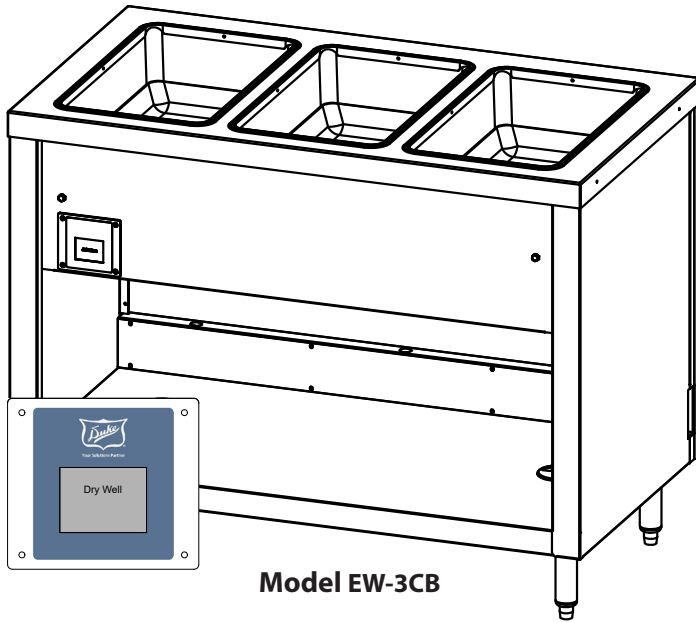

Your Solutions Partner

Specifications

F.O.B. Sedalia, Missouri 65301



Model EW-3CB

OPTIONS:

- 10" wide maple carving board, stainless steel brackets
- 14 gauge tops
- Heated base module
- Sliding Doors
- Cord and plug
- Adaptor plates
- Casters (add cord and plug), 5" swivel with locks
- Casters (add cord and plug), 5" swivel no lock
- Veneered panels
- 1/2" poly cutting surface added to stainless steel carving board
- Foodshields
- Trayslides and carving boards
- Push Bar
- Electric outlet in base
- Telescoping cover
- Pass through body
- Dish Shelf under cutting board

DUKE MANUFACTURING CO.

2305 N. Broadway

St. Louis, MO 63102

800.735.3853 Toll Free

314.231.5074 Fax

www.dukemfg.com

SS-1256 Ganged Waterless Well - Stand Thurmaduke

Approval Stamp(s):

PRODUCT INFORMATION:

PROJECT: _____

ITEM: _____

QUANTITY: _____

MODEL:

Thurmaduke® Ganged Waterless Well Hot Food Units - Standard

- EW-2CBPG/EW-2CBSS 2 top openings
- EW-3CBPG/EW-3CBSS 3 top openings
- EW-4CBPG/EW-4CBSS 4 top openings
- EW-5CBPG/EW-5CBSS 5 top openings
- EW-6CBPG/EW-6CBSS 6 top openings

TOP:

- One piece. 16 gauge, 300 Series stainless steel
- Top openings die - stamped. 11-7/8" X 19-7/8"

Heat Compartments:

- 6-1/4" deep stainless steel liner for dry operation only
- Includes Silicone bottom pad
- Fully Insulated
- Rope element in each compartment

CONTROLS:

- Standard intuitive, easy to use touch screen control - One control for all wells
- Easily adjusted presets LOW/MED/HIGH
- Built in WIFI and Bluetooth for future connectivity.

BODY AND INTERIOR SHELF:

- 300 Series stainless steel
- Paint grip steel
- 6" polished stainless steel adjustable legs
- Full bottom shelf to match body

Certifications



Specification subject to change



Thurmaduke®

Ganged Waterless Well Standard Counter

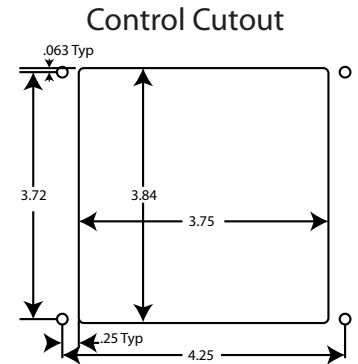
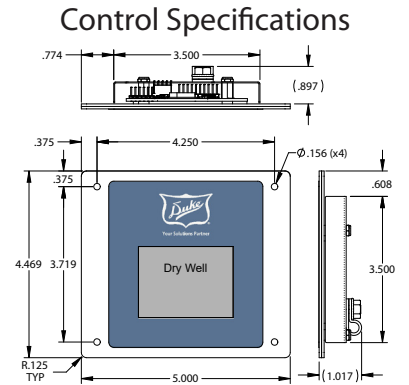
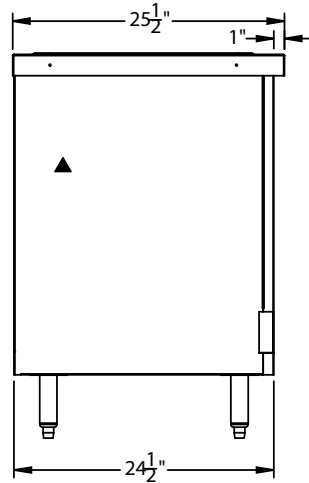
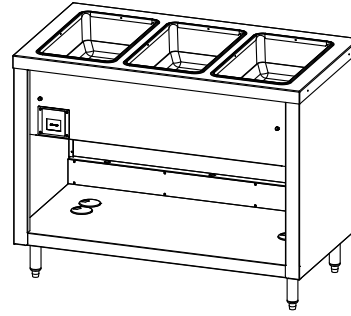
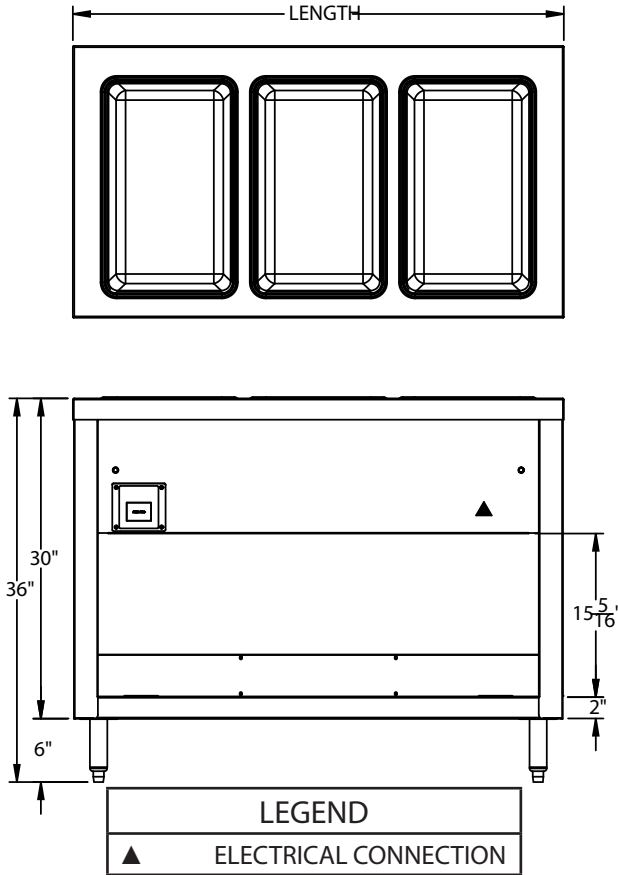

DIMENSIONS:

FREIGHT CLASS: 150

Model		Length		Depth		Height		Top Openings	Cube ft. Crated	Weight	
Enameled	Stainless	in	cm	in	cm	in	cm			lbs	kg
EW-2-CBPG	EW-2-CBSS	32	81.3	25-1/2	64.8	36	91.4	2	28.1	210	95.5
EW-3-CBPG	EW-3-CBSS	46	116.8	25-1/2	64.8	36	91.4	3	39.6	264	120.0
EW-4-CBPG	EW-4-CBSS	60	152.4	25-1/2	64.8	36	91.4	4	51.2	344	156.4
EW-5-CBPG	EW-5-CBSS	74	188.0	25-1/2	64.8	36	91.4	5	62.3	433	196.8
EW-6-CBPG	EW-6-CBSS	88	223.5	25-1/2	64.8	36	91.4	6	74.3	527	239.6

ELECTRICAL SPECIFICATIONS:

Cord & NEMA plug NOT included

Model	120 Volt - 665 watt			208 Volt - 500 watt			240 Volt - 665 watt		
	Watts	Amps	NEMA	Watts	Amps	NEMA	Watts	Amps	NEMA
EW-2-CBPG/SS	1330	11.1	5-15	1000	4.8	6-20	1330	5.5	6-20
EW-3-CBPG/SS	1995	16.6	L5-30	1500	7.2	6-20	1995	8.3	6-20
EW-4-CBPG/SS	2660	22.2	L5-30	2000	9.6	6-20	2660	11.1	6-20
EW-5-CBPG/SS	N/A	N/A	N/A	2500	12.0	6-20	3325	13.9	6-20
EW-6-CBPG/SS	N/A	N/A	N/A	3000	14.4	6-20	3990	16.6	6-20



Duke Manufacturing Co.
2305 N. Broadway
St. Louis, MO 63102

Phone: 314-231-1130
Toll Free: 1-800-735-3853
Fax: 314-231-5074

www.dukemfg.com