

Project Name:	Location:	AIA #:
Item #:	Qty:	Model #:
		SIS #:

### TB-SERIES - STAINLESS STEEL EXTERIOR & INTERIOR



Representative, 2-door model shown

**91" WIDE MODEL**  
**TB091SL2S - 2 ROW**  
**TB091SL3S - 3 ROW**

### SPECIFICATIONS

DIMENSIONAL DATA	
1/6 Size Pans	2 Row = 26 3 Row = 39
Length in.	91 (231.1 cm)
Overall Depth in. <sup>1</sup>	2 Row = 33.5 (85.1 cm) 3 Row = 35 (88.9 cm)
Overall Height in. <sup>2</sup>	42 (106.7 cm)
Lid Open Height <sup>3</sup>	50 (127 cm)
ELECTRICAL DATA	
Horsepower <sup>4</sup>	1-1/4
Amps	17
Voltage	115/60/1
NEMA	5-20P
REFRIGERATION DATA	
Refrigerant	R-290
Charge Amount oz.	3.8 (107.7 g)
BTU	5150

### PLAN VIEW

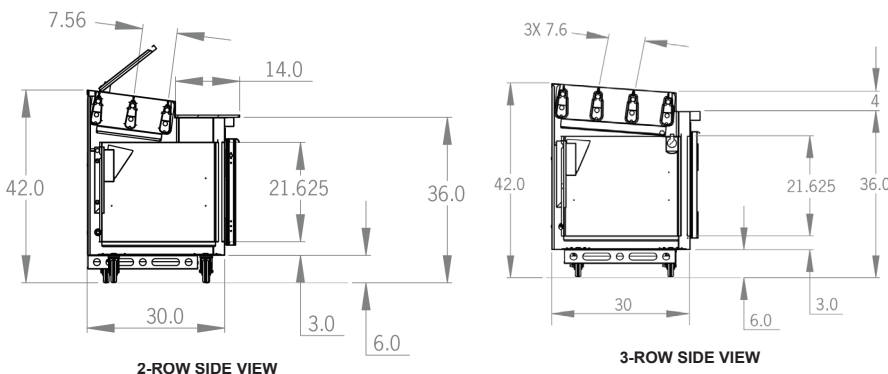
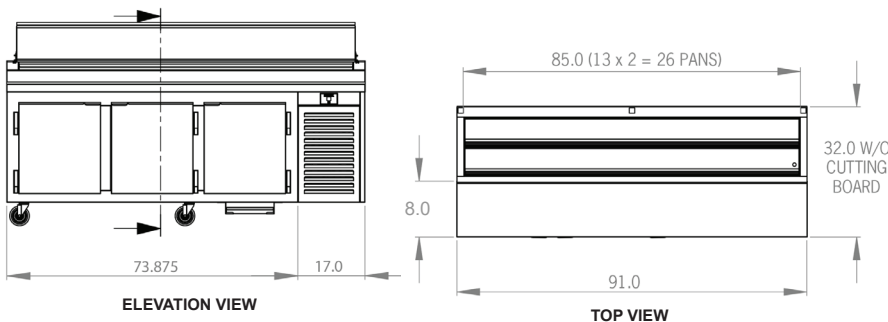

When ordering please specify:  
 Voltage, Hinging, and Options



NEMA 5-20P

1. Overall depth with either standard 14" (35.6 cm) or 8" (20.3 cm) cutting board.
2. Height shown when mounted on standard 6" (15.2 cm) high casters.
3. Height shown for hinged lift-up night cover, available for 2 row model only.
4. Based on 90°F ambient & 20°F evaporator.



Intertek



Intertek



Models listed to applicable UL, CSA, and NSF standards by an approved NRTL. Consult the factory or unit data plate for additional information.

Specifications subject to change without notice. Chart dimensions are rounded up to the nearest 1/16" (centimeters rounded up to the nearest tenth).



# TB-SERIES

## 2 & 3 ROW FULL-SIZE GLYCOL PREP TABLES



Project Name:	Location:	AIA #:	
Item #:	Qty:	Model #:	SIS #:

### REFRIGERATION SYSTEM

- Self-contained, side-mounted system uses environmentally friendly, minimal GWP R-290 refrigerant
- Front-breathing system allows zero-clearance installation
- Advanced glycol system tested to exceed NSF7 requirements
- Defrost and fan-free rail system
- High performance, balanced system operates at 34-38°F (1.1-3.3°C) to maintain consistent, food-safe temperatures for 24 hours with the lid open
- Allows overnight storage in the pan rail with the lid closed
- Specialized, clock-wise airflow design in cabinet base
- LED display for microprocessor control is water-resistant
- Easy to clean, front-facing condenser coil with removable, wire condenser filter for easy cleaning and coil protection
- Thermostatic expansion valve metering device
- High humidity evaporator coil located outside the food zone
- Hot gas evaporator defrost

### CABINET CONSTRUCTION

- Stainless steel exterior and interior
- Single microprocessor control with LED temperature display for both pan rail and cabinet base
- (1) stainless steel lift-off rail cover
- Full-length 14" deep (2 row) or 8" deep (3 row) white polycarbonate cutting board; 1/2" (1.3 cm) thick
- Exterior back and bottom are constructed of heavy gauge galvanized steel
- Horizontal finned T6 anodized aluminum chiller plates accommodate up to 8" deep third, sixth and ninth size pans (pans supplied by others)
- 7.6" (19.3 cm) chiller bar spacing
- Cabinet is insulated with an average of 2" (5.1 cm) thick high density, non-CFC foamed-in-place polyurethane
- Side, front and rear access panel for easy service and maintenance access
- A set of (4) 6" (15.2 cm) high plate casters; on adjustable channel system
- 9' (2.4 m) cord & plug provided

### DOORS

- (3) stainless steel field reversible doors, hinged left/right/right (other hinging available)
- Stainless steel handles with gasket guard
- Guaranteed for life cam-lift hinges
- Guaranteed for life workflow door handles
- Doors are self-closing with a stay-open feature
- Magnetic, snap-in door gaskets
- Optional (2) drawers in lieu of door; (holds (1) up to 6" deep 12" x 20" pan per drawer)
- Optional (3) drawers in lieu of door; (holds (1) up to 4" deep 12" x 20" pan per drawer)

### INTERIORS

- (2) adjustable, factory-installed coated wire shelves per section supported on shelf pins

### FACTORY-INSTALLED OPTIONS

- Stainless steel finished back
- Trayslides in lieu of shelves
- Full-length, removable composite (richlite brown) cutting board, 10" depth available for 3 row models
- Hinged light-up night cover (2 row models only)
- Stainless steel single or double overself
- Set of (4) 4" (10.2 cm) casters
- Set of (4) 6" (15.2 cm) legs

### WARRANTY

Both a six-year parts and labor warranty, and an additional one-year compressor parts warranty (for a total of seven years) are provided standard

CAD and/or Revit Files Available

<https://traulsen.klccad.com>

Approved by:	Approved by:	Date:
--------------	--------------	-------