



TRUE MANUFACTURING CO., INC.
RETAIL DIVISION

2001 East Terra Lane • O'Fallon, Missouri 63366-4434 • (636)240-2400
Fax (636)272-2408 • Toll Free (800)325-6152 • Intl Fax# (001)636-272-7546
Parts Dept. (800)424-TRUE • Parts Dept. Fax# (636)272-9471 • www.truemfg.com

Project Name: _____

Location: _____

Item #: _____ Qty: _____

Model #: _____

A/A #

S/S #

Model:

TVM-48SL-54-HC~VM01

Visual Merchandiser:

Slim Line Refrigerator with Hydrocarbon Refrigerant~Visual Merchandiser Version 01



TVM-48SL-54-HC~VM01

- ▶ The world's #1 manufacturer of glass door merchandisers.
- ▶ Factory engineered, self-contained, capillary tube system using environmentally friendly R290 hydro carbon refrigerant that has zero (0) ozone depletion potential (ODP), & 0.02 global warming potential (GWP).
- ▶ High capacity, factory balanced refrigeration system that maintains cabinet temperatures of 33°F to 38°F (.5°C to 3.3°C) for the best in food preservation.
- ▶ Exterior - non-peel or chip black powder coated; durable and permanent.
- ▶ Interior - attractive, white aluminum interior liner with stainless steel floor.
- ▶ Self closing doors.
- ▶ Six (6) adjustable, cantilever shelves.
- ▶ Glass door assemblies with low profile door frame.
- ▶ LED interior lighting provides more even lighting throughout the cabinet. Safety shielded.
- ▶ Entire cabinet structure is foamed-in-place using a high density, polyurethane insulation that has zero ozone depletion potential (ODP) and zero global warming potential (GWP).

Bottom mounted units feature

- ▶ "No stoop" lower shelf to maximize product visibility.
- ▶ Storage on top of cabinet.
- ▶ Easily accessible condenser coil for cleaning.

ROUGH-IN DATA

Chart dimensions rounded up to the nearest 1/8" (millimeters rounded up to next whole number). Specifications subject to change without notice.

Model	Doors	Shelves	Cabinet Dimensions (inches) (mm)			HP	Voltage	Amps	NEMA Config.	Cord Length (total ft.) (total m)	Crated Weight (lbs.) (kg)
			W	D†	H						
TVM-48SL-54-HC~VM01	2	6	47 1/8 1197	21 533	53 7/8 1368	1/4 N/A	115/60/1	2.0 N/A	5-15P	10 3.35	380 173

† Depth does not include 2" (51 mm) for door handles or 1/8" (4mm) for rear mechanical components.



APPROVALS:

AVAILABLE AT:

Model:
TVM-48SL-54-HC~VM01

Visual Merchandiser: Slim Line Refrigerator with Hydrocarbon Refrigerant~Visual Merchandiser Version 01



STANDARD FEATURES

DESIGN

- True's commitment to using the highest quality materials and factory balanced refrigeration systems provides the user with colder product temperatures, and lower utility costs in an attractive visual merchandiser that brilliantly displays packaged food and beverages.

REFRIGERATION SYSTEM

- Factory engineered, self-contained, capillary tube system using environmentally friendly R290 hydrocarbon refrigerant that has zero (0) ozone depletion potential (ODP), & 0.02 global warming potential (GWP).
- High capacity, factory balanced refrigeration system that maintains cabinet temperatures of 33°F to 38°F (.5°C to 3.3°C) for the best in food preservation.
- State of the art, electronically commutated evaporator and condenser fan motors. ECM motors operate at higher peak efficiencies and move a more consistent volume of air which produces less heat, reduces energy consumption and provides greater motor reliability.
- Bottom mounted condensing unit positioned for easy maintenance. "No stoop" lower shelf maximizes visibility by raising merchandised product to higher level.

CABINET CONSTRUCTION

- Exterior - non-peel or chip black powder coated; durable and permanent.
- Interior - attractive, white aluminum liner with stainless steel floor.
- Insulation - entire cabinet structure is foamed-in-place using a high density, polyurethane insulation that has zero ozone depletion potential (ODP) and zero global warming potential (GWP).
- Welded, heavy duty steel frame rail, black powder coated for corrosion protection.
- Frame rail fitted with leg levelers.
- Door sign decal. Variety of decal options available.

DOORS

- Glass door assemblies with low profile door frame.
- Each door fitted with 12" (305 mm) long handle.
- Self closing doors.

SHELVING

- Six (6) adjustable, cantilever shelves. 21 7/32" L x 14"D (541 mm x 356 mm)
- Shelf support pilasters made of same material as cabinet interior; shelves are adjustable on 1" (26 mm) increments.

LIGHTING

- LED interior lighting provides more even lighting throughout the cabinet. Safety shielded.

MODEL FEATURES

- Evaporator is epoxy coated to eliminate the potential of corrosion.
- See our website www.truemfg.com for latest color and sign offerings.
- Listed under NSF/ANSI Standard 7 for the storage and/or display of packaged or bottled product.

ELECTRICAL

- Unit completely pre-wired at factory and ready for final connection to a 115/60/1 phase, 15 amp dedicated outlet. Cord and plug set included.



RECOMMENDED OPERATING CONDITIONS

- Designed to operate in an environment where temperature and humidity do not exceed 80°F (27°C) and 55% relative humidity.

OPTIONAL FEATURES/ACCESSORIES

Upcharge and lead times may apply.

- 6" (153 mm) standard legs
- 6" (153 mm) seismic/flanged legs
- 2 1/2" (64 mm) diameter castors
- Black interior
- Stainless Interior
- Additional shelves
- Floor rack
- Pricing strips

PLAN VIEW

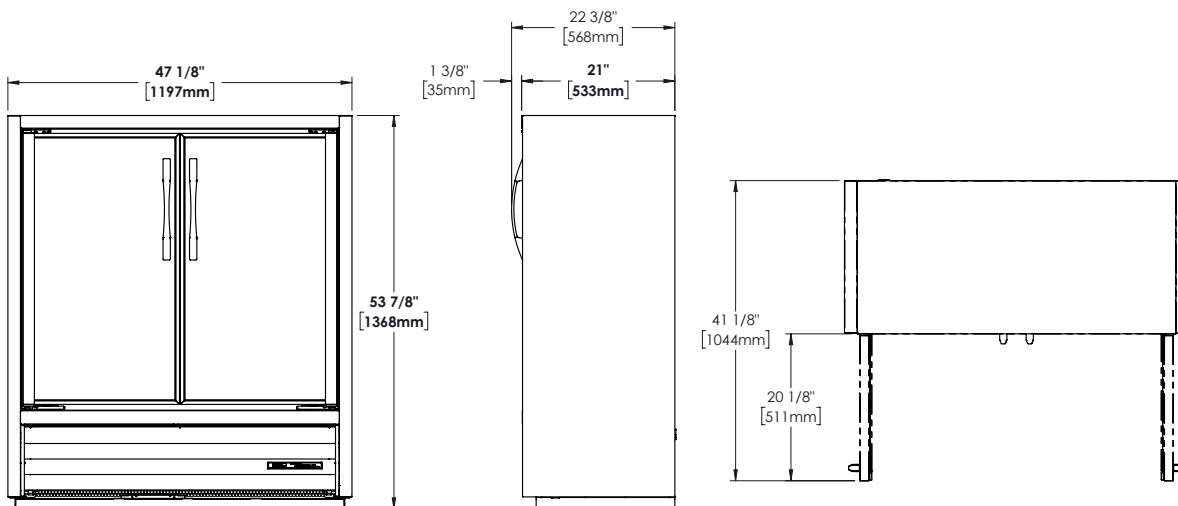

METRIC DIMENSIONS ROUNDED UP TO THE NEAREST WHOLE MILLIMETER
SPECIFICATIONS SUBJECT TO CHANGE WITHOUT NOTICE

KCL	Model	Elevation	Right	Plan	3D	Back
	TVM-48SL-54-HC~VM01					

TRUE MANUFACTURING CO., INC.

2001 East Terra Lane • O'Fallon, Missouri 63366-4434 • (636)240-2400 • Fax (636)272-2408 • Toll Free (800)325-6152 • Intl. Fax# (001)636-272-7546 • www.truemfg.com