



Project \_\_\_\_\_

Item No. \_\_\_\_\_

Quantity \_\_\_\_\_

# THE Fire™



## EXTERIOR CONSTRUCTION

- Powder coated (RAL-3020 - Traffic Red), corrosion-resistant steel outer wrap and door
- 430 stainless steel construction

## INTERIOR CONSTRUCTION

- 430 stainless steel interior
- Double wall insulated cooling construction

## STANDARD FEATURES

- Fits up to a 14-inch thin or thick dough pizza
- Integral catalytic converter for ventless operation
- Removable bottom access panel for easy cleaning
- Independent top and bottom electronic temperature control
- Top and bottom convection motors
- 6 preset timers
- Includes plug and cord (6 ft. nominal)
- Warranty – 1 year parts and labor

## COMES WITH STANDARD ACCESSORIES

- 1 Stainless Steel Paddle
- 2 14-inch Aluminum Pizza Screens

## COLOR OPTIONS (call for availability)

- Standard Color: Traffic Red (RAL-3020)
- Yellow Green (RAL-6018)
- Pure White (RAL-9010)
- Jet Black (RAL-9005)
- Blue (RAL-Custom TurboChef Blue)
- Stainless Steel

## PERFORMANCE

The TurboChef Fire provides the artisan-hearth style pizza experience anywhere. Cooking at 842°F/450°C, the Fire can cook 14-inch fresh dough pizzas in as little as 90 seconds. The oven has a small footprint and is ventless, so it can be placed virtually anywhere without type I or type II ventilation.

## VENTILATION

- UL (KNLZ) listed for ventless operation.<sup>†</sup>
- EPA 202 test (8 hr):
  - Product: Pepperoni Pizzas
  - Results: 0.48 mg/m<sup>3</sup>
  - Ventless Requirement: <5.00 mg/m<sup>3</sup>
- Internal catalytic filtration to limit smoke, grease, and odor emissions.

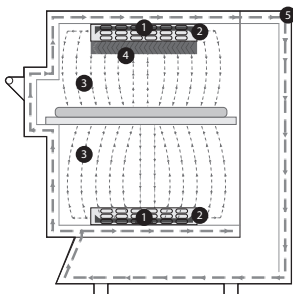

1. Convection Fans
2. Heaters
3. Convection Airflow
4. Catalytic Converter
5. Insulated Cooling

This product conforms to the ventilation recommendations set forth by NFPA96 using EPA202 test method.

<sup>†</sup> Ventless certification is for all food items except for foods classified as "fatty raw proteins." Such foods include bone-in, skin-on chicken, raw hamburger meat, raw bacon, raw sausage, steaks, etc. If cooking these types of foods, consult local HVAC codes and authorities to ensure compliance with ventilation requirements.

Ultimate ventless allowance is dependent upon AHJ approval, as some jurisdictions may not recognize the UL certification or application. If you have questions regarding ventless certifications or local codes please email [ventless.help@turbochef.com](mailto:ventless.help@turbochef.com)

TurboChef reserves the right to make substitutions of components or change specifications without prior notice.

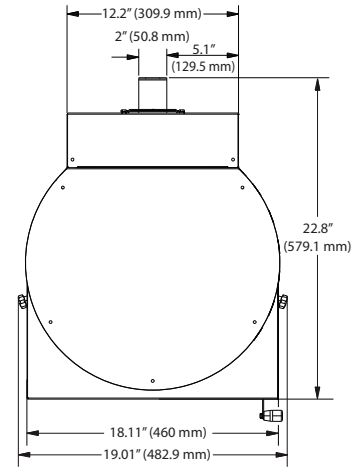
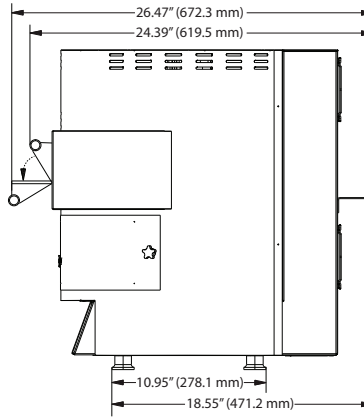
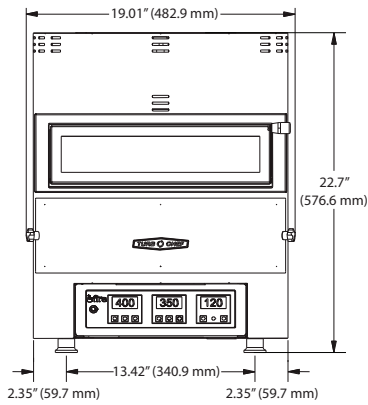

DIMENSIONS		
Height	21.70"	551 mm
with legs	22.70"	576.6 mm
Width	19.01"	482.9 mm
Depth (footprint)	18.55"	471.2 mm
with door closed	24.39"	619.5 mm
with door open	26.47"	672.3 mm
Weight	75 lb.	34 kg
Cook Chamber		
Width	14.75"	375 mm
Depth	14.75"	375 mm
Wall Clearance (Oven not intended for built-in installation)		
Top	2"	51 mm
Sides	2"	51 mm
Back	0"	0 mm

ELECTRICAL SPECIFICATIONS - SINGLE PHASE		
FRE-9600-1: Traffic Red (RAL 3020) - North America		
FRE-9600-2: Yellow Green (RAL 6018) - North America		
FRE-9600-4: Pure White (RAL 9010) - North America		
FRE-9600-5: Jet Black (RAL 9005) - North America		
FRE-9600-6: Blue (Custom) - North America		
FRE-9600-31: Stainless Steel - North America		

Voltage	208 / 240 VAC	 NEMA 6-30P
Watts	3700 / 4800 W	
Frequency	50 / 60 Hz	
Breakers	30 Amp	
Input Current	17.5 - 20.5 Amp	

FRE-9600-7-UK: Traffic Red (RAL 3020) - Europe/Asia/South America		
FRE-9600-8-UK: Yellow Green (RAL 6018) - Europe/Asia/South America		
FRE-9600-10-UK: Pure White (RAL 9010) - Europe/Asia/South America		
FRE-9600-11-UK: Jet Black (RAL 9005) - Europe/Asia/South America		
FRE-9600-12-UK: Blue (Custom) - Europe/Asia/South America		
FRE-9600-32-UK: Stainless Steel - Europe/Asia/South America		

Voltage	230 VAC	 IEC 60309
Watts	4500 W	
Frequency	50 / 60 Hz	
Breakers	32 Amp	
Input Current	17.5 - 20.5 Amp	

FRE-9600-13-AK: Traffic Red (RAL 3020) - Australia		
FRE-9600-14-AK: Yellow Green (RAL 6018) - Australia		
FRE-9600-16-AK: Pure White (RAL 9010) - Australia		
FRE-9600-17-AK: Jet Black (RAL 9005) - Australia		
FRE-9600-18-AK: Blue (Custom) - Australia		
FRE-9600-33-AK: Stainless Steel - Australia		

Voltage	230 VAC	 Clipsal 56PA320
Watts	4500 W	
Frequency	50 / 60 Hz	
Breakers	32 Amp	
Input Current	17.5 - 20.5 Amp	

**ELECTRICAL SPECIFICATIONS - MULTI PHASE**

FRE-9600-25-EW: Traffic Red (RAL 3020) - Europe/Asia/South America		 IEC 309, 5-pin
FRE-9600-26-EW: Yellow Green (RAL 6018) - Europe/Asia/South America		
FRE-9600-28-EW: Pure White (RAL 9010) - Europe/Asia/South America		
FRE-9600-29-EW: Jet Black (RAL 9005) - Europe/Asia/South America		
FRE-9600-30-EW: Blue (Custom) - Europe/Asia/South America		
FRE-9600-35-EW: Stainless Steel - Europe/Asia/South America		

Voltage	380 - 415 VAC
Watts	4510 / 4940 W
Frequency	50 / 60 Hz
Breakers	20 Amp
Input Current	11.5/1.4/9.2 Amp

FRE-9600-19-AU: Traffic Red (RAL 3020) - Australia	
FRE-9600-20-AU: Yellow Green (RAL 6018) - Australia	
FRE-9600-22-AU: Pure White (RAL 9010) - Australia	
FRE-9600-23-AU: Jet Black (RAL 9005) - Australia	
FRE-9600-24-AU: Blue (Custom) - Australia	
FRE-9600-34-AU: Stainless Steel - Australia	

Voltage	380 - 415 VAC	 Clipsal 5-pin
Watts	4510 / 4940 W	
Frequency	50 / 60 Hz	
Breakers	20 Amp	
Input Current	11.5/1.4/9.2 Amp	

**SHORT FORM SPECIFICATIONS**

Provide TurboChef Fire countertop oven. The Fire oven cooks artisan and traditional style pizzas up to 14 inches. The Fire oven allows an operator to independently control the top and bottom temperature in the cavity which ensures precise delivery of top and bottom heat. Additionally, it features 6 preset timers. The Fire oven uses TurboChef catalytic technology in order to eliminate smoke and grease during operation, allowing the oven to be UL®-certified for ventless operation. The exterior and interior are constructed with 430 stainless steel. The outer wrap and door are available in six powder-coated colors (red, green, black, white, or blue).

**SHIPPING INFORMATION**

All ovens are packaged in a triple-wall corrugated box banded to a wooden skid.
Box size (including skid): 34" (864 mm) x 30" (762 mm) x 34" (864 mm)
Item class: 110 NMFC #26710 HS code 8419.81
Approximate boxed weight: 100 lb. (45 kg)
Minimum entry clearance required for box: 34.5" (876 mm)

**TurboChef Global Operations**  
 2801 Trade Center Drive / Carrollton, Texas 75007 USA  
 US: 800.90TURBO (800.908.8726) / International: +1 214.379.6000  
 Fax: +1 214.379.6073 / turbochef.com