

Mobile Ice Cream Counter

Standard Features

FRAME: Featuring frameless construction utilizing 16 gauge stainless steel formed end panels with top and bottom horizontal members of 16 gauge stainless steel.

CASTERS: Heavy duty 5" diameter plate casters with gray rubber tires. Brake models to be supplied on all casters.

TOP: 14 gauge stainless steel with 2" turndown on all sides and sound deadening applied between top and frame.

FRONT BODY PANEL: Removable stainless steel or plastic laminate front panel.

CONDENSING UNIT: R-404A high temperature hermetically sealed with expansion valve and pressure switch operation.

ICE CREAM DISPENSER: Stainless steel interior liner with 1/2" drain in bottom. Self leveling lowerator dispensing mechanism for prepackaged ice cream items. Self contained condensing unit.

DISPENSING LIDS: Stainless steel bi-fold covers with locking mechanism (lock by others).

STAINLESS STEEL SPECIFICATION: All stainless steel to be type 304 with number 4 finish.

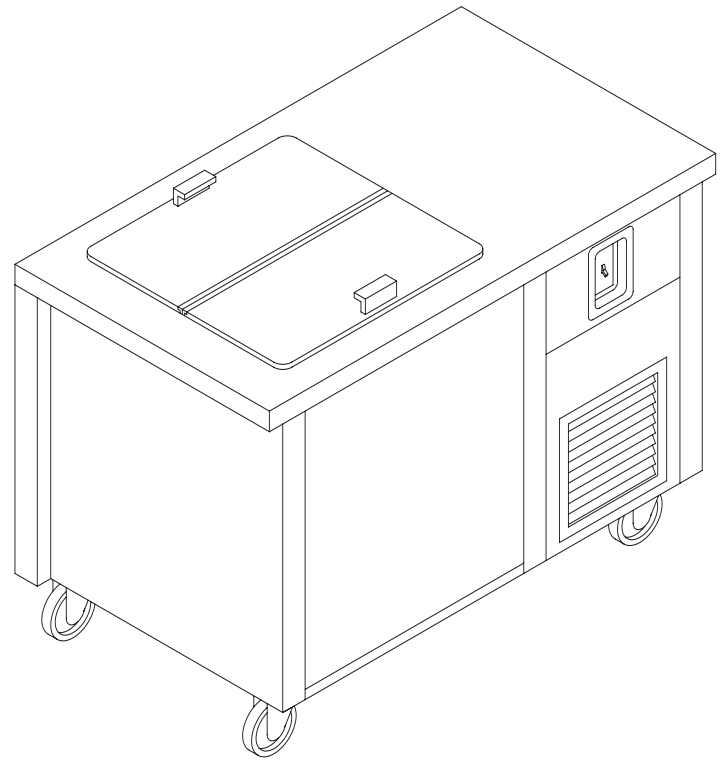

MODEL	LENGTH	CAPACITY	HP	VOLTS	PHASE	AMPS	NEMA CORD/CAP	APPROX. SHIP WEIGHT
MCT-ID3	50"	-	1/3	120	1	6.0	NEMA 5-15P	460 lbs



2320 Peyton Houston, Texas 77032
 Phone 281-442-8001 Toll Free: 888-955-5463 Fax: 281-442-3351 www.mod-u-serve.com

Mobile Ice Cream Counter

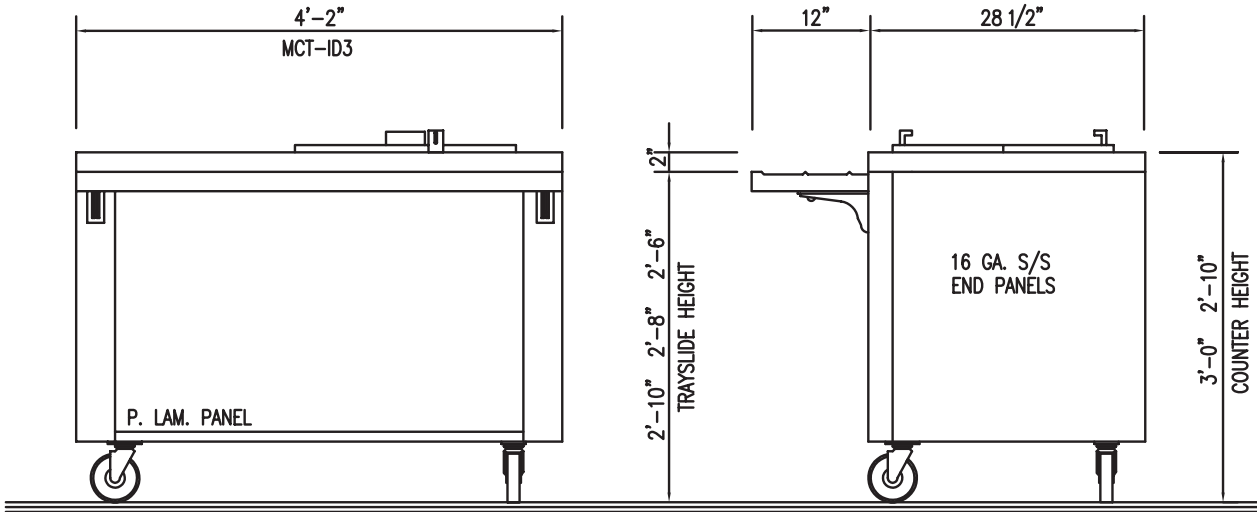

Optional Features

FRONT BODY PANEL: Ceramic tile front panel.

TRAYSLIDE: Stainless steel or Corian® trayslide mounted on fold down brackets. Stainless steel tubular trayslide also available, on fold down brackets.

LEGS: 6" adjustable stainless steel legs in lieu of casters.

SNACK RACK: 16 gauge stainless steel slanted snack rack.

DUAL SERVICE TRAYSLIDE: Dual sided stainless steel or Corian® trayslide mounted on fold down brackets.

OPTIONAL COUNTER/TRAYSLIDE HEIGHT:

Elementary schools – 34" counter / 30" trayslide

Middle School – 34" counter / 32" trayslide

High School – 36" counter / 34" trayslide

ADDITIONAL WARRANTY: Additional 12 month limited warranty on parts and labor.

For options / accessories / modifications not shown, please contact factory.

Mod-U-Serve reserves the right to modify specifications or discontinue models without notice or incurring obligation.



2320 Peyton Houston, Texas 77032

Phone 281-442-8001 Toll Free: 888-955-5463 Fax: 281-442-3351 www.mod-u-serve.com

MUS.15 11/05