

ITEM #



ENCLOSED FACADE Series Wood-Fired Oven, Brick, with Enclosed Facade EF90W

Experience a level of quality that is Italian-inspired, but manufactured for the needs of North American restaurants. Marra Forni brick ovens combine traditional artisanal workmanship, such as a full refractory brick enclosure for outstanding performance, with modern manufacturing technology and design innovation. Each oven is hand-made, brick-by-brick, using the same time-proven techniques that masons have used for generations. As functional art for the front of the house, or built into a wall or other structure for ease of cleaning, each oven is completely customizable for specific needs and decors.

Each model features our unique Marra Stone® stone-hearth cooking surface as its heart. This proprietary refractory brick surface includes volcanic material, for outstanding cooking results as well as constant temperatures for consistency. Insulated construction allows heat to be absorbed and retained in the oven cavity for improved efficiency.

Marra Forni Enclosed Facade series ovens are designed to be built directly into a wall or other enclosure, for a flush and seamless appearance. Combined with our standard traditional brick oven interior, this provides a unique oven solution, offering all of the performance advantages of our traditional Neapolitan ovens with a fully wall-integrated front-of-house appearance. These ovens are approved and certified "VPN" (*Vero Pizza Napoletana*), proudly showing their adherence to strict internationally-recognized standards governing oven construction and suitability for the Neapolitan-style pizza cooking process. Gas primary heat provides efficiency, while wood auxiliary heat imparts traditional flavor profiles and enhances cooking adjustability.



Standard Features

- Approved and certified "VPN" (*Vero Pizza Napoletana*) for adherence to traditional construction and pizza baking techniques pioneered in Naples, Italy
- MarraStone® stone hearth deck is of a refractory brick that includes volcanic material. This deck is both durable and highly porous, and is capable of maintaining cooking temperatures from 200-950°F (93-510°C) for consistent high-volume production
- Enclosed facade design permits installation directly into a wall for a flush appearance
- Superior cooking performance and recovery based upon natural convective airflow within the oven chamber, and the heat retention of custom formulated refractory bricks
- Wood-burning heating provides traditional cooking flavors
- Integrated "eyebrow" exhaust duct at the loading/unloading entrance is integrated into the structure of the oven dome, greatly reducing emissions into the room while enhancing staff visibility of oven interior
- 1-1/4" (32mm)-thick black granite ledge
- Removable front door
- Painted matte black steel front facade
- Heavy duty black powder-coated steel stand
- Unfinished cement dome exterior
- Manufactured in the U.S.A.

Cooking Capacity (typical)

- 8" (200mm) pizzas: 8
- 10" (250mm) pizzas: 7
- 12" (300mm) pizzas: 6
- 16" (400mm) pizzas: 2

Production capacity varies depending upon type of food product being cooked, food preparation and cooking temperature.

Total Cooking Surface 6.85 sq. ft. (0.64 sq. m)

Cooking Deck Diameter 35-3/8" (900mm)



Intertek **Intertek**

CSA 1.8 | UL 2162 | ULC/ORD C2162 | NSF/ANSI 4

Configuration Options (Check all that apply)

Fuel Type

- Wood-Fired

Options

- Direct Ventilation (quoted separately)
- Exhaust Fan with Variable Speed Fan Control
- Integrated Fan Interlock
- Stainless Steel Facade
- Stainless Steel Stand
- Shelf Delete (for improved burner access)
- Interior Light Box
- Painted Exterior (instead of standard unfinished exterior)
- Base Enclosure (Side Panels)
- Base Enclosure (Full Skirt Enclosure)
- Base Trim Kit

Accessories

- Dough Tray
- Dough Tray Lid(s)
- Dough Tray Dolly
- Standard Peel Tool Kit
- Deluxe Peel Tool Kit
- Wall Mounted Tool Rack

ENCLOSED FACADE Series
EF90W

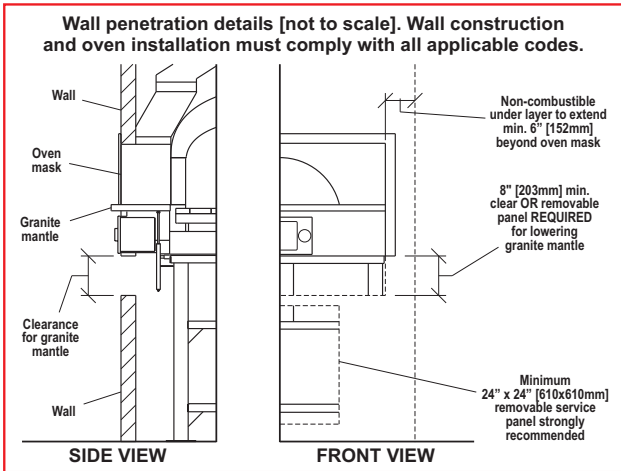
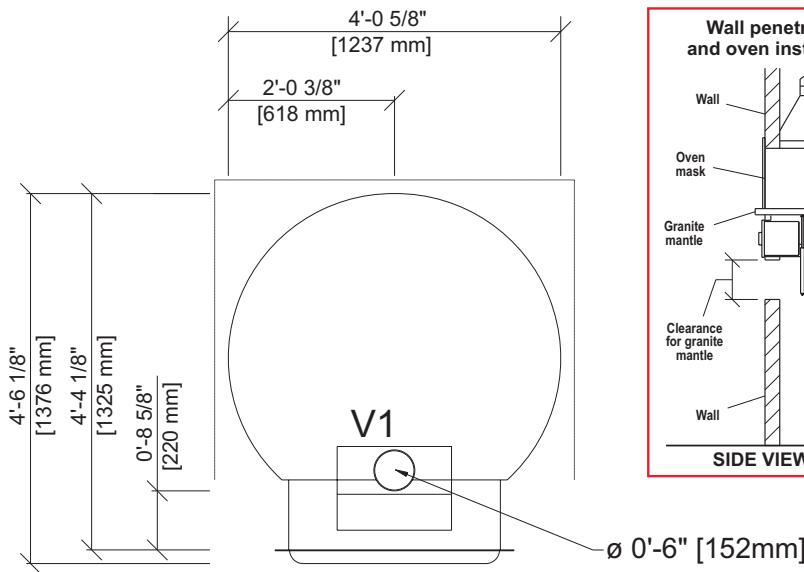
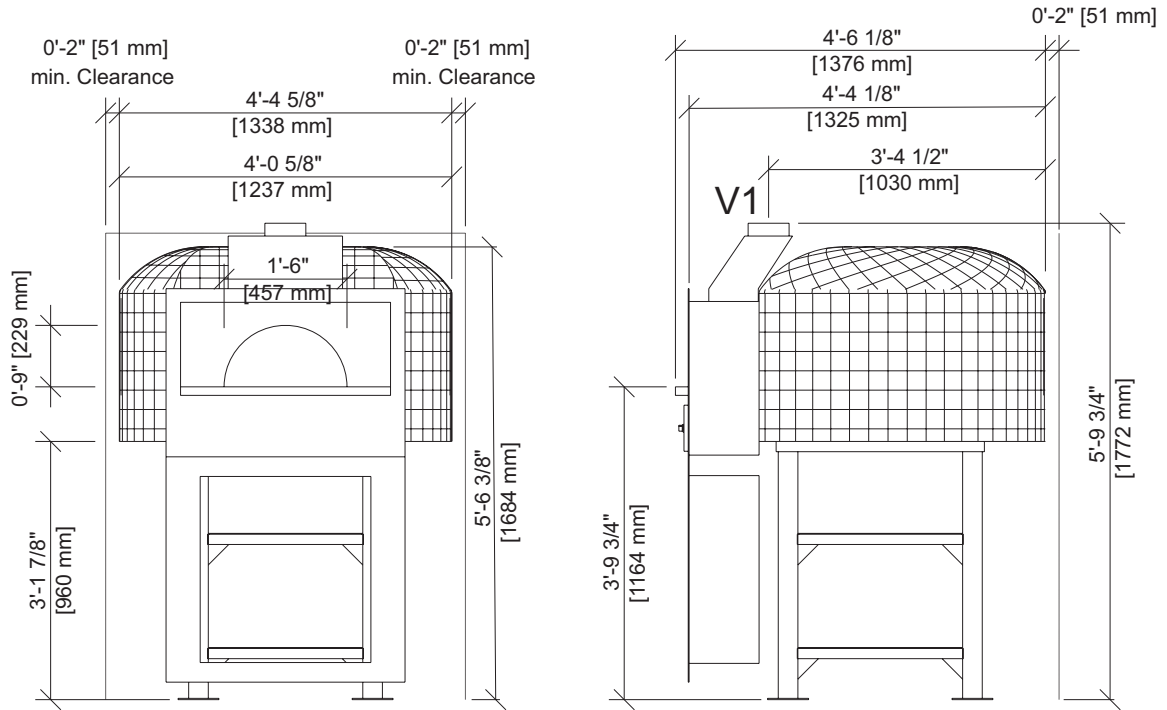

Solid fuel loading (through front door) **Wood**
 Volume and wood type is dependent on desired flavor profile and baking temperature

V Ventilation connection
 8" (203mm) dia.

For utility loads and connection details, refer to Page 3 of this spec sheet.

All specifications are subject to change without notice, based on Marra Forni's commitment to ongoing product development and improvement measures. Ovens are designed only for the cooking of manufacturer-approved food products in commercial and institutional settings, and should not be used for any other purpose.

ENCLOSED FACADE Series

EF90W



Dimensional Information

- Minimum clearance: 2" (51mm) on all sides and rear from combustible surfaces, 0" (0mm) from non-combustible surfaces, 18" (450mm) side clearance recommended for service access
- Exterior: (H x W x D): 69-3/4" x 48-5/8" x 54-1/8" (1773 x 1235 x 1375mm)
- Shipping: (H x W x D): 82" x 73" x 63" (2083 x 1854 x 1600mm)
- Weight: 1,650 lbs. (748 kg)
- Crated Weight: 1,950 lbs. (885 kg)
- Freight Class: 77.5, shipped LTL

Ventilation Connection Requirements

Connection	Volume	Static Pressure
6" (152mm)	150 CFM	0.01" W.C.
round collar	255 m ³ /h	2.5 Pa

Oven may be installed with an approved direct vent system, or an approved Type 1 exhaust hood system. Ventilation system must comply with all applicable local and national codes.

If direct ventilation is desired, a Marra Forni-designed optional vent system is available as an option and is strongly recommended. This option also requires the exhaust fan (with variable speed fan control) option.

If not using a Marra Forni-supplied direct ventilation connection, determining correct ventilation and code compliance is the responsibility of others.

Specification

EF90W Item # _____

Unit will be an ETL-listed Marra Forni EF90W freestanding, wood heated brick oven, intended for cooking and baking pizza and other approved food products.

Unit heating will be provided by wood burning.

Unit will feature a stone hearth cooking deck composed of a refractory brick composition, including volcanic material, to provide and maintain cooking temperatures up to 950°F (510°C).

Unit will feature an enclosed facade design for a flush wall installation.

Unit cooking area will measure 35-3/8" (900mm) in diameter. Door opening will measure 18" (457mm) in width and 9" (229mm) in height.

Unit will feature a brick interior for superior heat retention and distribution within the cooking chamber.

Unit will feature an unfinished cement dome exterior.

Unit will include a removable front door.

Unit will include an oven mantle featuring a 1-1/4" (32mm)-thick black granite ledge.

Unit will include a black powder-coated steel stand and painted matte black steel front facade.

Unit will be approved and certified "VPN" (*Vero Pizza Napoletana*) for adherence to internationally-recognized standards governing oven construction and suitability for the traditional Neapolitan-style pizza cooking process.

Unit will be manufactured in the U.S.A. and comply with all applicable FTC requirements for this status.