



Project _____
 AIA # _____ SIS # _____
 Item # _____ Quantity _____ C.S.I. Section 114000



DEALERS CHOICE COMPACT UNDERCOUNTERS

ULT SERIES

Freezer Compact Undercounter

ULT48



STANDARD PRODUCT FEATURES

- Stainless Steel Exterior Top, Sides & Doors
- Anodized Aluminum Interior
- Front Breathing Self-Contained Refrigeration System
- Environmentally Friendly R-448A Refrigerant
- Self-Closing Doors with Stay-Open Feature at 105 Degrees
- Anodized Aluminum Interior Door Liner
- Electronic Control
- Two (2) Powder Coated Shelves Per Door, Mounted on Pilasters
- Automatic Non-Electric Condensate Evaporator
- Magnetic Snap-In EZ-Clean Door Gasket(s)
- 8' (2.4 m) NEMA Cord & Plug Attached
- Set of Four (4) 4" Casters
- 3-Year Parts & Labor Warranty
- 2-Years Additional Compressor Parts Warranty

ACCESSORIES & OPTIONS (*field installed)

- CK20 (four 6" (15.2 cm) high casters for 48" models)
- CK24 (four 3-1/2"(8.9 cm) high casters for 48" models)
- CK26 (four 2-3/4" (6.9 cm) high casters for 48" models)
- LK4 (four 6" (15.24 cm) high legs for 48" models)
- SHELF48 UPPER (upper shelf for 48" models)
- SHELF48 LOWER (lower shelf for 48" models)
- CU48TOP-BSWO (heavy gauge stainless steel top with 4" (10.2 cm) backsplash 48")
- Optional accessory kits shipped separately for field installation



This unit is listed to the applicable UL, CSA and NSF Standards by an approved NRTL. Consult the factory or unit's data plate for approval information.

AVAILABLE CONFIGURATIONS

27", 48", 60" Wide Models

Model	Door Style	Hinging
ULT48-LR	Two Hinged Solid Doors	Left/Right
ULT48-LL	Two Hinged Solid Doors	Left/Left
ULT48-RR	Two Hinged Solid Doors	Right/Right

FACTORY INSTALLED OPTIONS

- Stainless Steel Finished Back

Approved by _____ Date _____ Approved by _____ Date _____



MODELS:

ULT48-LR, -LL, -RR

CLICK
TRANSFER
For KCL CADalog Website

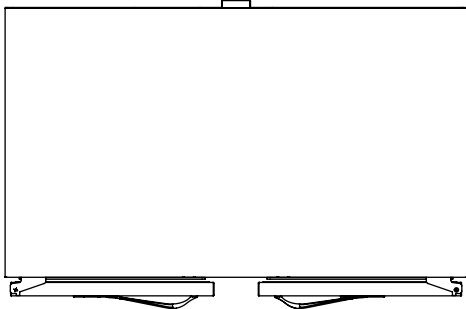

TOP VIEW

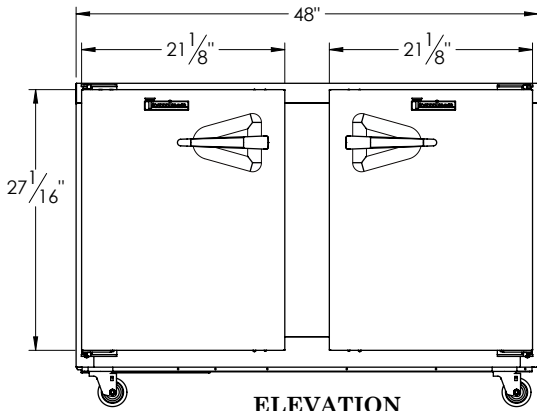
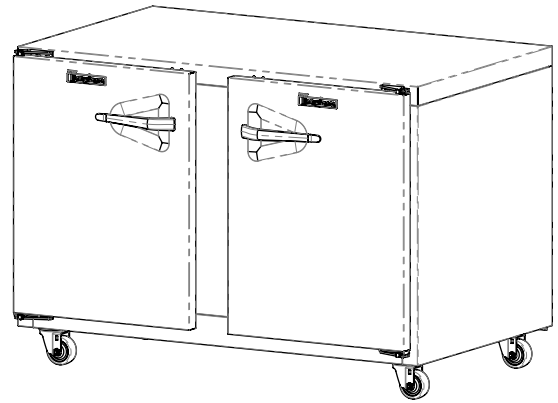

ELEVATION

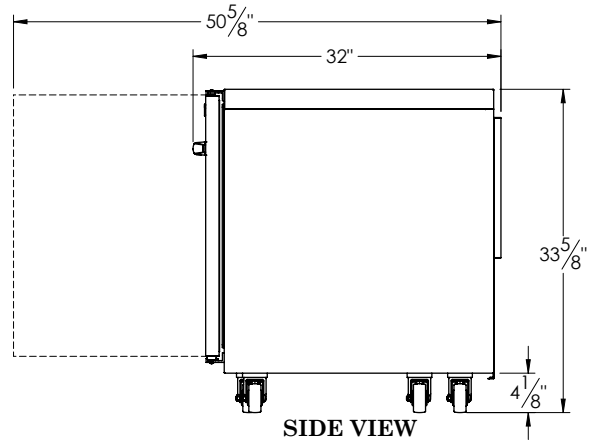

SIDE VIEW



ULT SERIES

Freezer Compact Undercounter

DEALERS CHOICE COMPACT UNDERCOUNTERS

MODELS

Door Models: ULT48-LR, -LL, -RR

EQUIPMENT SPECIFICATIONS

MODELS	ULT48-__
CABINET DIMENSIONAL DATA	
Net Capacity cu. ft.	13.56 (383 l)
Width cabinet in.	48 (112 cm)
Width door in.	21 1/8 (53.7cm)
Depth - door open 90° in.	50 3/8 (128.6 cm)
Clear door opening in.	18 (45.7 cm)
# of doors	2
# of shelves	4
Total shelf Area sq. ft.	10.3 (.96 m)
ELECTRICAL DATA &	
Voltage Plug	115/60/1 NEMA 5-15P (attached)
Full Load Amps	8.0
MDEC ¹	4.15 kWh/day
REFRIGERATION DATA	
Refrigerant	R-448A
Refrigerant Amount oz.	12 (340 g)
BTU ² /HR H.P.	1740 1/2 HP
SHIPPING DATA	
Width Crated in.	69 (175 cm)
Volume Crated cu. ft.	77 (2180 l)
Weight lbs. (kg) - Crated	355 (161)

CONSTRUCTION, HARDWARE, INSULATION

Cabinet exterior front, one piece sides, and doors are constructed of heavy gauge stainless steel. Cabinet interior and door liners are constructed of anodized aluminum. The exterior cabinet back and bottom are constructed of galvanized steel.

Door self-closes at less than 90 degrees and also includes a stay open feature at 105 degrees. Gasket profile and material simplify cleaning and increase overall gasket life. Both the cabinet and door(s) are insulated with an average of 2" (5 cm) thick high density, non-CFC, foamed in place polyurethane.

REFRIGERATION SYSTEM

A balanced, rear mounted, front breathing, self-contained refrigeration system using environmentally-friendly R-448A refrigerant is provided. It features a TXV valve, air cooled 1740 BTU, 1/2 HP, hermetic compressor, a forced air evaporator coil and a non-electric condensate evaporator. An 8' (2.4m) NEMA cord and plug is provided. Standard operating temperature for freezer models is 0° to -5°F (-17° to -16°C).

CONTROLLER

An electronic digital control is supplied standard. It includes a 3-Digit LED display, and a Fahrenheit or Celsius temperature scale display capability.

INTERIOR

Standard interior arrangements include two (2) powder coated wire shelves per door, mounted on pilasters. These are adjustable in 1/2" (1.27 cm) increments, allowing for a minimum of 1-1/2" (3.81 cm) spacing between shelves.

DOMESTIC WARRANTY

Both a three year parts and labor warranty and a five year compressor parts warranty (self-contained models) are provided standard.

NOTES:

- MDEC = Maximum Daily Energy Consumption
 - Compressor BTU based on a 90° F (32° C) degree ambient and 20° (-6° C) degree evaporator.
- When ordering please specify: voltage, hinging and optional accessories.

CONTINUED PRODUCT DEVELOPMENT MAY NECESSITATE SPECIFICATION CHANGES WITHOUT NOTICE.

Approved by _____ Date _____ Approved by _____ Date _____