

# SANDWICH UNIT REFRIGERATOR

## Model: SW32N8-D

Natural Refrigerant R-290 Model

### 32" Standard Top Sandwich Unit Refrigerator with Drawers - 8 Pans

Stainless steel front, top and end panels, aluminum back and interior.



## Options and Accessories

(upcharge and lead times may apply)

|                                |                            |
|--------------------------------|----------------------------|
| Stainless steel interior       | Drawer locks               |
| Stainless steel back           | Front breathing            |
| Overshelves (single or double) | Rear mounted cutting board |
| Adjustable legs                | Composite cutting board    |
| Optional caster sizes          | Crumb catcher              |
| Flat lid                       | Modified pan opening       |
| Vision panel lid               |                            |

Consult factory for other model configurations, options and accessories.

**Continental**<sup>®</sup>  
Refrigerator



Project Name:

Model Specified:

Location:

Item No:

Quantity:

AIA #:

SIS #:

## Standard Model Features

### REFRIGERATION SYSTEM

Performance rated refrigeration system

Natural, environmentally safe, high efficiency R-290 refrigerant<sup>1</sup>

Unique air flow distribution allows pan product to maintain 33° - 41°F

Automatic, hot gas condensate evaporator

Non-corrosive, plasticized fin evaporator coil

Easily serviceable, back mounted compressor

### CABINET ARCHITECTURE

2" non-CFC polyurethane foam insulation

Smooth, polished chrome drawer handles

Stainless steel roll out drawers

Magnetic snap in Santoprene™ drawer gaskets

12" deep, full length nylon cutting board

Insulated lid

Completely enclosed, vented and removable case back

5" casters

### MODEL FEATURES

Electronic control, off-cycle defrost

(8) ½ size recessed pans, 4" deep

Off-cycle defrost

Removable interior tub below pans

<sup>1</sup> R-290 refrigerant meets all federal and state regulatory requirements.

APPROVAL:

# Model Specifications

## DIMENSIONAL DATA

|  |                  |
|--|------------------|
| Net Capacity (cubic feet)                                | 9.0 (253 l)      |
| 1/6 Size Pans (4" deep)                                  | 8                |
| Width, Overall (inches)                                  | 32 (813 mm)      |
| Depth, Overall (inches)<br>(including handles & bumpers) | 32 3/16 (818 mm) |
| Depth, Cutting Board (inches)                            | 12 (305 mm)      |
| Height, Overall (inches)<br>(including 5" casters)       | 42 1/4 (1073 mm) |
| Number of Drawers (two tier)                             | 2                |

## REFRIGERANT DATA

|                               |      |
|-------------------------------|------|
| Condensing Unit Size (H.P.)   | 1/5  |
| R-290 Refrigerant Charge (oz) | 3.4  |
| Capacity (BTU per hour)*      | 1390 |

\* Rating @ +25°F evaporator, 90°F ambient

## ELECTRICAL DATA

|  |                     |
|--|---------------------|
| Voltage (International)                        | 115/60/1 (220/50/1) |
| Total Amps (International)                     | 3.1 (1.6)           |
| 10 ft. Cord/Plug [attached]<br>(International) | Yes<br>(No)         |

## SHIPPING DATA

|                          |                  |
|--------------------------|------------------|
| Weight (pounds)          | 300 (137 kg)     |
| Height - Crated (inches) | 43 1/4 (1099 mm) |
| Width - Crated (inches)  | 40 (1016 mm)     |
| Depth - Crated (inches)  | 37 1/4 (946 mm)  |

## DRAWER PAN CONFIGURATIONS

**Two Tier:** (1) 12 x 20 x 6 pan per drawer  
or (1) 1/2 size x 6 & (2) 1/3 x 6 pans per drawer

Figures in parentheses reflect metric equivalents rounded to the nearest whole unit.



Equipped with one NEMA-5-15P Plug  
(varies by country)

**Continental**  
Refrigerator

Toll-Free: 800-523-7138  
Phone: 215-244-1400  
Fax: 215-244-9579

539 Dunkserry Road  
Bensalem, PA 19020  
[www.continentalrefrigerator.com](http://www.continentalrefrigerator.com)

Due to our continued efforts in developing innovative products, specifications subject to change without notice.



PROUDLY  
DESIGNED & ASSEMBLED  
IN THE U.S.A.

© Copyright 2021. Continental Refrigerator.  
A Division of National Refrigeration & Air Conditioning Products, Inc.

# Model Plan Views

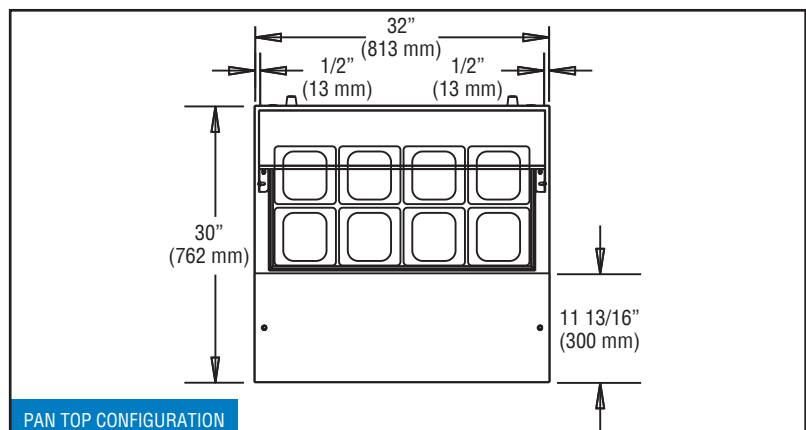
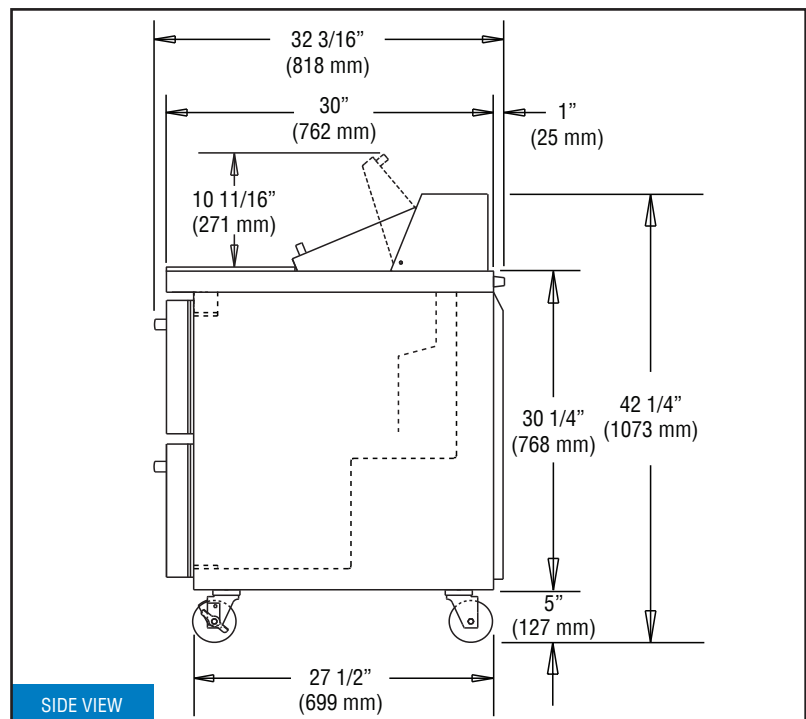
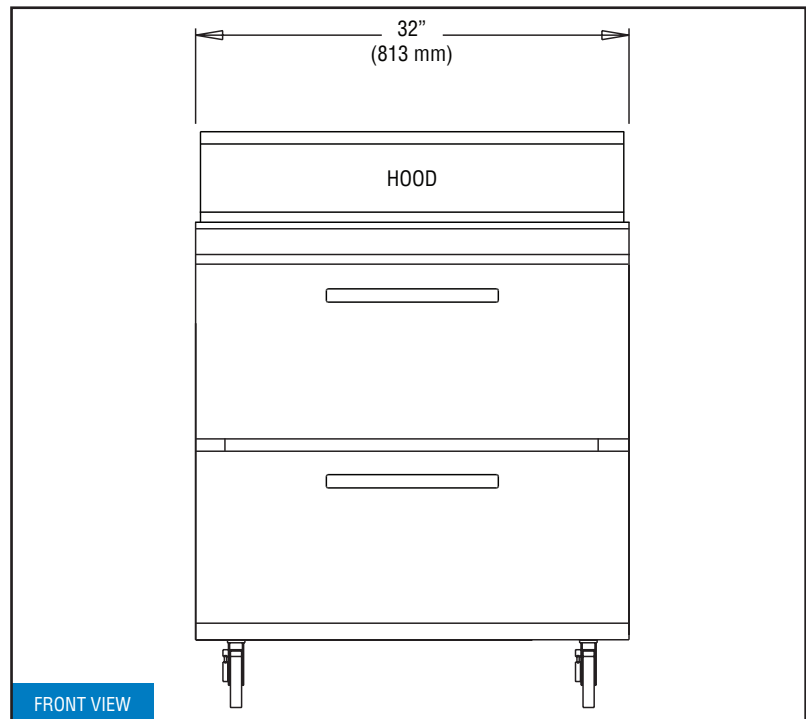

REVISED: 12/6/25