



Founded in 1946

Project: _____

Items: _____

Quantity: _____

Approval: _____

Date: _____

Vending Merchandiser Kiosk Grab & Go Cart w/ Double-Sided Canopy



Features:

- Constructed of all welded stainless steel, specifically engineered to effectively support magnetic branding and logos
- 1 Year Warranty
- (4) WHPL-5K Polypropylene tubs provided
- Insulated 8" deep removable ice bin with 1" recessed drain valve. Bin holds (3) standard 12" x 20" pans (not included).
- 5" Adjustable double-sided over shelf rack with pin system for better sturdiness and evenness
- Over shelf rack is removable
- Removable stainless steel cover with end bumpers to prevent scratching
- Includes hook to hold cover in back of the unit when not in use.
- Ergonomic handle
- (4) Lower corner bumpers
- Maneuvers easily on polyurethane casters, (2) rigid and (2) swivel with brakes.



SS-BC-2748-INSULIB-DTOS

Options:

- 18" folding shelf
- Heavy duty casters
- Single-sided overshelf

Benefits:

- Great for refrigerated items such as fruit, yogurt, and pastries.
- Insulated design keeps food cold
- Adjustable overshelf allows for conforming to needs and surroundings
- Sanitary and easy to clean
- Safely and efficiently transport product.



VENDING MERCHANDISER KIOSK - GRAB & GO CART



Vending Merchandiser Kiosk Grab & Go Cart w/ Double-Sided Canopy

Founded in 1946

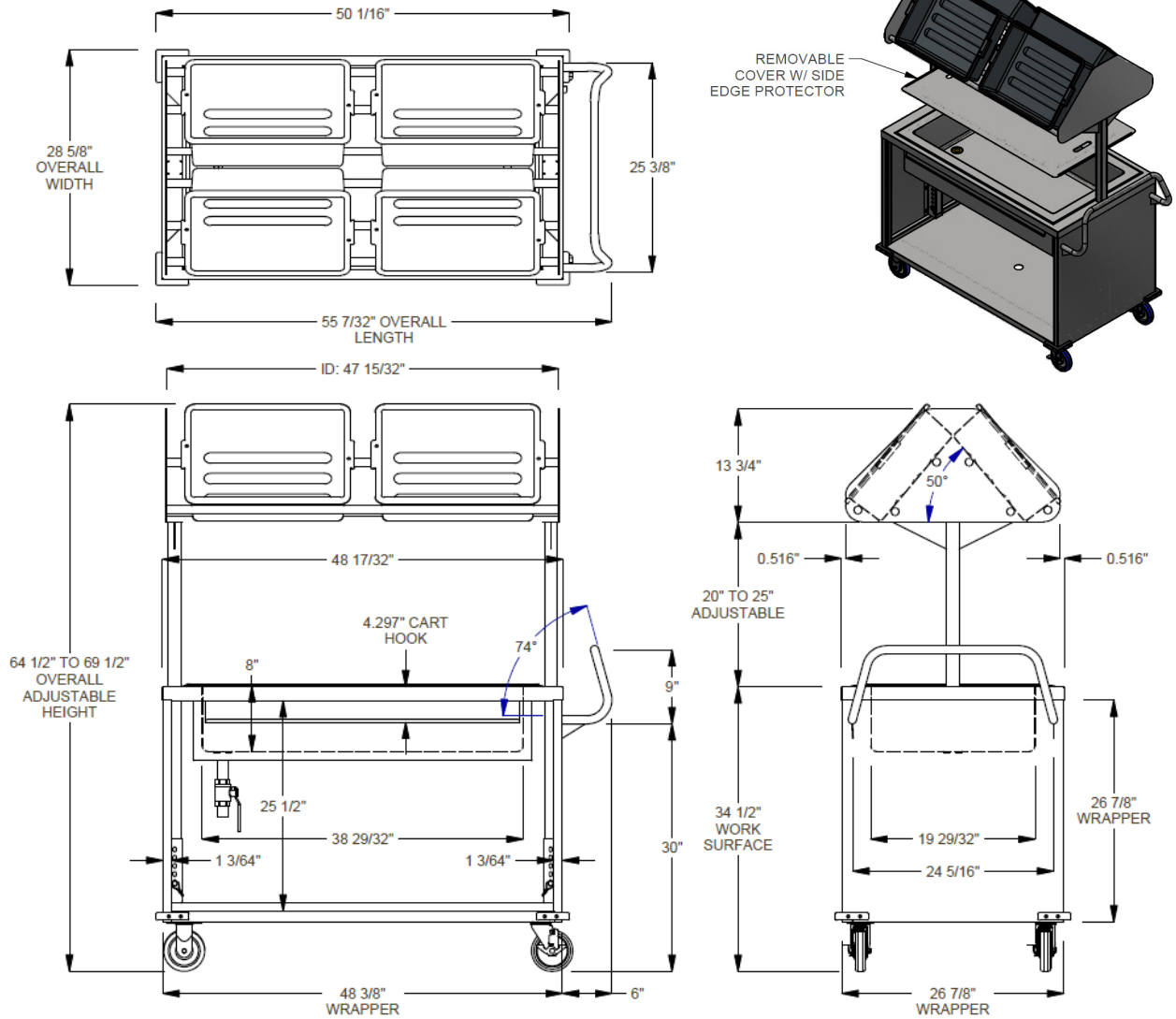

Model Number	Order#	Overall Dimensions			Approx. Ship Wt
		Width	Length	Adjustable Height	
		(in)	(in)	(in)	(lb)
SS-BC-2748-INSULIB-DTOS	1156680	28 3/5	55 1/5	64 1/2 - 69 1/2	228
Tub Dimensions					
WHPL-5K	-	15 1/2	20	5	-

Caster Information:

- (2) 5" Swivel Polyurethane Casters with Brakes
- (2) 5" Rigid Polyurethane Casters

Freight Class: 250



In line with our policy to continually improve our products, Winholt reserves the right to change materials and specifications without notice.