

 <b>REFRIGERATOR MANUFACTURER</b> <b>Turbo air</b> more durable, efficient, beautiful	4184 E. Conant St. Long Beach, CA 90808 Tel. 310-900-1000 Fax. 310-900-1077 <a href="http://www.turboairinc.com">www.turboairinc.com</a>	Project:	
		Model #:	
		Item #:	
		Available W/H:	Qty:
		Approval:	
		AIA #:	SIS #:
			CSI Section 11400

# Glass Half Door Heated Cabinet

*Reach-In  
PRO Series*

**Model : PRO-50-4H-G**

## ≡ FEATURES & BENEFITS ≡

- **Digital temperature control & monitor system**

  - Keeps food products safe by maintaining constant temperatures
  - Alarm beeps when doors are not sealed
  - Early warning alarm program detects issues before malfunction occurs
  - Digital display allows for easy monitoring
  - Sensitive touch display
  
- **Ducted fan air distribution system**

Maintains temperature within the food zone
  
- **On/Off switch**

ON/OFF switch is located on control panel
  
- **All stainless steel cabinet construction**

The PRO series model boasts a stainless steel interior and a **22 gauge** stainless steel exterior (galvanized steel top, bottom). It guarantees the utmost in cleanliness and long product life. The PRO series model adds a touch of style to the most refined setting.
  
- **Sturdy, clean stainless steel shelving**

Shelves are the most important part of cleanliness as they come in direct contact with food. After a while, PVC coated wire shelves may peel, rust and lead to unsanitary conditions. Only the Turbo Air PRO series uniquely provides stainless steel shelving.
  
- **LED interior lighting**

Includes a U.S. patented dimming option, exclusively from Turbo Air. This feature reduces energy consumption by 3~5%.
  
- **High-density polyurethane insulation**

The entire cabinet structure and solid doors are foamed-in-place using high density, CFC free polyurethane insulation.
  
- **Half length glass doors with locks**
  
- **Self-closing doors with stay open feature at 120 degrees**
  
- **Heated cabinet holds 140°F ~ 180°F for the best in food preservation**



Model	Swing Doors	CU./FT.	#of Shelves	Wattage (W)	AMPS	Crated Weight (lbs.)	L x D* x H† (inches)
<b>PRO-50-4H-G</b>	<b>4</b>	<b>49</b>	<b>6</b>	<b>3000</b>	<b>15</b>	<b>500</b>	<b>51<sup>3</sup>/<sub>4</sub> x 33<sup>7</sup>/<sub>8</sub> x 78</b>

Ver.20260205 Printed in U.S.A.

\* Depth does not include 1-1/4" for door handles. † Height does not include 5" for caster height.

# Glass Half Door Heated Cabinet

Reach-In  
PRO Series

## Model : PRO-50-4H-G

ELECTRICAL DATA	
Voltage	208~230V/115V/60Hz/1Ph
Plug Type	 NEMA L14-20P
Full Load Amperes	15
Wattage (W)	3000
Cord Length (ft.)	8
DIMENSIONAL DATA	
# of Doors	4
# of Racks Accepted	2
Net Capacity (cu. ft.)	49
Ext. Length Overall (in.)	51 <sup>3</sup> / <sub>4</sub> (1314mm)
Ext. Depth Overall (in.)*	33 <sup>7</sup> / <sub>8</sub> (860mm)
Ext. Height Overall (in.)†	78 (1982mm)
Int. Length Overall (in.)	42 <sup>1</sup> / <sub>4</sub> (1073mm)
Int. Depth Overall (in.)	27 <sup>5</sup> / <sub>8</sub> (702mm)
Int. Height Overall (in.)	58 <sup>3</sup> / <sub>4</sub> (1493mm)
# of Shelves	6
Shelf Size (L x D) (in.)	23 <sup>3</sup> / <sub>4</sub> x 26 <sup>3</sup> / <sub>8</sub>
Net Weight (lbs.)	442
Gross Weight (lbs.)	500

Design and specifications subject to change without notice.

Actual shipping weight may differ due to extra packing materials for product protection.

\* Depth does not include 1-1/4" for door handles.

† Height does not include 5" for caster height.

### ■ WARRANTY : 3 Year Parts and Labor Warranty

### ■ STANDARD FEATURES

- Door locks
- 4" dia. swivel casters with locks on the front set
- Easy replaceable one piece magnetic door gaskets
- Solid and sturdy grille design

### ■ OPTIONAL ACCESSORIES

- 2.5" caster, 1/2" diameter & 13 TPI: 30265H0100 (non-brake), 30265H0200 (w/ brake)
- 5" caster, 1/2" diameter & 13 TPI: M726500100 (non-brake), M726500200 (w/ brake)
- 4.7" leveling seismic leg (1/2", 13 TPI): 30221M0500
- 6" stainless steel leg: 30221M0600
- Additional stainless steel shelf: (L, R) H50R901700
- Tray slides kits: TS23-N1LR(#1), TS23-N1LR HALF, TS23-N4LR(#4), TS23-N4LR HALF, TS23-UNLR-H(Universal), TS23-UNLR-H HALF

## PLAN VIEW

(unit : inch)

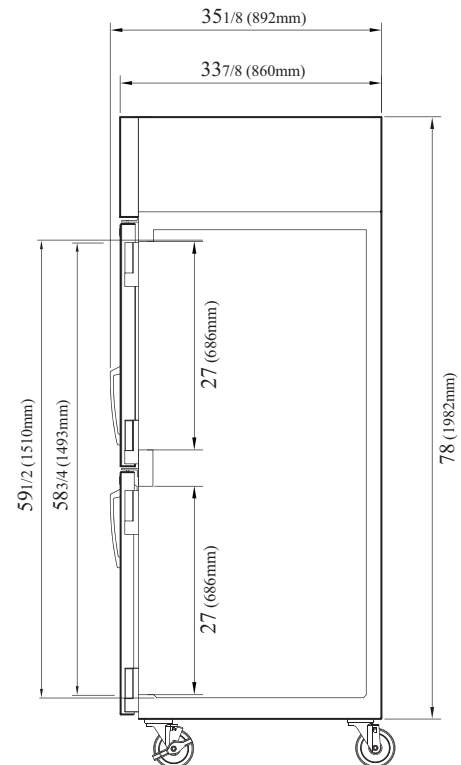
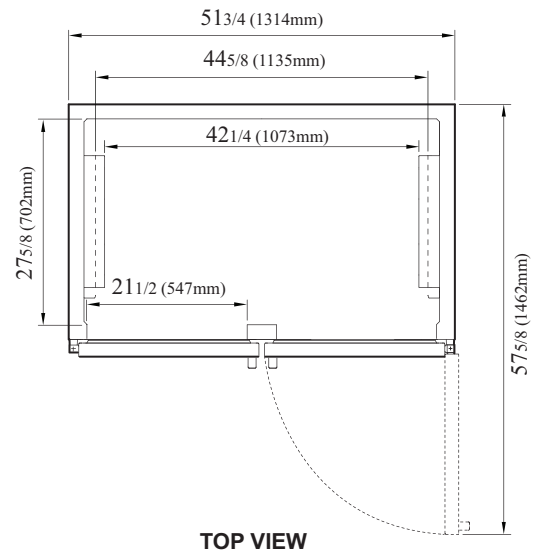

Ver.20260205



ENERGY STAR®  
Qualified

- Turbo Air: 800-627-0032
- Bake Tech Innovation: 800-500-3519
- Warranty: 800-381-7770
- AC: 888-900-1002