



Project _____

AIA # _____ SIS # _____

Item # _____ Quantity _____ C.S.I. Section 114000

R Series

Roll-Thru Heated Cabinet Model
66" High Rack, 32" Deep



STANDARD PRODUCT FEATURES

- Stainless Steel Exterior & Interior
- Traulsen's Smart Control™ with LED Display
- Ducted Fan Air Distribution System
- Standard Operation Temperature Range 140 to 180°F
- ON/OFF Switch Located on Control Face
- Full-Height Stainless Steel Doors with Locks
- Self-Closing Doors with Stay Open Feature
- Standard Door Hinging F & R: 232LP = Left/Right (other hings available)
- Automatically Activated LED Lights
- Stainless Steel Breaker Caps
- Accommodates Roll-In Racks Up to 66" High (provided by others)
- Magnetic Snap-In EZ-Clean™ Door Gasket
- Stainless Steel Door Liners
- Stainless Steel Interior Rack Guides
- Stainless Steel Threshold Ramps
- Stainless Steel One-Piece Louver Assembly - Front & Rear

ACCESSORIES & OPTIONS

- SmartConnect™ Monitoring App with Wi-Fi Connectivity
- Coated Wire Shelf Package (includes 3 shelves per section)
- Additional Coated Wire Shelves for Above
- Rehinging Feature (consult factory)
- Stainless Steel Shelf Package (includes 3 shelves per section)
- Additional Stainless Steel Shelves for Above
- Locking Hasps (padlocks supplied by others)
- Optional 208-230/60/1 Voltage
- Kool Klad™ Exterior Laminate Decor
- Clear Glass Doors in Place of One or More Solid Doors
- Fluorescent Lights
- Stainless Steel Banking Strips
- Transition Strip for Recessed Floor Installation
- Prison/Correctional Facility Options

- GUARANTEED FOR LIFE CAM-LIFT HINGES
- GUARANTEED FOR LIFE HORIZONTAL WORKFLOW DOOR HANDLES



Models listed to the applicable UL, CSA and NSF standards by an approved NRTL. Consult the factory or unit data plate for additional information.

AVAILABLE CONFIGURATIONS

R Series Models
RIH232LP-FHS

Doors
Full Height Solid

Approved by _____ Date _____ Approved by _____ Date _____

MODEL:

RIH232LP-FHS

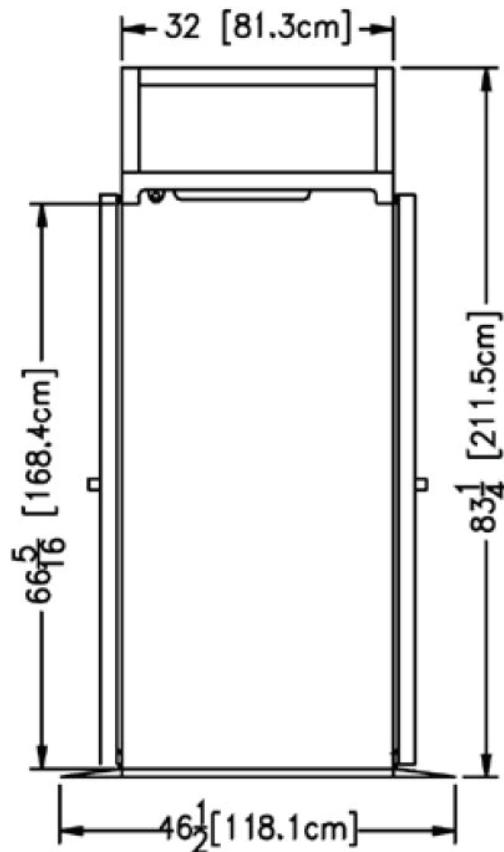
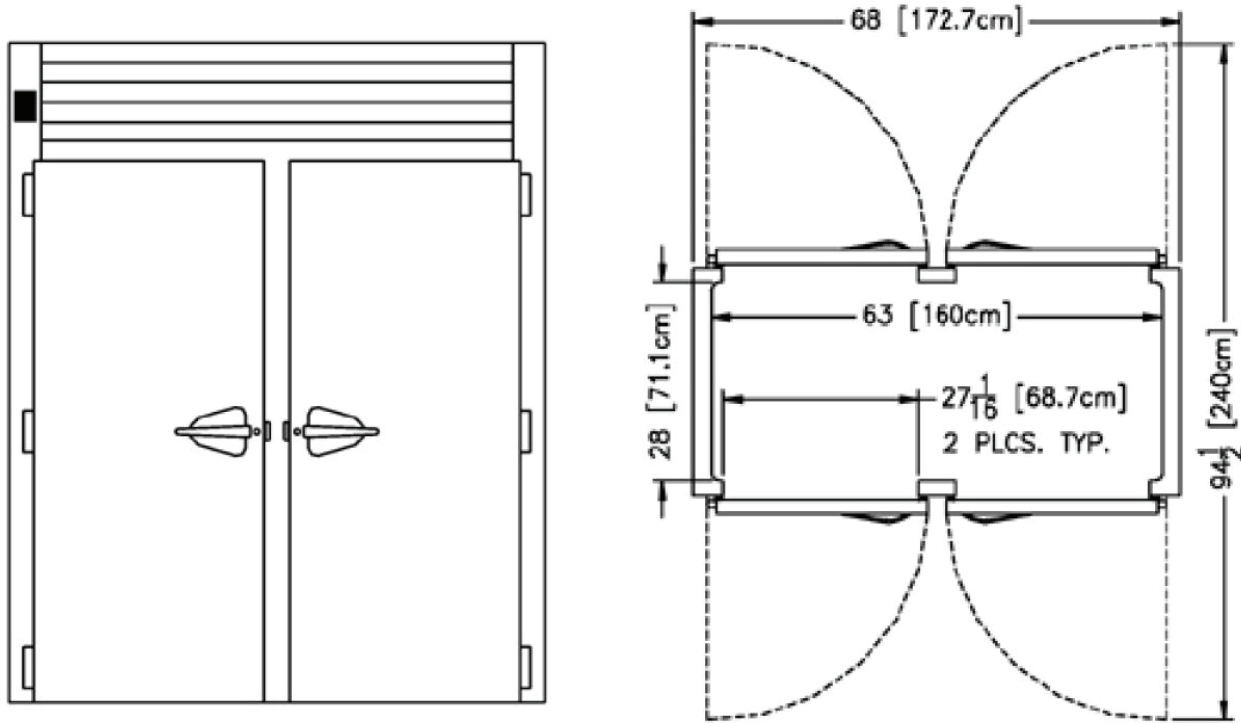

➤ CAD and/or Revit Files Available

<https://traulsen.klccad.com/>



MODEL:

RIH232LP-FHS

MODEL	RIH232LP-FHS
DIMENSIONAL DATA	
Net capacity cu. ft.	78.84 (2232.5 cu l)
Length - overall in.	68" (172.7 cm)
Depth - overall in.	46 1/2" (118.1 cm)
Depth - over body in.	32" (81.3 cm)
Depth - door open 90° in.	94 1/2" (240 cm)
Clear door width in. ¹	27 1/16" (68.7 cm)
Clear door height in.	66 5/16" (168.4 cm)
Height - overall in.	83 1/4" (211.5 cm)
Capacity - 66" High	2
ELECTRICAL DATA	
Voltage Plug	208-230/115/60/1 Hard Wired
Feed wires with Ground	4
Heater Wattage Full Load Amperes	@208V = 3000 15.5 @230V = 3672 17.1 @240V = 4000 17.7
SHIPPING DATA	
Length - Crated in.	72" (182.9 cm)
Width - Crated in.	42" (106.7 cm)
Height - Crated in.	94" (238.8 cm)
Volume - Crated cu. ft.	164.5 (4658.1 cu l)
Weight - Crated lbs.	843 (382.4 kg)

NOTES: Figures in parentheses reflect metric equivalents.

1. Please note that the available cabinet width narrows for 6" from the top of the door frame to 25 7/8" in order to allow for the heater fans.
2. Heater is capable of operation from 208V to 230V as supplied standard. Actual amp figure will change at any voltage other than 208V.
3. Traulsen does not offer or recommend a NEMA L14-20 plug for any 2 or 3-section hot food cabinet. We can offer a NEMA L14-30P plug through SPD as a special.

EQUIPMENT SPECIFICATIONS

CONSTRUCTION, HARDWARE, INSULATION

The interior is made from stainless steel and the cabinet exterior front, one piece sides, louver assembly, doors and door liners are constructed of heavy gauge stainless steel. The interior floor and exterior bottom are constructed of stainless steel & insulated with 3/4" of resilient cork. A readily attachable stainless steel ramps are provided.

Door is equipped with heavy-duty, extruded wiper gasket for sealing to bottom ramp, removable plug cylinder locks & guaranteed for life gravity action, self-closing metal, cam-lift hinges with a stay open feature. Hinges include a concealed switch to automatically activate the interior LED lighting. Guaranteed for life, workflow door handles are mounted horizontally over recess in door which limits protrusion from door face into aisleways. Door has seamless, polished metal corners.

Gasket profile & EZ-Clean™ material simplify cleaning & increase overall gasket life. Both the cabinet & door are insulated with an average of 2" thick high density, non-CFC, foamed in place polyurethane.

HEATING SYSTEM

A low watt density, serpentine style, heater is employed for the generation of electric heat. Low velocity air is forced across its large surface area to efficiently move heat radiating away from these through a down-air distribution duct, where it is then evenly distributed throughout the cabinet, assuring the proper holding environment for hot food product, without drying. A vent, located at the top of the cabinet, is included for positive humidity control.

CONTROL

Traulsen's Smart Control™ features advanced control algorithms & sophisticated diagnostic capabilities to optimize performance. Utilizing smart sensors, it adapts the operation of the heating system to a variety of environments & usage patterns. The Smart Control™ also offers a complete set of visual alarms designed to alert the user to critical events such as power outages or a prolonged door opening. In the event of an alarm, a dedicated Alarm LED will illuminate, informing the user of the critical event and duration.

INTERIOR

Readily removable, interior-mounted, stainless steel guides for racks are provided for protection. Maximum rack size with wheels inboard of frame is 27" wide by 29" deep by 66" high. Racks are supplied by others.

WARRANTY

A six year parts and labor warranty is provided standard.