



PROJECT NAME		LOCATION		AIA #
ITEM #	QTY	MODEL #		SIS #

SPEC SERIES®

PASS-THRU SOLID HALF FRONT/SOLID HALF REAR SWING DOORS HEATED CABINETS

models	STR1HPT-2HS-2HS	STA1HPT-2HS-2HS	STG1HPT-2HS-2HS
--------	-----------------	-----------------	-----------------



STR1HPT-2HS-2HS	
Exterior	Stainless steel door, front & sides.
Interior	Stainless steel side walls, back, floor, door liner, & ceiling.
Shelving	(1) Interior kit option included per full section.

STA1HPT-2HS-2HS	
Exterior	Stainless steel door, front & sides.
Interior	Aluminum side walls & back. Stainless steel floor & ceiling.
Shelving	(3) Heavy duty, chrome plated, wire shelves per section.

STG1HPT-2HS-2HS	
Exterior	Stainless steel door, with matching aluminum sides.
Interior	Aluminum side walls & back. Stainless steel floor & ceiling.
Shelving	(3) Heavy duty, chrome plated, wire shelves per section.

plan view

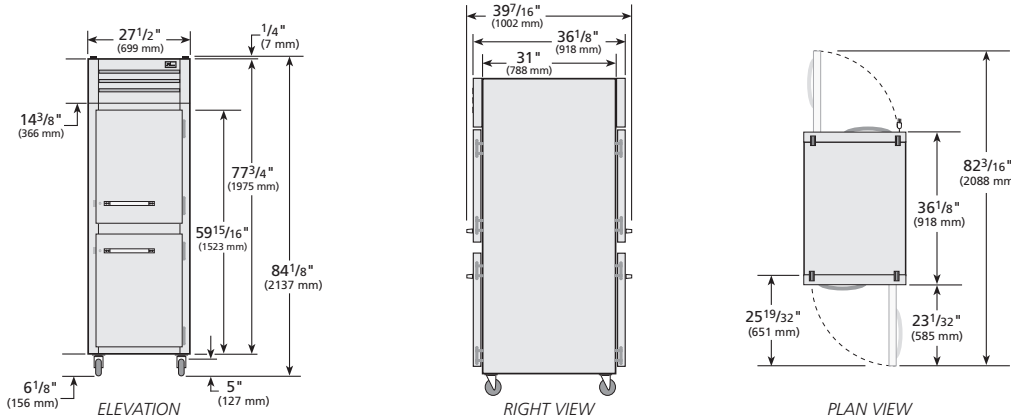

SPECIFICATIONS

Dimensions	in.	mm.
Length	27 1/2	699
Depth †	36 1/8	918
Height *	77 3/4	1975
Electrical	U.S.	International
Watts	1500	
Voltage	208-240/60/1	
NEMA	6-15P	
Cord Length	9 ft.	2.74 M.

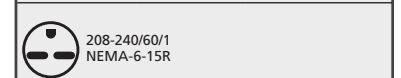

* Height does not include 6 1/8" (156 mm) for castors or 6" (153 mm) for optional legs. Height does not include 1/4" (7mm) for system mechanical components.
 † Depth does not include 1 1/2" for front & back door handles.

Specifications subject to change without notice.
 Chart dimensions are rounded up to the nearest 1/8" (millimeters rounded up to the next whole number).

MADE WITH INNOVATION IN THE USA
 UL US
 2/26 Printed in U.S.A.

APPROVALS

AVAILABLE AT



PROJECT NAME	LOCATION	AIA #
ITEM #	QTY	MODEL #
		SIS #

SPEC SERIES®

PASS-THRU SOLID FRONT/SOLID REAR SWING DOORS HEATED CABINETS

models	STR1HPT-2HS-2HS	STA1HPT-2HS-2HS	STG1HPT-2HS-2HS
--------	-----------------	-----------------	-----------------



standard features

HEATER SYSTEM

- Cabinet designed to provide holding temperatures of 140°F to 180°F (60°C to 82.2°C). Heating system controlled by exterior on/off switch and electronic temperature control.
- One (1) stainless steel (for corrosion resistance), heating element for uniform generation of electric heat. Cabinet comes with a total of 1500 watts.
- Manually controlled vent located on top of the cabinet for positive humidity control.

CABINET CONSTRUCTION

- Insulation - Entire cabinet structure and solid door are foamed-in-place using a high density, polyurethane insulation that has zero ozone depletion potential (ODP) and zero global warming potential (GWP).
- 5" (127 mm) diameter plate castors - locks provided on front set.

DOORS

- Lifetime guaranteed bolt style door lock standard.
- Lifetime guaranteed heavy duty all metal working door handles.
- Positive seal self-closing doors with 120° stay open feature. Lifetime guaranteed external cam lift door hinges, four (4) per door section.

- Magnetic door gaskets of one piece construction, removable without tools for ease of cleaning.

LIGHTING

- Incandescent interior lighting; lights activated by exterior on/off switch, safety shielded.

MODEL FEATURES

- Exterior digital temperature display, available with either °F or °C.
- Designed to hold warm baked or cooked food. Cabinet is not designed to heat ambient or cold product.
- NSF-4 compliant for open food product.

ELECTRICAL

- True requires that a sole use circuit be dedicated for the unit.
- Unit completely pre-wired at factory and ready for final connection to a 208-240/60/1 Hz. single phase, 15 amp dedicated outlet. Cord and plug set included.

OPTIONAL FEATURES/ ACCESSORIES

(upcharge & lead times may apply)

- 6" (153 mm) standard legs.
- 6" (153 mm) seismic/flanged legs.
- 6" (153 mm) stainless steel legs.
- Additional shelves.
- Security package.
- Field reversible hinge.

SHELVING KIT OPTIONS

- STR series kits factory installed at no charge. STA & STG series kits field installed, upcharge applies, lead times may apply.
- Kit #1: Nine (9) sets of #1 type tray slides and pilasters (field installed), bottom support of one (1) 18"L x 26"D (458 mm x 661 mm) pan or two (2) 14"L x 18"D (356 mm x 458 mm) pans.
- Kit #2: One (1) set half-section #2 steel rod tray slides and pilasters (field installed), rim support of one (1) 18"L x 26"D (458 mm x 661 mm) pan.
- Kit #3: Six (6) sets of universal type tray slides and pilasters (field installed), bottom support of one (1) 18"L x 26"D (458 mm x 661 mm) pan, two (2) 14"L x 18"D (356 mm x 458 mm) pans or two (2) 12"L x 20"D (305 mm x 508 mm) pans.
- Kit #4: Three (3) chrome shelves 25"L x 27 3/4"D (635 mm x 705 mm). Four (4) shelf supports included per shelf (field installed); adjustable on 6" (153 mm) increments. Optional wall mounted shelf support pilasters (field installed) with four (4) shelf clips per shelf available; adjustable on 1/2" (13 mm) increments (must order at time of cabinet order).
- Additional kit option components available individually.

METRIC DIMENSIONS ROUNDED UP TO THE NEAREST WHOLE MILLIMETER
 SPECIFICATIONS SUBJECT TO CHANGE WITHOUT NOTICE



Model	Elevation	Right	Plan	3D	Back
ST()1HPT-2HS-2HS					