

"UBDB-18" UNDERBAR DRAINBOARDS

Slim-Line, 18" Width

FEATURES:

- 18GA Stainless Steel Construction
- Type 300 Stainless Steel With #4 Polish, Satin Finish
- Standard Pre-Drilled Holes On Sides For Attaching Adjacent Units Together
- Slim Line 18" Deep Front To Back
- Creased Deck For Improved Drainage
- Removable Perforated Drainboard Insert For Increased Air Circulation.
- Standard Front Inserts For Speed Rail Attachment
- Stainless Steel Front To Back Bracing

SPECIFICATIONS:

- Top: 18GA Type 300 Stainless Steel
- Front Apron: 18GA Type 300 Stainless Steel
- Backsplash: 18GA Type 300 Stainless Steel
- Sides: 18GA Type 300 Stainless Steel
- Bolt On 1-5/8" Stainless Steel Legs For Fast Installation
- 1-1/4" Front To Back Bracing
- 1" Adjustable Stainless Steel Bullet Feet
- Z-Clip To Mount To Wall
- Bolt To Adjacent Underbar Piece
- Mounting Options Allow For Flexible Installation
- Options To Remove Back Or Front And Back Legs For A Clean Installation
- 1-3/8" Drain
- 1" MPT 1-1/2" Long Drain Connection



UBDB-1824

CERTIFICATIONS:



ACCESSORIES

MODEL	DESCRIPTION
UBSS-21-L	Slim-Line, Left Hand Side Splash
UBSS-21-R	Slim-Line, Right Hand Side Splash
UBSR1-12	12" Single Speed Rail
UBSR1-18	18" Single Speed Rail
UBSR1-24	24" Single Speed Rail
UBSR1-30	30" Single Speed Rail
UBSR1-36	36" Single Speed Rail
UBSR2-12	12" Double Speed Rail
UBSR2-18	18" Double Speed Rail
UBSR2-24	24" Double Speed Rail
UBSR2-30	30" Double Speed Rail
UBSR2-36	36" Double Speed Rail

"UBDB-18" UNDERBAR DRAINBOARDS

MODEL	SIZE (LXWXH)	LENGTH (L)	WEIGHT (LBS)
UBDB-1812	12"x18"x32-1/2"	12"	31
UBDB-1818	18"x18"x32-1/2"	18"	36
UBDB-1824	24"x18"x32-1/2"	24"	41
UBDB-1830	30"x18"x32-1/2"	30"	46
UBDB-1836	36"x18"x32-1/2"	36"	51

ALL DIMENSIONS ARE TYPICAL. TOLERANCE +/- .500". JOHN BOOS & CO. RESERVES THE RIGHT TO CHANGE SPECIFICATIONS WITHOUT NOTICE.

DETAILED SPECIFICATIONS

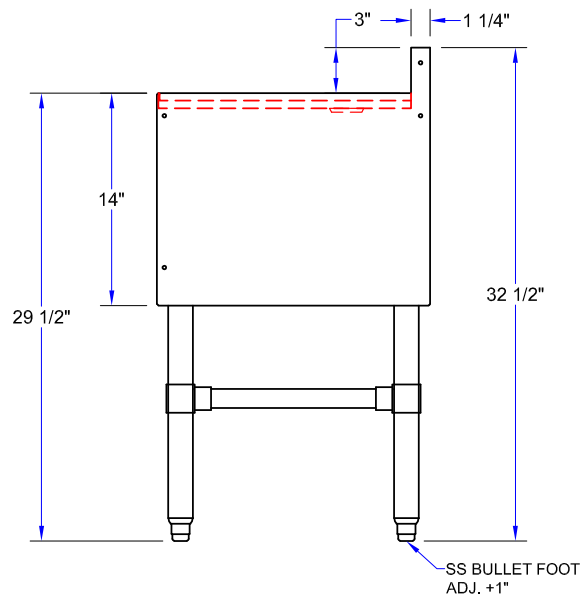
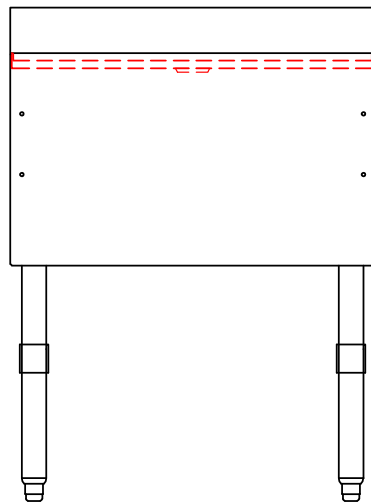
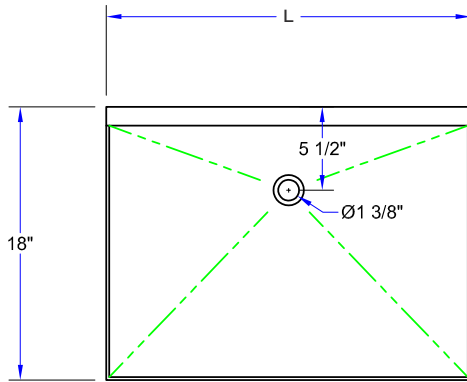

"UBDB-18" UNDERBAR DRAINBOARDS

MODEL	SIZE (LXWXH)	LENGTH (L)	WEIGHT (LBS)
UBDB-1812	12"x18"x32-1/2"	12"	31
UBDB-1818	18"x18"x32-1/2"	18"	36
UBDB-1824	24"x18"x32-1/2"	24"	41
UBDB-1830	30"x18"x32-1/2"	30"	46
UBDB-1836	36"x18"x32-1/2"	36"	51

ALL DIMENSIONS ARE TYPICAL. TOLERANCE +/- .500". JOHN BOOS & CO. RESERVES THE RIGHT TO CHANGE SPECIFICATIONS WITHOUT NOTICE.