

STANDARD FEATURES

- **Advanced 4.3" TFT Display** Intuitive condition alerts with multi-lingual, user-friendly operational guidance
- **Enhanced Visual On-Board Diagnostics** Quickly identify machine faults for rapid resolution and less downtime
- **Varicycle** Allows user to extend wash time up to 16 minutes for maximum cleaning of heavily soiled wares
- **ENERGY STAR[®] Certified**
- 60 Racks Per Hour
- Racks (Peg & Flat)
- 0.76 Gallons Per Rack
- Automatic Delime Function
- **Automatic Drain Valve** Heavy duty, gear driven, full port ball valve, stainless and brass construction
- **Rinse Sentry**
Automatically extends wash cycle until booster reaches optimal sanitization temperature before final rinse begins
- **Auto Start**
Machine automatically starts when the door is closed
- **Field Convertible Electric** Ability to convert from three phase to single phase power, 208 or 240 Volt compatible
- **Standard Single Point Connection**
- **Vent Fan, Detergent, Rinse Aid Signal Provided**
- **Flexible Configuration Options** Can be field configured for corner or straight through operation
- **Low Water Tank Heat Protection**
- **Factory Authorized Startup**

OPTIONS AND ACCESSORIES

- Drain water tempering kit (mounted)
- Corner operation splash baffle
- Champion ION scale prevention system
- Built-in booster configured to ensure 180° rinse
- Water hammer kit (unmounted)
- Pumped drain

DH3000



Rendered image is for general visual representation only. Please refer to specifications for the latest detailed product information.

SPECIFIER STATEMENT

Specified unit will be Champion Model DH3000 High Temperature Door-Type dishwashing machine.

Features top mounted splash proof controls, user intuitive 4.3" color display, Varicycle extendable wash timer, rinse sentry, autostart, automatic drain, automatic delime function, and on-board diagnostics. Machine can also be field or factory converted to display French/English and Fahrenheit/Celsius.

1 year parts and labor warranty.

DH3000

3000 Series

Champion®

The Dishwashing Machine Specialists

Warning:

Plumbing and electrical connections should be made by qualified personnel who will observe all the applicable plumbing, sanitary, and safety codes and the National Electrical Code.

Note:

Water Hammer Arrestor (meeting ASSE-1010 standard or equivalent) to be supplied (by others) in common water supply line at service connection. Recommended water hardness to be 3 grains or less for optimal performance results.

Optional Drain Tempering:

1/2" NPT cold water connection required. 1/2" NPT drain connection from back flow preventer to house drain. (FIELD INSTALLED and PLUMBED).

UTILITIES

1 Electrical Connections

See Machine Electrical Specs

2 Hot Water

3/4" NPT Hot Water 110°F – 140°F
45 PSI Dynamic Minimum Incoming
Final Rinse Operates at 20 PSI

3 Drain

1" NPT - 15 GPM Max Flow

4 Drain Water Tempering (Optional)

1/2" NPT Cold Water
25 PSI Dynamic Minimum Incoming

SPECIFICATIONS

Capacity

Racks per hr (NSF rated)..... 60
Wash tank (US gal.) 9.5

Motor Horsepower

1HP

Water Consumption

US Gal. per rack 0.76

Temperature

Wash (°F)..... 150
Rinse (°F)..... 180

Heating

Tank heat, electric (kW)..... 5.2
Electric booster (kW)..... 7.5

Time cycles in minutes

Wash cycle time	1	
Varicycle extended wash		Up to 16

Time cycles in seconds

Wash	35	Up to 960
Dwell	1	1
Rinse	7	7
Sanitary Dwell	17	17
Total	60	Up to 985

Machine and Built-in Booster (Standard)

Electrical Rating	Booster	Rated Amps	Minimum Supply Circuit Ampacity	Maximum Overcurrent Protective Device
208/60/1	7.5kW	65 A	80	80
240/60/1	10.0kW	75 A	80	80
208/60/3	7.5kW	40 A	50	50
240/60/3	10.0kW	45 A	50	50

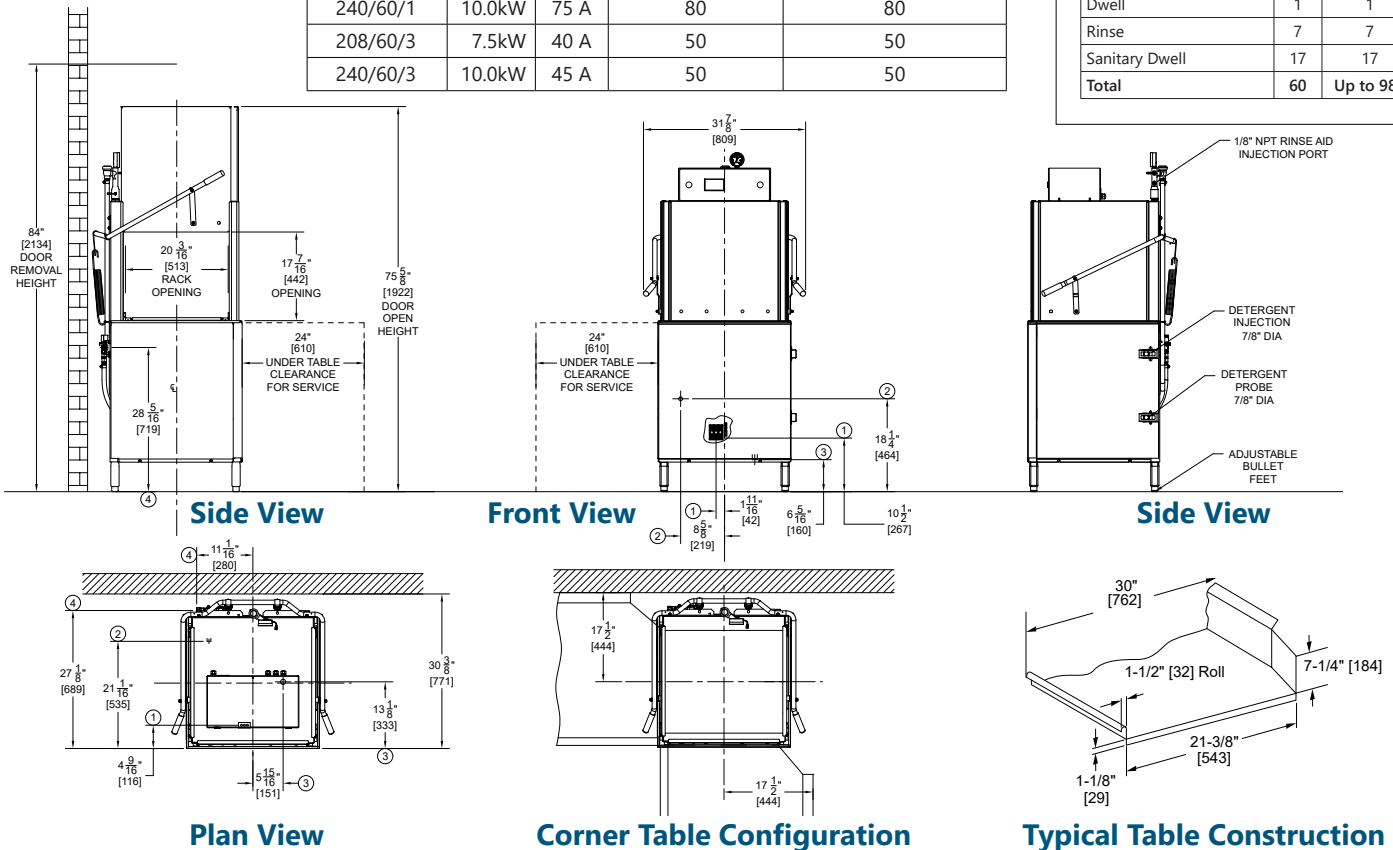

Champion Industries | 3765 Champion Blvd, Winston-Salem, NC 27105 | Tel: (800) 532-8591 Fax: (336) 661-1979
www.championindustries.com

Due to an ongoing value analysis program at Champion, specifications contained in this catalog are subject to change without notice.

2/25