

Job: _____

Item: _____

Quantity: _____

“U” Type Nesting Racks

Virtually maintenance free

- All welded construction ensures the maximum strength and stability of each rack.
- Shipped assembled for immediate use.
- Supporting cross braces have gussets securely welded into place to prevent “racking”.

“Worry Free” Handling

- Specially designed to support trays by the bottom, not just the lip, ensuring equal load distribution for easy, “worry-free” handling.
- Heavy duty aluminum tube and angle slides maximize strength and durability.

Easy to Maneuver

- Equipped with four 5” heavy duty platform type casters, these all welded aluminum carts are built to be pushed around.
- Non-marking wheels protect floors and minimize noise.

Sanitary

- All seams are fully welded and sealed providing a smooth, easy to clean surface.
- No cracks or crevices to trap dirt!

Guaranteed To Last

- Five-Year Guarantee against material defects and workmanship.
- Lifetime Guarantee against rust and corrosion.



#1330U

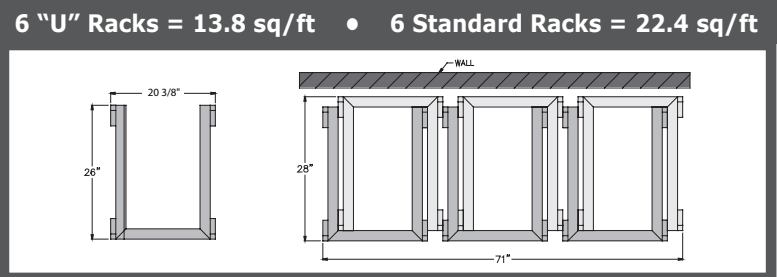

This information is for general sales and engineering use only. New Age Industrial reserves the right to modify or make changes at any time without notice to materials and specifications.

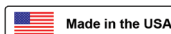

Distributed by:

Job: _____

Item: _____

Quantity: _____

“U” Type Nesting Racks

MATERIAL: Hi-tensile, corrosion resistant, rust proof, primary extruded aluminum, Type 6463-T5 alloy.

CONSTRUCTION: All heli-arc welded with all seams welded and sealed (no rivets).

SIDES: Each side had two vertical posts of 1" x 1" x .070" wall tube. Welded to each side are angle runners of 1¼" x 1½" x .100" wall aluminum angle, spaced on 2" or 3" centers.

HORIZONTAL “Z” SUPPORTS: Three 1" x 2" tubes, welded into a “U” shaped unit.

CORNER GUSSETS: Gussets of 1½" x 1½" x 5/8" thick angle are welded to the inside angles (bottom side) where horizontal cross bracing meets vertical uprights.

Note: Each gusset requires 4-½" of weld.

BASE: A “U” support frame with pre-tapped caster plates welded to each corner.

CASTERS: Platform type, 5" diameter wheel, full swivel design with sealed ball bearing axle. Wheel material is non-marking polyurethane.

NSF Certified.

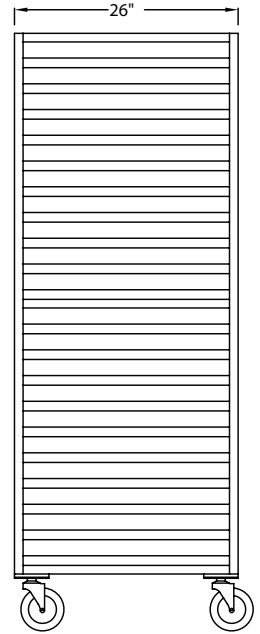
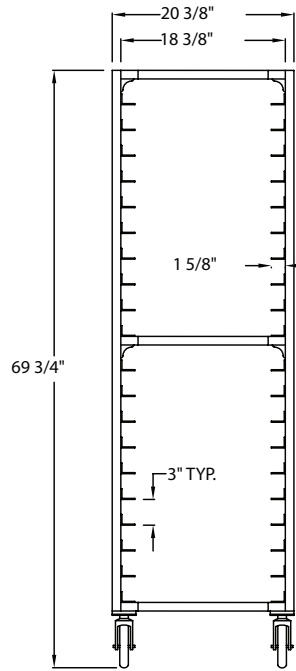
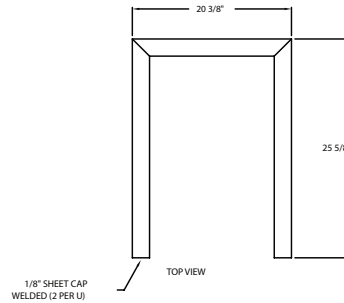

Model No.	Size W-H-D	Pan Cap.	Runner Spacing	Ship Wt
1331U	20¾" x 69¾" x 26"	20	3"	70#
1330U	20¾" x 69¾" x 26"	30	2"	84#

Four 5" platform type casters (#C450).
 Designed to accommodate 13" x 18", 14" x 18" and 18" x 26" pans.

OPTIONS:

- Caster Locks (2)** -- Add "CL(B)" suffix to model #.
- Medical Casters (4)** -- Add "MD" suffix to model #.
- Vertical Bumpers (4)** -- Add "VB" suffix to model #.

This information is for general sales and engineering use only. New Age Industrial reserves the right to modify or make changes at any time without notice to materials and specifications.



Distributed by: